

ARTISAN®

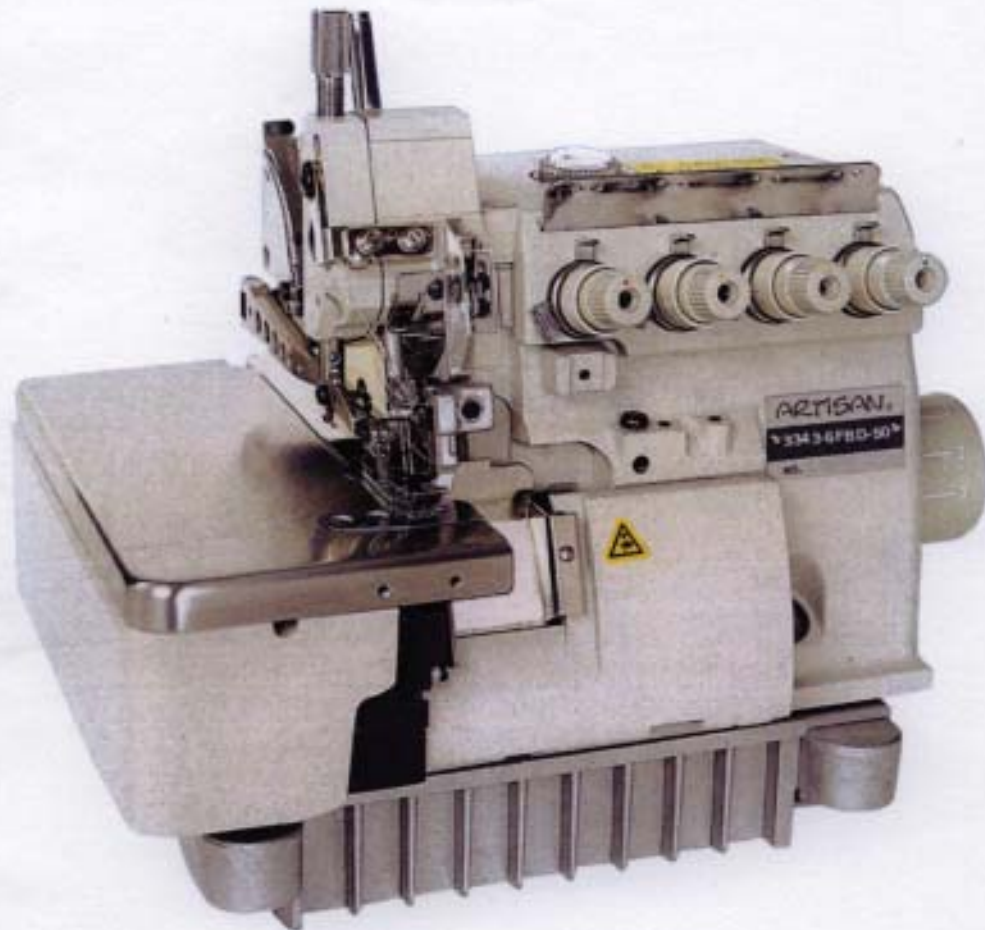

MODEL **3343**

Serger and Sew Overlock Sewing Machine

**Operators Manual
and
Spare Parts List**

重要安全事项
IMPORTANT SAFETY INSTRUCTIONS

此缝纫机在有的国家（设置场所）由于该国的安全规定而被禁止使用。同时，技术服务也同样被禁止。

Putting sewing systems into operation is prohibited until it has been ascertained that the sewing systems in which these sewing machines will be built into, have conformed with the safety regulations in your country. Technical service for those sewing systems is also prohibited.

1. 使用此缝纫机时，必须遵守包括如下项目的基本安全措施。
1. Observe the basic safety measures, including, but not limited to the following ones, whenever you use the machine.
2. 使用此缝纫机之前，请阅读本使用说明书在内的所有指示文件。同时应将此使用说明书妥善保管，以便能够随时查阅。
2. Read all the instructions, including, but not limited to this instruction Manual before you use the machine. In addition, keep this instruction Manual so that you may read it at anytime when necessary.
3. 此缝纫机应与贵国的有关安全规定一起使用。
3. Use the machine after it has been ascertained that it conforms with safety rules/standards valid in your country.
4. 使用此缝纫机和缝纫机动作中，所有的安全装置应安装到规定的位置。没有安装规定的安全装置的缝纫机禁止使用。
4. All safety devices must be in position when the machine is ready for work or in operation. The operation without the specified safety devices is not allowed.
5. 此缝纫机应由接受过培训的操作人员来操作。
5. This machine shall be operated by appropriately-trained operators.
6. 使用缝纫机时，建议戴安全防护眼镜。
6. For your personal protection, we recommend that you wear safety glasses.
7. 发生下列情况时，应立即关掉电源开关，或拔下电源线插头。
7. For the following, turn off the power switch or disconnect the power plug of the machine from the receptacle.
 - 7-1 机针、弯针、分离器等穿线和更换旋梭时。
7-1 For threading needle(s), looper, spreader etc. and replacing bobbin.
 - 7-2 更换机针、压脚、针板、弯针、分离器、送布牙、护针器、支架、布导向器等时。
7-2 For replacing part(s) of needle, presser foot, throat plate, looper, spreader, feed dog, needle guard, folder, cloth guide etc.
 - 7-3 修理时。
7-3 For repair work.
 - 7-4 工作场所无人了或离开工作场所时。
7-4 When leaving the working place or when the working place is unattended.
 - 7-5 使用离合马达时，请等待马达完全停止之后再行。
7-5 When using clutch motors without applying brake, it has to be waited until the motor stopped totally.
8. 缝纫机以及附属装置使用的机油、润滑脂等液体流入眼睛或沾到皮肤上时，或被误饮时，应立即清洗有关部份并去医院治疗。
8. If you should allow oil, grease, etc. used with the machine and devices to come in contact with your eyes or skin or swallow any of such liquid by mistake, immediately wash the contacted areas and consult a medical doctor.

为了安全地使用缝纫机的注意事项

FOR SAFE OPERATION



1. 为了防止触电事故，请不要在接通电源的状态下打开马达电气箱的盖子或触摸电气箱内的零件。
1. So as to avoid electric shock hazards, do not open the cover of the electrical box of the motor or touch any part inside the electrical box with the power to the machine turned NO.



1. 为了防止人身事故的发生，请不要在卸了皮带护罩、眼睛防护罩等安全装置的状态下运转缝纫机。
1. To prevent possible personal injury, never operate the machine with the belt cover and the eye guard removed.
2. 为了防止被卷入的人身事故的发生，请使用带马达皮带轮护罩的马达。
2. To protect against possible personal injury resulting from being caught in the motor, use a motor that is provided with a motor pulley cover.
3. 为了防止触电事故的发生，请不要卸下电源地线的状态下运转缝纫机。
3. To avoid electric shock hazards, never operate the machine with the ground wire for the power supply removed.
4. 为了防止被卷入的人身事故的发生，缝纫机运转途中请不要将手指、头发、衣服靠近皮带轮、V形皮带、马达，也不要把手指放到上面。
4. During operation, be careful not to allow your or any other person's head, hands or fingers to come close to the handwheel, V belt and motor so as to prevent possible personal injury that may occur when your hands/fingers are caught in the machine. Also, do not place anything close to them.
5. 为了防止人身事故的发生，打开电源后或缝纫机运转中请不要把手指放到切布刀和机针的附近。缝纫机运转中请不要把手指放到眼睛防护罩内。
5. So as to avoid possible injury to your hands and fingers, do not put any of them near the cloth cutting knife and the needle when turning the power to the machine or while the machine is in operation.
6. 为了防止人身事故的发生，缝纫机运转中请不要把手指放到眼睛防护罩内。
6. To prevent possible injury to your hands and fingers, do not put any of them inside the eye guard while the machine is in operation.
7. 为了防止触电、漏电、火灾事故，拔插电源线前一定先关掉缝纫机电源，手持电源插头进行插拔。
7. To avoid electric shock hazards and accidents arising from damaged electrical components, be sure to turn OFF the power switch before inserting/detaching the power plug.
8. 为了防止突然启动造成人身事故，离开缝纫机时请一定关掉电源。
8. So as to protect against possible personal injury resulting from abrupt start of the machine, make sure to turn OFF the power to the machine when you leave your machine.
9. 为了防止突然启动造成人身事故，发生停电后一定关上电源。
9. In the event of a power failure, be sure to turn OFF the power to the machine to protect against possible personal injury resulting from abrupt start of the machine.
10. 为了防止突然启动造成人身事故，拆卸皮带防护罩、马达皮带轮防护罩以及V形皮带时，请一定关掉电源，用脚踏踏板确认不动后再拆卸。
10. So as to protect against possible personal injury resulting from abrupt start of the machine, remove the belt cover, motor pulley cover and the V belt after turning OFF the power to the machine and confirming that the sewing machine will not run even by depressing the start pedal.
11. 为了防止突然启动造成人身事故，检修、调整、扫除、穿线、换针时，请一定先关掉电源，用脚踏踏板确认不动后再进行。
11. Before inspecting, adjusting or cleaning the machine, threading the machine head or replacing the needle, so as to protect against possible personal injury resulting from abrupt start of the machine, be sure to turn OFF the power to the machine so as to prevent an accident and confirm that the sewing machine will not operate even when depressing the foot pedal of the sewing machine.
12. 为了防止缝纫机落下造成人身事故，搬运缝纫机时请不要手拿缝台护罩。拿缝台护罩后护罩会打关，缝纫机会掉下来。
12. To protect against personal injury resulting from possible drop of the machine, do not carry your machine by holding the cloth plate cover by hand. Doing so may cause the cover to open or break resulting in drop hazards.

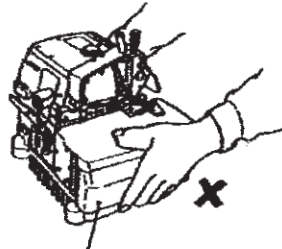

缝台外罩
Cloth plate cover

关于安全装置 SAFETY DEVICE

说明书所记述的机器和安全装置对有的出口地区和规格可能与说明内容略有不同。
Safety devices herein described may differ in accordance with the destination and specifications.

眼睛保护外罩
Eye guard cover

这是防止因机针折断等零件的飞散造成眼睛、头部等伤害的外罩。
A cover to prevent the injury to the eyes, the head or the like due to the dispersion of components such as the broken needle.

安全标牌
Safety label

此标牌上记载有安全方面的注意事项。
Cautions on safety are described.

手指防护器
Finger guard

这是防止手指和机针接触造成伤害的防护外罩。
A cover to prevent the injury due to the contact of fingers with the needle.

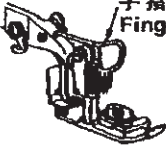

手指防护器
Finger guard

皮带外罩
Belt cover

这是防止因手、头发、衣服卷入皮带造成伤害的防护外罩。
A cover to prevent the hands, the fingers and the clothes from being caught with the V belt.

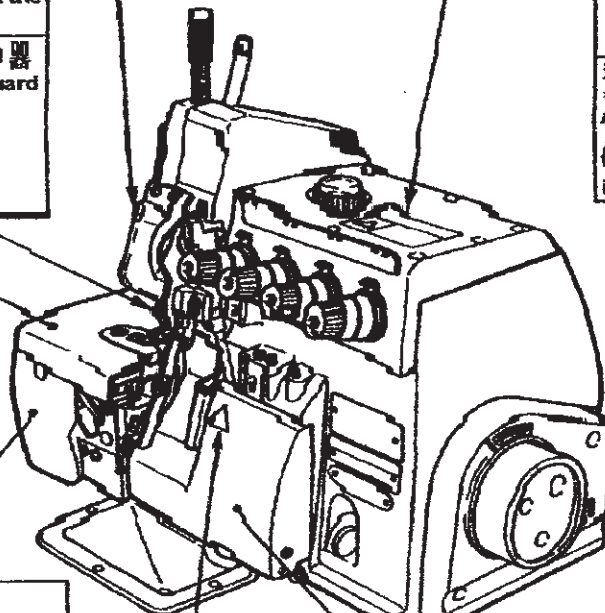

缝台、缝台外罩
Cloth plate, Cloth plate cover

这是防止手、手指、头发、衣服卷入旋转轴造成伤害的防护外罩。
Covers to prevent the injury to the hands, the fingers and hair of the head, and the damage to the clothes by being caught with the rotating shafts.

弯针外罩
Looper cover

这是防止手、手指接触挑线杆造成伤害的防护外罩。
A cover to prevent the injury due to the contact of hands and fingers with the thread take-up lever.

防止手指负伤的注意标牌
Caution label for the injury to the fingers

机器运转中请不要把手、手指等靠近切刀，以免发生负伤事故。
Do not allow your hands, fingers, etc. to come close to the knife to prevent the injury caused by the knife.

目 录

CONTENTS

I. 规格.....	6
I. SPECIFICATIONS	7
II. 安装.....	7
II. INSTALLATION	7
1. 机架板的安装.....	7
1. INSTALLING THE FRAME SUPPORT PLATE	7
2. 皮带罩的安装.....	9
2. ATTACHING THE BELT COVER	9
3. 皮带的安装方法.....	9
3. INSTALLING THE PEDALS	9
III. 准备和运转.....	10
III. PREPARATION AND OPERATION	10
1. 加油.....	10
1. LUBRICATION	10
2. 旋转方向的确认.....	11
2. CHECKING THE DIRECTION OF ROTATION	11
3. 机针的安装方法.....	11
3. ATTACHING NEEDLES	11
4. 穿线的方法.....	12
4. THREADING THE MACHINE	12
5. 压脚的调节和压脚的拆卸方法.....	13
5. ADJUSTING THE PRESSURE OF THE PRESSER FOOT AND REMOVING THE PRESSER FOOT	13
6. 缝距长度的调节.....	13
6. ADJUSTING THE STITCH LENGTH	13
7. 差动送布的调节.....	13
7. ADJUSTING THE DIFFERENTIAL FEED	13
IV. 维修保养.....	14
IV. MAINTENANCE	14
1. 切刀和包边宽度的调整.....	14
1. ADJUSTING THE KNIVES AND OVEREDGE WIDTH	14
2. 缝纫机机头的清扫.....	14
2. CLEANING THE MACHINE HEAD	14
3. 滤清器和泵网的清扫.....	15
3. CLEANING THE FILTER AND PUMP NET	15
4. 皮带轮和皮带.....	15
4. MOTOR PULLEY AND V BELT	15
5. 弯针调整和针板调节尺寸.....	16
5. DIMENSIONS USED TO ADJUST THE LOOPER AND THE NEEDLE GUARD	16
6. 挑线杆、底线凸轮位置尺寸(标准调整).....	18
6. DIMENSIONS RELATED TO THE POSITION OF THE THREAD TAKE-UP AND THE LOOPER THREAD CAM (STANDARD ADJUSTMENT)	18
7. 机针号码对照表.....	19
7. CONVERSION TABLE OF THE NEEDLE NUMBER	19

I. 规格

I. SPECIFICATIONS

	GN880-3	GN880-4	GN880-5
缝制速度 Sewing speed	最高每分钟 6,500 针 Max.6,500 rpm 除一部分派生机种外 (Excluding some subclass models)		
缝距长度 Stitch length	1.0 ~ 3.6 mm		1.5 ~ 3.6 mm
针宽 Needle gauge	-	2.0mm	3.2, 4.8 mm
包边宽度 Overedge width	4.0 mm		4.0, 4.8, 6.4 mm
差动送布比 Differential feed ratio	缩短缝 Gathering stitch 1:1.9 (最大 Max. 1:2.9), 伸长缝 Stretching stitch 1:0.8 (最大 Max. 1:0.6)		
使用机针 Needle	DC x 27 (标准 Standard) DC x 1 也可使用 may be used.		
压脚提升量 Presser foot lift	6.5mm 除一部分派生机种外 (Excluding some subclass models)		
使用机油 Lubricating oil	32 号缝纫机专用油 No.32 For special purposes Oil		
声响 Noise	在 5000 转时应不大于 83 分贝 Workplace-related noise at sewing speed $n=5,000 \text{ min}^{-1}$: LPA $\leq 83 \text{ dB (A)}$ Noise measurement according to DIN 45635-48-A-1.		

11. 安装

I. INSTALLATION

1. 机架板的安装

1. INSTALLING THE FRAME SUPPORT PLATE

(1) 台式时

(1) Semi-sunken type

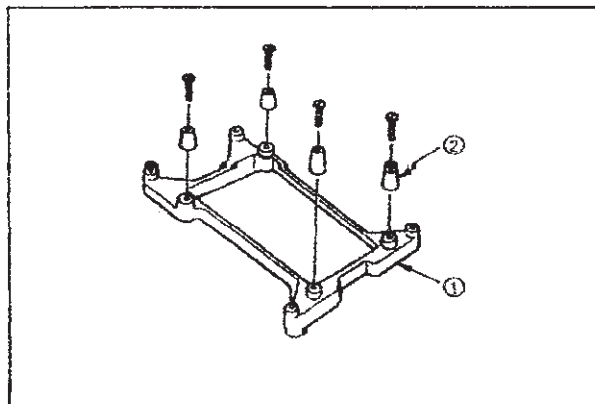

1) 把防震橡胶②安装到机架板上①。

1) Attach rubber cushion ② to frame support plate ①.

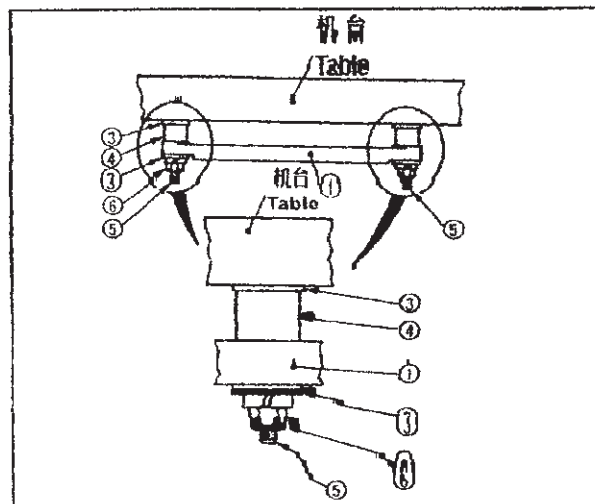

2) 以机台板垫片③、机台板螺栓垫片④、机架板①机架板垫片③的顺序安装到机台上。然后用机台板螺栓⑤和螺母⑥进行固定。

2) Attach support plate washer ③, support plate bolt spacer ④, frame support plate ① and support plate washer ③ in the written order to the machine table. Then fix the frame support plate to the machine table with support plate bolt A ⑤ and nut ⑥.

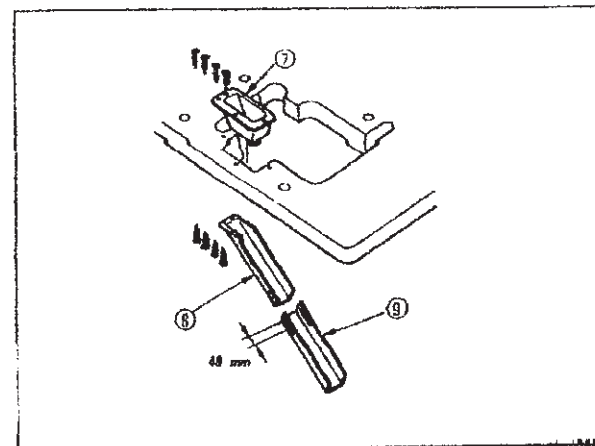

3) 把布屑收集器⑦安装到机台上面的前部。把布屑收集器(上)⑧安装到机台下面。

3) Install waste chute opening ⑦ on the front side of the upper surface of the table, and install waste chute (upper) ⑧ on the bottom face of the table.

4) 把布屑收集器(下)⑨安装到布屑收集器(上)⑧。安装长度可以调整到48mm

4) Install waste chute (lower) ⑨ on waste chute (upper) ⑧

The installation of the chutes can be adjusted within a length of 48 mm.

(2) 落地式时

(2) Fully-sunken type

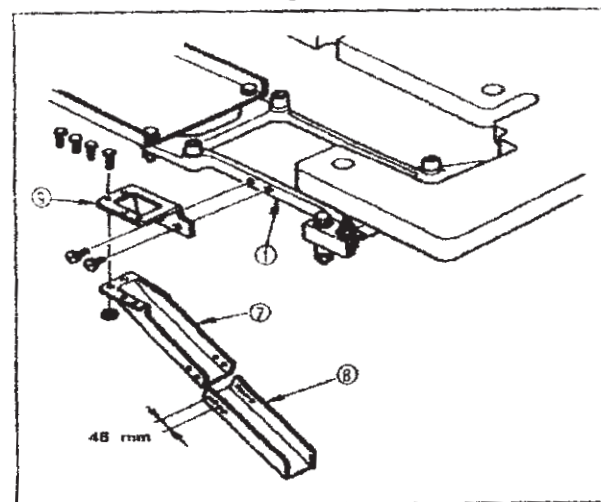
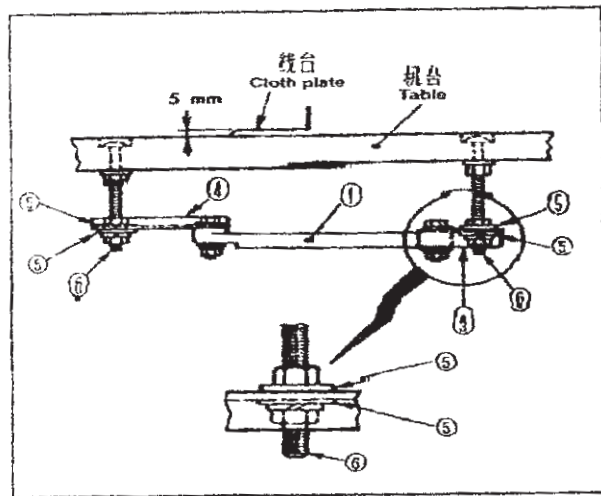
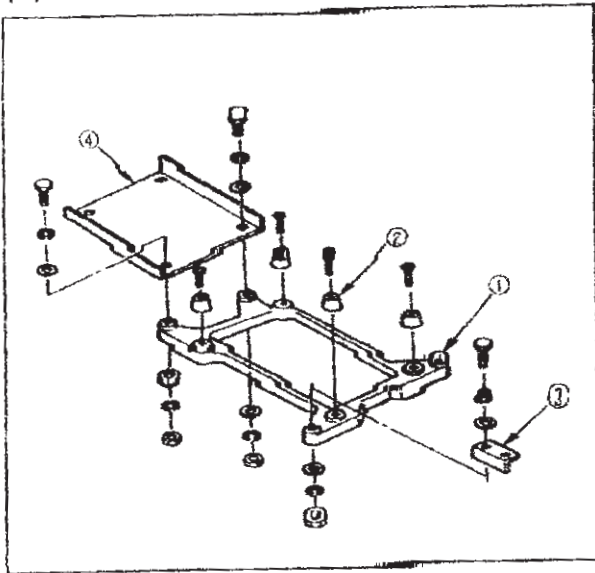

1) 把机架板连接器 A ④、机架板连接器③、防震橡胶②安装到机架板①上。

1) Attach frame support plate joint A ④, frame support plate joint ③ and rubber cushion ② to frame support plate ①.

2) 把机架板螺栓 B ⑥固定机台上。

2) Fix support plate bolt B ⑥ to the machine table.

3) 把机架板连接器 A ④和机架板连接器 B ③分别用机架板垫片⑤挟住。

3) Put frame support plate joint A ④ and frame support plate joint B ③ between support plate washers ⑤ respectively.

○把缝纫机缝台高度调整到离机台上面 5mm 的位置，然后安装好机架台板①。

○ Install frame support plate ① so that the cloth plate is 5 mm higher than the upper surface of the machine table.

4) 把布屑收集器固定板⑨安装到机架板①上。

4) Install waste chute stopper plate ⑨ on frame support plate ①.

5) 把布屑收集器（上部）⑦安装到布屑收集板器固定板⑨上。

5) Install waste chute (upper) ⑦ on waste chute stopper plate ⑨.

6) 把布屑收集器（下部）⑧安装到布屑收集器（上部）⑦上。

6) Install waste chute (lower) ⑧ on waste chute (upper) ⑦.

○安装长度可以在 48mm 范围以内调整。

○ The installation of the chutes can be adjusted within a length of 48 mm.

2. 皮带罩的安装

2. ATTACHING THE BELT COVER



为了防止突然的启动造成人身事故，请关掉电源，确认马达确实停止转动之后再进行操作。
To protect against possible personal injury due to abrupt start of the machine, be sure to start the following work after turning the power off and ascertaining that the motor is at rest.

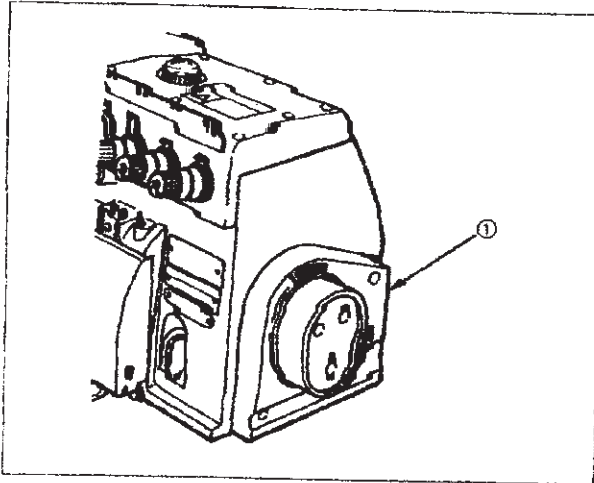

1) 把皮带罩①安装到缝纫机头上。

1) Attach belt cover ① to the machine head.

3. 皮带的安装方法

3. INSTALLING THE PEDALS



为了防止突然的启动造成人身事故，请关掉电源，确认马达确实停止转动之后再进行操作。
To protect against possible personal injury due to abrupt start of the machine, be sure to start the following work after turning the power off and ascertaining that the motor is at rest.

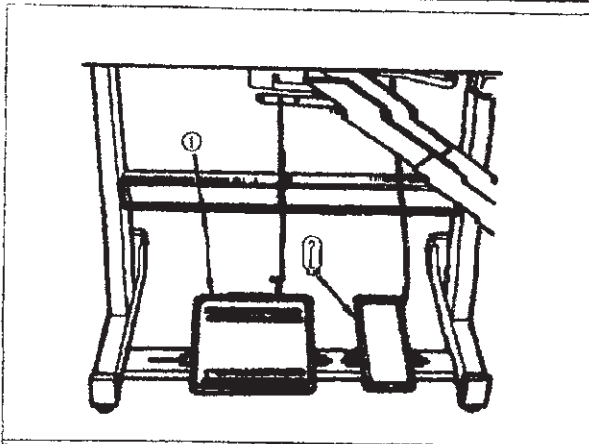

1) 正对缝纫机，把起动踏板①安装到左侧，把压脚提升踏板②安装到右侧。

1) Install starting pedal ① on the left and presser lifter pedal ② on the right as seen from the operator.

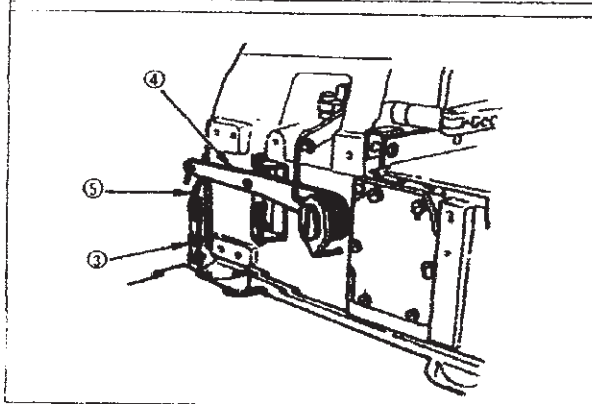

2) 把压脚提升链条③用S形金属附件⑤挂到压脚提升杆④前端的孔上。

2) Use an S-shaped hook ⑤ to connect chain ③ of the presser lifter pedal to the hole located in the top end of presser lifting lever ④

III. 准备和运转

III. PREPARATION AND OPERATION

为了避免机器的错误动作或损坏，请确认如下项目。

To avoid malfunction and damage of the machine, confirm the following:

- 初次使用机器之前，请把机器打扫干净。
- Before you put the machine into operation for the first time after set-up, clean it thoroughly.
- 彻底清扫运输途中积存的灰尘之后进行加油。
- Remove all dust gathering during transportation and oil it well.
- 确认电压设定是否正确。
- Confirm that the voltage has been correctly set.
- 请确认电源插头是否正确地插好。
- Confirm that the power plug has been properly connected to the power supply.
- 电压规格不同时，请绝对不要使用。
- Never use the machine in the state where the voltage type is different from the designated one.

1. 加油

1. LUBRICATION



为了防止突然的起动造成人身事故，请关掉电源，确认马达确实停止转动之后再进行操作。

To protect against possible personal injury due to abrupt start of the machine, be sure to start the following work after turning the power off and ascertaining that the motor is at rest.

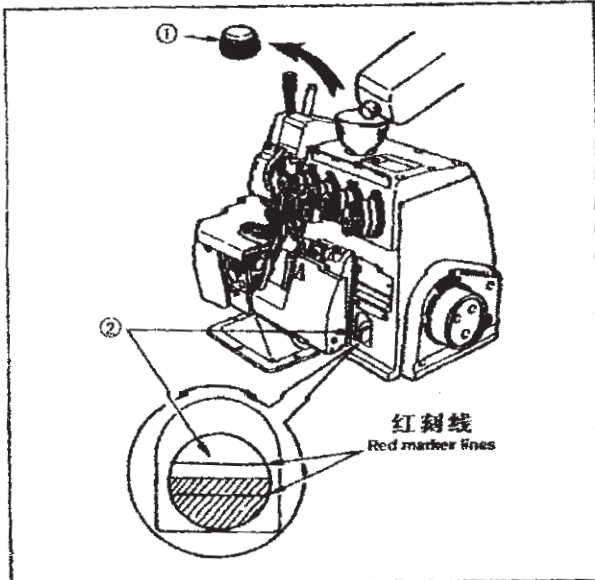

1) 卸下加油孔帽①。

1) Remove oil cap ①.

2) 加入 32 号缝纫机专用油。

2) Pour No.32 for special purposes oil reservoir

3) 观看油尺②，把机油加到 2 条红刻线之间。

3) Supply oil until the oil surface reaches between the two red marker lines when oil gauge ② is observed from the side.

(注意) 1. 如果把油加过上述的红刻线以上，就会因油量过多发生漏油，因此请一定不要加过红线。

(Caution)

1. Be careful not to supply oil above the upper red marker line, or else troubles due to excessive lubrication may result.

2. 加了机油使用之后，第 1 个月，以后每 6 个月请更换一次机油。

2. Change oil when one month has passed after the set-up of the sewing machine. Then, change oil every six months.

3. 观看油尺，油面减少到红线以下后，请进行加油。

3. Supply oil if the oil surface comes down under the lower marker line when observing the oil gauge from the side.

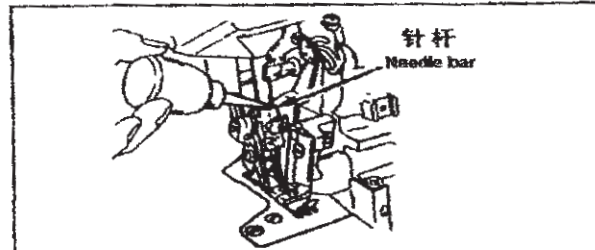

针杆

Needle bar

(注意) 运转新缝纫机时，或运转长时间没有使用过的缝纫机时，请往针杆、上弯针导线器上滴 2~3 滴机油。

(Caution)

Apply two or three drops of oil to the needle bar and upper looper guide portion when operating the machine for the first time after set-up or after a long period of disuse.

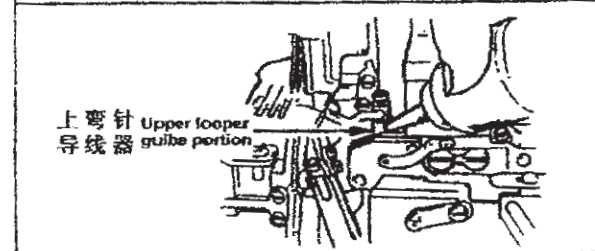

上弯针
导线器

Upper looper
guide portion

2. 旋转方向的确认

2. CHECKING THE DIRECTION OF ROTATION

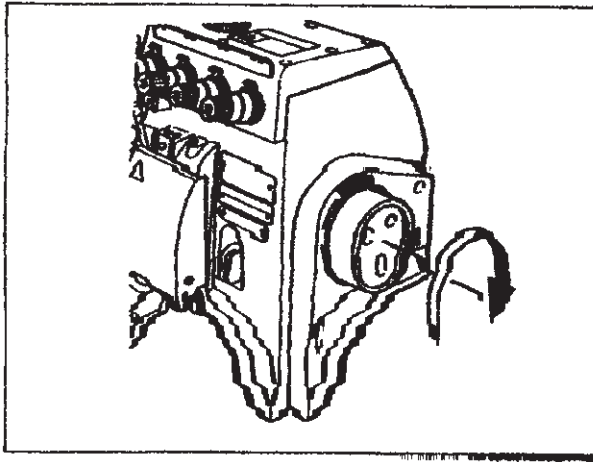

1) 站在飞轮侧看缝纫机的转动方向是顺时针方向。请绝对不要让缝纫机倒转。加油泵不工作会烧坏缝纫机。

1) The correct direction of rotation of the sewing machine is clockwise when observing the machine from the handwheel side.

Never allow the machine to rotate in the reverse direction.

If the machine rotates counterclockwise, the oil pump will

fail to function resulting in seizure.

3. 机针的安装方法

3. ATTACHING NEEDLES



为了防止突然的启动造成人身事故，请关掉电源，确认马达确实停止转动之后再进行操作。
To protect against possible personal injury due to abrupt start of the machine, be sure to start the following work after turning the power off and ascertaining that the motor is at rest.

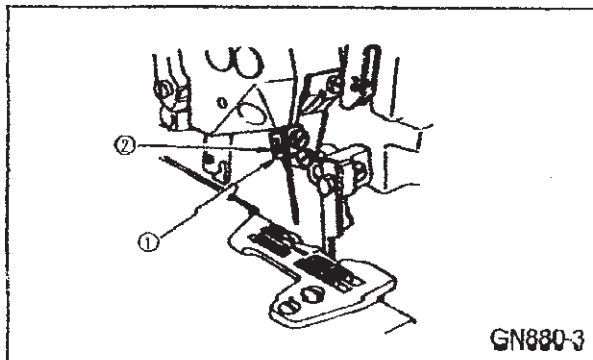

使用的缝纫机针为 DCX27#11。DCX1 也可以使用，但是有时需要调整与弯针的间隙。如果缝制张力要求很严格时，请使用 DCX27。

The standard needle is DC x 27 #11. You can also use the DC x 1 needle. In this case, however, the clearance provided between the needle and the looper may be required to be adjusted. If sewing needs to be carried out with a finely adjusted thread tension, use the DC x 27 needle.

1) 把针夹①上升到最高点。

1) Bring needle clamp ① up to the highest position.

2) 拧松针夹螺丝②，把机针的凹部转向后方，然后把机针插到最里边。

2) Loosen needle clamp screw ②, and fully insert the needle into the needle clamp hole with the needle recess facing backward as viewed from the operator's side.

3) 拧紧针夹固定螺丝②。

3) Tighten needle clamp screw ②.

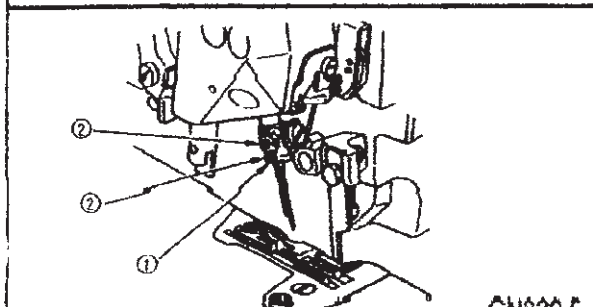
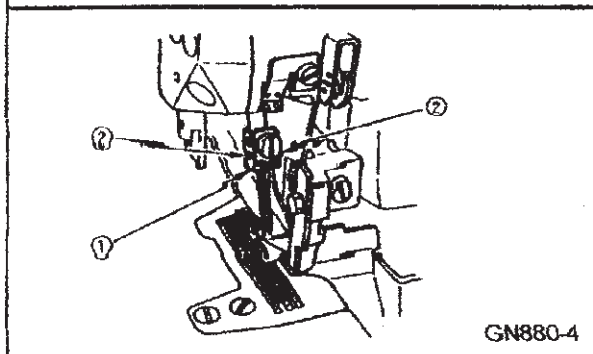

4. 穿线的方法

4. THREADING THE MACHINE



注意



WARNING

为了防止突然的启动造成人身事故，请关掉电源，确认马达确实停止转动之后再进行操作。
To protect against possible personal injury due to abrupt start of the machine, be sure to start the following work after turning the power off and ascertaining that the motor is at rest.

请按图所示进行穿线。(在弯针罩内侧贴上穿线图。)

Thread the machine as shown in the figure. (Threading diagram is pasted inside the looper cover.)

GN880-3

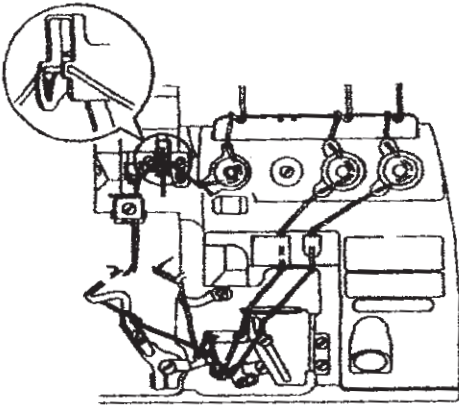

GN880-4

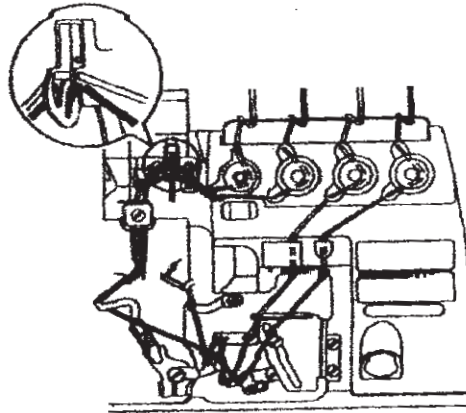

GN880-5

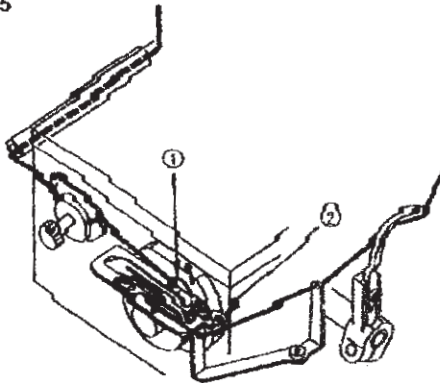

(注意) 向上挑起底线凸轮导线器①穿线以后，返回底线凸轮导线器①，确实地固定到紧线弹簧②。

(Caution) Raise looper thread cam thread guide ① and perform threading. Return looper thread cam thread guide ① to its home position and securely fix it to thread guide spring ②.

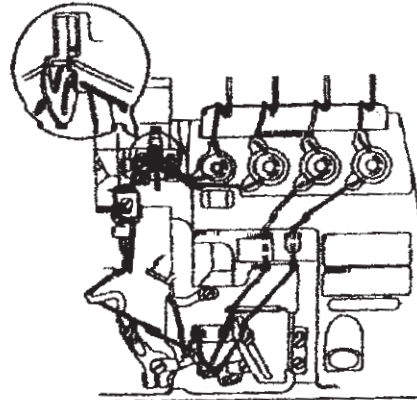

(注意) 双线环时，请一定把线从挑线杆中穿过去。(包缝线在外侧。)

(Caution) Be sure to pass the needle thread for double chainstitch through the needle thread take-up lever.

(Pass the needle thread for overlocking through the thread take-up lever located outside.)

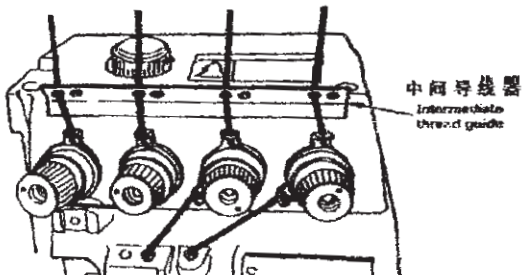

中间导线器
Intermediate thread guide

(注意) 使用尼龙等缝纫机线或较弱的线时，请不要把线绕到中间导线器上。

(Caution) When using an untwisted thread such as wooly nylon thread or weak thread, do not wind it round the intermediate thread guide.

5. 压脚的调节和压脚的拆卸方法

5. ADJUSTING THE PRESSURE OF THE PRESSER FOOT AND REMOVING THE PRESSER FOOT



为了防止突然的起动造成人身事故，请关掉电源，确认马达确实停止转动之后再进行操作。
To protect against possible personal injury due to abrupt start of the machine, be sure to start the following work after turning the power off and ascertaining that the motor is at rest.

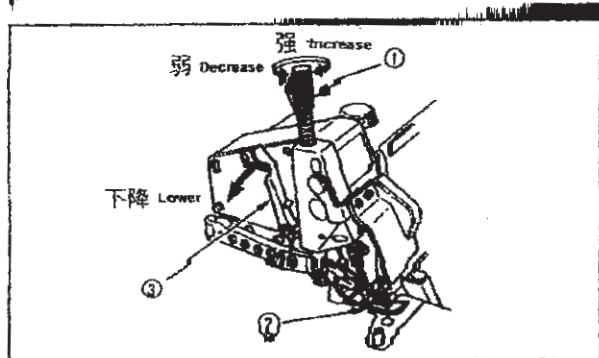

1) 调节压脚时，转动压脚调节螺丝①来进行调整。向右转动压力变强，向左转动压力变弱。

1) Adjust the pressure of the presser foot by turning presser foot adjust screw ①.

When the adjust screw is turned clockwise, the pressure will increase. When it is turned counterclockwise, the pressure will decrease.

2) 横向打开压脚②时，把机针上升到上位，然后放下压脚提升拔杆③。

2) To open presser foot ② sideward, raise the needle to the highest position of its stroke and lower presser bar lifting lever ③.

③

6. 缝距长度的调节

6. ADJUSTING THE STITCH LENGTH



为了防止突然的起动造成人身事故，请关掉电源，确认马达确实停止转动之后再进行操作。
To protect against possible personal injury due to abrupt start of the machine, be sure to start the following work after turning the power off and ascertaining that the motor is at rest.

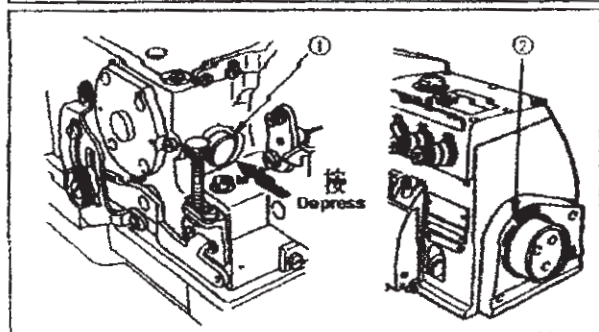

1) 一边按住压脚按钮①，一边转动飞轮，按钮在最里面。

1) Slowly turn the handwheel as you keep depressing pushbutton ①, and you will find a point at which the pushbutton goes in farther.

2) 在此状态，请把飞轮刻度对准皮带罩的标记②。按照刻度使用。

2) With the above condition maintained, align the desired scale mark on the handwheel with mark ② on the belt cover. Use the scale mark as reference.

3) 对准刻度之后，把压脚按钮①返回到原位置。

3) Reset pushbutton ① after setting the scale mark.

7. 差动送布的调节

7. ADJUSTING THE DIFFERENTIAL FEED



为了防止突然的起动造成人身事故，请关掉电源，确认马达确实停止转动之后再进行操作。
To protect against possible personal injury due to abrupt start of the machine, be sure to start the following work after turning the power off and ascertaining that the motor is at rest.

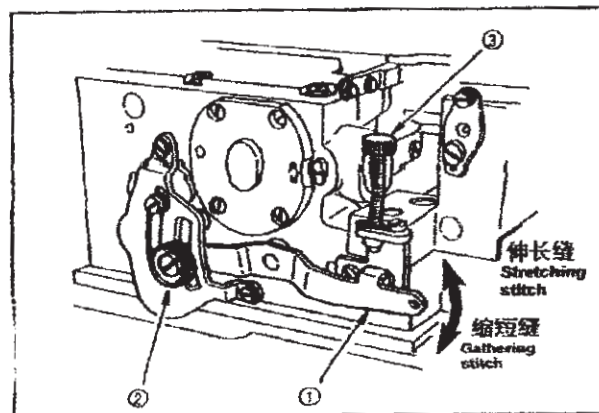

1) 拧松差动锁定螺母②，向上移动差动调节拔杆①可以进行伸长缝，向下移动可以进行缩短缝。

1) Loosen differential feed lock nut ②. Move differential feed adjusting lever ① up for stretching stitch or down for gathering stitch.

2) 如要稍稍移动差动调节拔杆①时，可以使用差动微调螺丝③来调节。

2) When you want to move differential feed adjusting lever ① only slightly, use differential feed fine adjustment screw ③.

3) 扩大①的位置是差动比1:0.8的伸长缝。在刻度0的位置是主送尺轮、副送尺轮的差动比1:1。

3) When the scale mark is set to "1", the machine will perform stretching stitch with a differential feed ratio of 1:0.8, and when it is set to "0", the differential feed ratio between the main feed dog and the differential feed dog will be 1:1.

4) 缩短缝的最大差动比可以达到1:1.9 (但是，调节内部机构可达1:2.9)。0以上的刻度位参考刻度。

4) The maximum differential feed ratio for gathering is 1:1.9 (it can be set up 1:2.9 depending on the adjustment of the internal mechanism of the sewing machine). The scale marks beyond "0" are used as reference.

IV. 维修保养 IV. MAINTENANCE

1. 切刀和包边宽度的调整

1. ADJUSTING THE KNIVES AND OVEREDGE WIDTH

注意 为了防止突然的起动造成人身事故，请关掉电源，确认马达确实停止转动之后再进行操作。
WARNING To protect against possible personal injury due to abrupt start of the machine, be sure to start the following work after turning the power off and ascertaining that the motor is at rest.

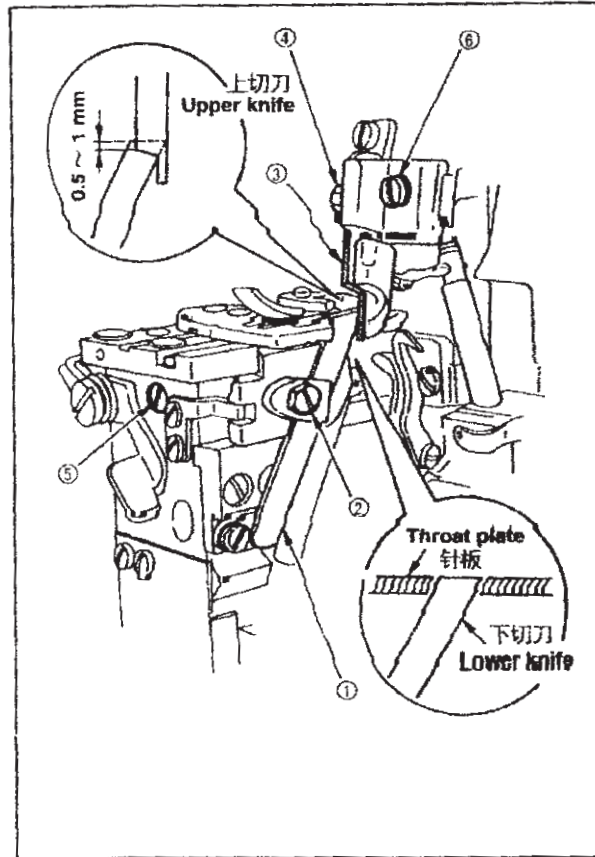

★关于下切刀

★Height of the lower knife

拧松固定螺丝②，把下切刀①的刀尖调整得与针板上表面一致。
Loosen setscrew ② and adjust the height of lower knife ① so that its edge is flush with the throat plate surface.

★关于上切刀

★Height of the upper knife

上切刀③下降到最下点时，拧松固定螺丝④把上切刀调整得与下切刀①相距0.5~1mm。
Loosen setscrew ④ and perform adjustment so that upper knife ③ overlaps lower knife ① by 0.5 to 1 mm when upper knife ③ is at its lowest position.

Loosen setscrew ④ and perform adjustment so that upper knife ③ overlaps lower knife ① by 0.5 to 1 mm when upper knife ③ is at its lowest position.

★关于包边宽度

★Overedge width

更换零件或使用派生机种可以把包边宽度调整到1.6~6.4mm。（包边宽度比切边宽度稍大一点。）
Overedge widths of 1.6 through 6.4 mm are provided by changing the parts or by using subclass models.

(The overedge width will be slightly larger than the knife cut width.)

改变包边宽度时：

To change the overedge width:

- 1) 拧松固定螺丝⑤，向左侧按下切刀①拧紧固定。
1) Loosening setscrew ⑤, push lower knife ① to the left and fix it.
- 2) 拧松固定螺丝⑥，把上切刀③移动需要的距离，然后拧紧固定。
2) Loosen setscrew ⑥ and move upper knife ③ as required, then fix it.
- 3) 把上切刀下降到最下点，拧松固定螺丝⑤，下切刀与上切刀接触之后，拧紧固定螺丝⑤。
3) Lower the upper knife to its lowest point and loosen setscrew ⑤. Tighten setscrew ⑤ when the lower knife comes in contact with the upper knife.

(注意) 1. 使用时，请一定把固定螺丝⑤拧紧固定。
2. 调整后，请确认切线、切布情况。

(Caution)

1. Be sure to tighten setscrew ⑤ before operating machine.
2. After the completion of adjustment, make the knives cut a thread to make sure of sharpness of the knives.

★下切刀的研磨

★Resharpener the lower knife

切刀刀刃变钝之后，请如图所示那样进行研磨。

When the lower knife has become dull, resharpen it as shown in the figure left.

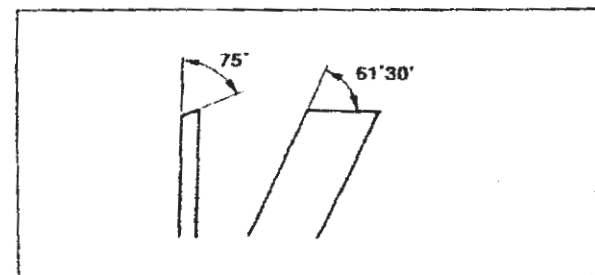

2. 缝纫机机头的清扫

2. CLEANING THE MACHINE HEAD

注意 为了防止突然的起动造成人身事故，请关掉电源，确认马达确实停止转动之后再进行操作。
WARNING To protect against possible personal injury due to abrupt start of the machine, be sure to start the following work after turning the power off and ascertaining that the motor is at rest.

- 1) 请每日清扫1-2次积存在弯针罩内和针杆部的布屑。以防止漏油、弄脏缝制物。
1) Clear lint from inside the looper cover and the needle bar and components about one or twice a day. If not, oil may leak or the sewing material will be soiled.

(注意) 机头的喷漆面，请不要用油漆稀释剂擦拭。以防止损伤喷漆面。

(Caution) Do not wipe the coated surface of the machine head with lacquer thinner. Doing so will damage the coated surface.

3. 滤清器和泵网的清扫

3. CLEANING THE FILTER AND PUMP NET

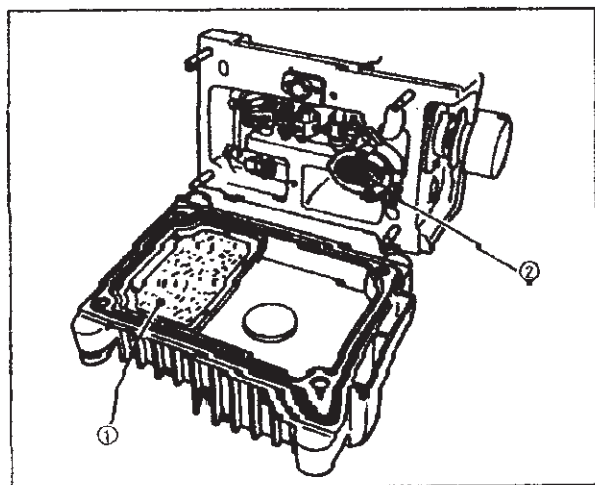

1) 长期使用缝纫机时, 请一定每年清扫 2~3 次滤清器①和泵网②, 滤清器①和泵网②堵塞之后会稍坏机器或造成异常磨损, 请加以注意。

1) To use the sewing machine for an extended period of time, clean filter ① and pump net ② periodically twice or three times a year. If the filter and pump net are clogged with dusts, the machine components may be seized or worn out extraordinarily. So, carefully check the filter and pump net.

2) 如果机油脏污的话, 也请同时更换。

2) If the lubricating oil in the machine is stained, change the oil also at the time of cleaning.

4. 皮带轮和皮带

4. MOTOR PULLEY AND V BELT

缝纫机转速 Number of revolutions of sewing machine (rpm)	50 赫兹 (Hz)			60 赫兹 (Hz)		
	马达皮带轮的外径 Outer diameter of motor pulley (mm)	V形皮带(英寸) V belt (inch)		马达皮带轮的外径 Outer diameter of motor pulley (mm)	V形皮带(英寸) V belt (inch)	
		台式 Semi-sunken type	落地式 Fully-sunken type		台式 Semi-sunken type	落地式 Fully-sunken type
6,500	120	38	32	100	36	32
6,000	110	36	32	85	35	30
5,500	100	36	32	85	35	30
5,000	90	35	30	80	34	30
4,500	80	35	30	70	34	30

1) 本机使用 1/2 马力 (400W) 的离合马达。

1) Use a clutch motor of 1/2 HP (400W)

2) 本机使用 M 型 V 形皮带

2) use an M type V belt.

3) 缝纫机转速和马达皮带轮, 皮带长度的关系如上表所示。



3) Relations among number of revolutions of sewing machine, motor pulley, and length of V belt are as shown in the aforementioned table.

4) 另外, 缝纫机机头的皮带轮有效直径为 50.6mm

4) Effective diameter of the handwheel of sewing machine head is 50.6 mm.

5. 弯针调整和针板调节尺寸

5. DIMENSIONS USED TO ADJUST THE LOOPER AND THE NEEDLE GUARD

 注意	<p>为了防止突然的起动造成人身事故，请关掉电源，确认马达确实停止转动之后再进行操作。 To protect against possible personal injury due to abrupt start of the machine, be sure to start the following work after turning the power off and ascertaining that the motor is at rest.</p>
 WARNING	<p>2. 为了防止因操作不熟练造成的事故，有关调整和更换零件请由熟知机器的维修技术人员或委托本公司、代理店的技术人员进行。 2. To avoid possible accidents due to unfamiliarity with the machine, get a maintenance man who has a good knowledge of the machine or serviceman of our distributor to adjust the machine or replace any of its parts.</p> <p>3. 为了防止因机器起动造成人身事故，请确认螺丝有无松懈，是否有零件相碰之后再使用机器。 3. To avoid possible personal injury when the machine starts, it has to be ascertained in prior to the actuation of the machine that no screws are loosened and no components come in contact with one another.</p>

(注意) 表中的尺寸是使用标准弯针的尺寸。谨供用户参考。需要根据缝制物、机线的不同进行变更调整。
(Caution) The dimensions given in the table are standard ones to be used to adjust the looper. They are intended to be used for reference and should be changed more or less in accordance with the sewing products and thread to be used.

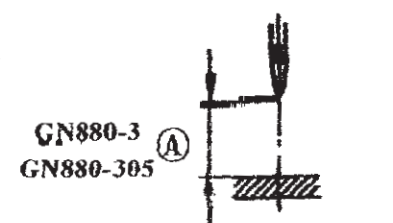
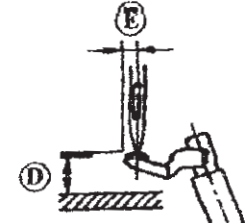
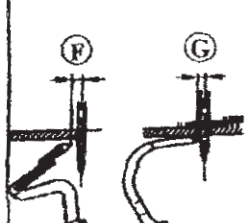
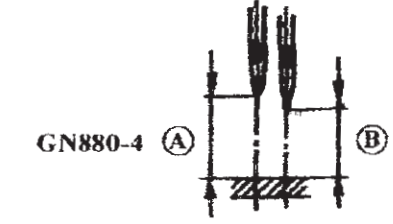
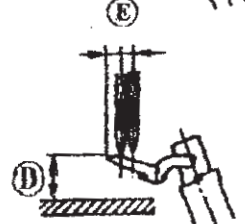
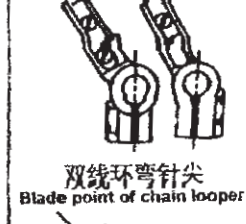
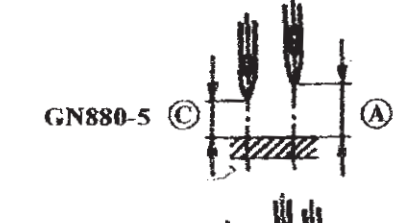
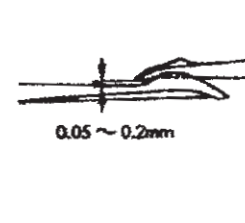
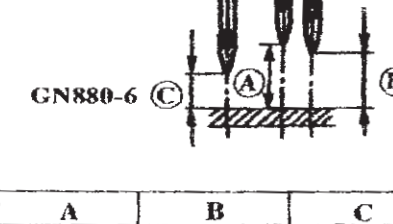
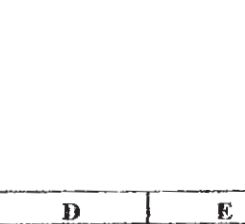
	 <p>GN880-3 (A) GN880-305</p>			 <p>(D) (E)</p>		 <p>(F) (G)</p>	
	 <p>GN880-4 (A) (B)</p>			 <p>(E)</p>		 <p>双线环弯针尖 Blade point of chain looper 0.05 ~ 0.1mm</p>	
	 <p>GN880-5 (C) (A)</p>			 <p>(D)</p>			
	 <p>GN880-6 (C) (A) (B)</p>			 <p>(E)</p>			
	A	B	C	D	E	F	G
GN880-3	11	-	-	11.8	4.8	4	-
GN880-305	11	-	-	11.8	4.8	4	-
GN880-4	11	10.1	-	11.8	4.8	4	-
GN880-5	11	-	9.5	11.8	4.8	4	1.8
GN880-3B	11	-	-	10.5	4.9	4	-
GN880-5-60H	12.6	-	11.1	12.8	4.9	3	1.8
GN880-6	11	10.1	9.5	11.8	4.8	4	1.8

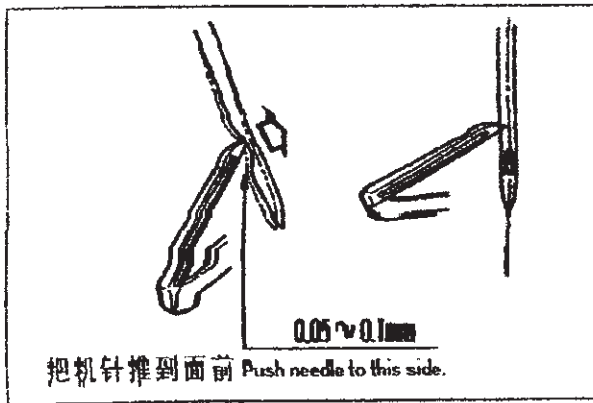

- 1) 把下弯针针尖对准机针中心，把机针往面前推 0.05~0.1mm 调整下弯针。
1) Adjust the lower looper so that the needle is pushed by 0.05 to 0.1 mm to this side by the blade point of lower looper in the state where the blade point of lower looper is aligned with the center of needle.

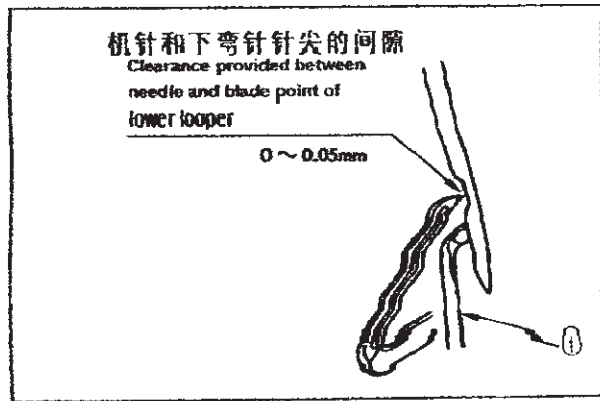

- 2) 然后，用移动针板①把机针推到面前的状态下，调整移动针板①让机针和下弯针针尖の間隙为0~0.05mm。
2) Then, adjust traveling needle guard ① so that the clearance provided between the needle and the blade point of lower looper should be 0 to 0.05 mm in the state where the needle is pushed to this side by traveling needle guard ①.

○请把双针包缝缝纫机的左针和右针都同样进行调整。

○ For the 2-needle overlock machine, adjust both the left and right needles in the same manner.

有关针板 Needle guard components

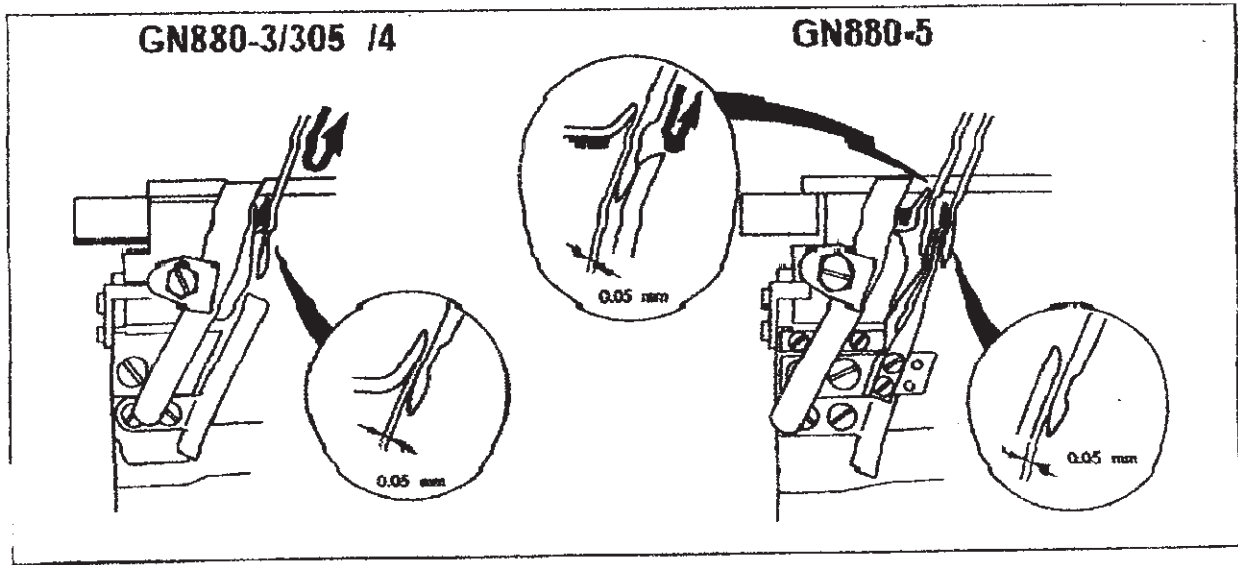

6. 挑线杆、底线凸轮位置尺寸 (标准调整)

6. DIMENSIONS RELATED TO THE POSITION OF THE THREAD TAKE-UP AND THE LOOPER THREAD CAM (STANDARD ADJUSTMENT)



注意



WARNING

为了防止突然的启动造成人身事故, 请关掉电源, 确认马达确实停止转动之后再进行操作。
To protect against possible personal injury due to abrupt start of the machine, be sure to start the following work after turning the power off and ascertaining that the motor is at rest.

(1) 挑线杆、导线器的位置

(1) Position of the needle thread take-up lever and the needle thread guide

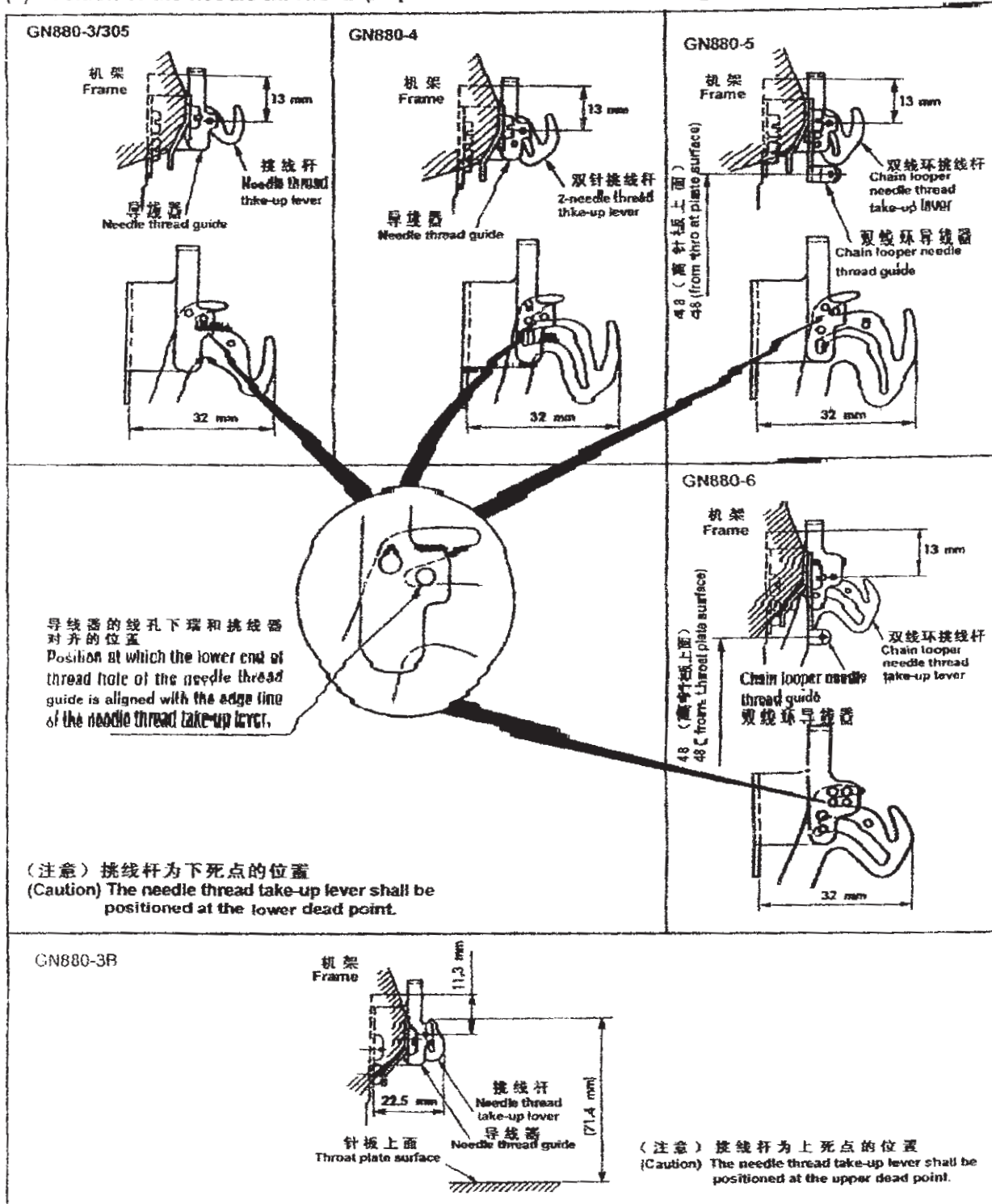

(2) 弯针挑线杆、弯针导线器的位置

(2) Position of the looper thread take-up lever and the looper thread guide

(单位: mm)

(Unit: mm)

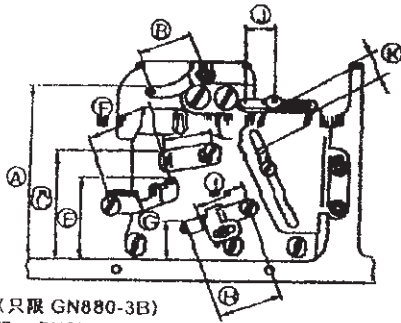

(只限 GN880-3B)
(For GN880-3B only)

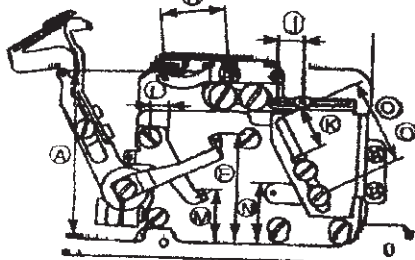

	A	B	C	D	E	F	G	H	I	J	K
GN880-3	68	25	44.5	22	37	26	9	26	22	12	6
GN880-4	↑	↑	↑	↑	↑	↑	8	27	23.5	↑	↑
GN880-5	↑	↑	↑	↑	↑	↑	9	26	22	↑	↑
GN880-305	↑	↑	↑	↑	↑	24	8	26	19	15	18.5
GN880-5-50K	↑	↑	↑	↑	↑	26	↑	30	26.5	12	6
GN880-5-60K	↑	↑	↑	↑	↑	↑	10	↑	↑	↑	↑
GN880-6	↑	↑	↑	↑	↑	↑	8	27	23.5	↑	↑

	A	B	C	D	E	F	G	H	I	J	K			
GN880-3B	68.5	24	-	-	43	-	-	-	10	17	6.8	20	23.5	35

Ⓔ、Ⓕ的尺寸是上弯针在最右点的调整值。
Dimensions of Ⓔ and Ⓕ are adjustment values
when the upper looper is at its rightmost point.

(3) 底线凸轮调整值(GN880-5)

(3) Adjustment value for the looper thread cam (GN880-5)

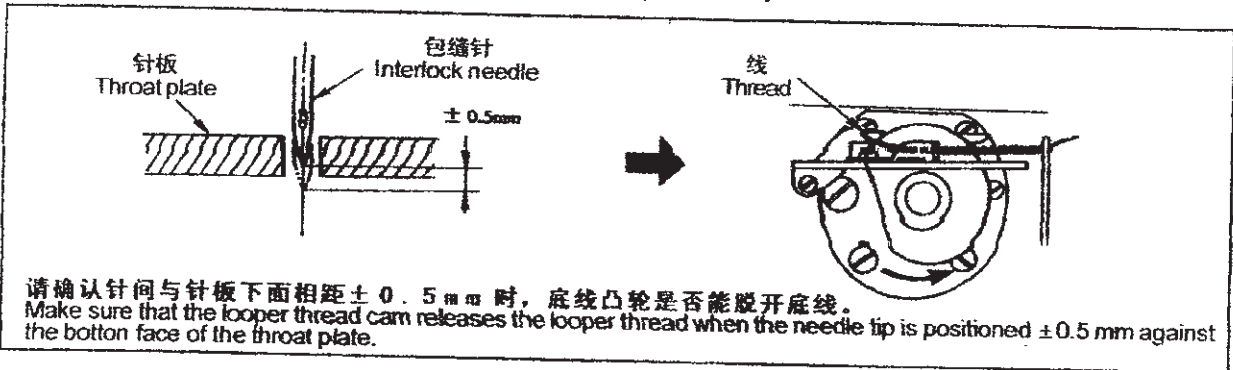

7. 机针号码对照表

7. CONVERSION TABLE OF THE NEEDLE NUMBER

日本针号 (风琴牌) JAPAN(ORGAN)	德国针号 (精密牌) GERMAN(SCHMETZ)
DCx27 #9	B-27 Nm65
DCx27 #11	B-27 Nm75
DCx27 #14	B-27 Nm90
DCx27 #16	B-27 Nm100
DCx27 #18	B-27 Nm110
DCx27 #19	B-27 Nm120
DCx27 #21	B-27 Nm130

目 录

Contents

1	机壳部件	1
	FRAME & MISCELLANEOUS COVER COMPONENTS	
2	主轴部件	3
	CRANKSHAFT COMPONENTS	
3	机针部件	5
	NEEDLE DRIVING SHAFT COMPONENTS	
4	压脚部件 (1)	7
	PRESSER FOOT COMPONENTS (1)	
5	压脚部件 (2)	9
	PRESSER FOOT COMPONENTS (2)	
6	送料部件 (1)	11
	FEED MECHANISM COMPONENTS (1)	
7	送料部件 (2)	13
	FEED MECHANISM COMPONENTS (2)	
8	链线部件 (GN880-5用)	15
	CHAIN LOOPER COMPONENTS (FOR GN880-5)	
9	弯针部件	17
	UPPER & LOWER LOOPER COMPONENTS	
10	过线部件	19
	THREAD TENSION COMPONENTS	
11	油泵部件	21
	LUBRICATION MECHANISM COMPONENTS	
12	上刀部件	23
	KNIFE COMPONENTS	
13	机架台板部件 (桌上式)	25
	SEMI-SUNKEN TYPE TABLE COMPONENTS	
14	机架台板部件 (全沉式)	27
	FULLY-SUNKEN TYPE TABLE COMPONENTS	
15	线架部件	29
	THREAD STAND COMPONENTS	
16	机针冷却部件	31
	NEEDLE COOLER COMPONENTS	
17	附件	32
	ACCESSORIE PART COMPONENTS	

机壳部件

FRAME & MISCELLANEOUS COVER COMPONENTS

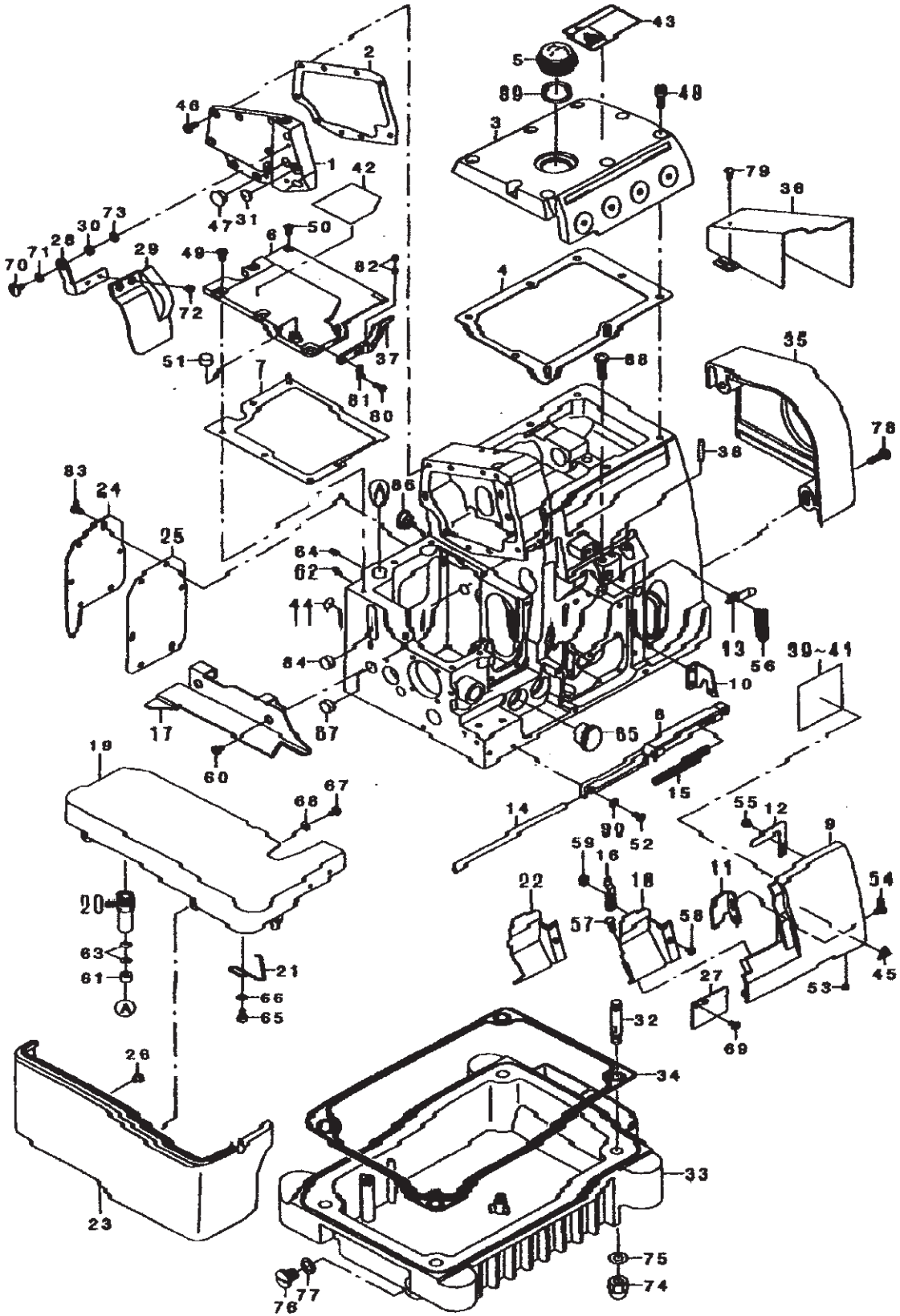

序号 REFNO	NOTE	件号 PART NO.	零件名称	DESCRIPTION	数量 Qty
0		0000000	机壳	MISCELLANEOVS COVER COMPONENTS	1
1		0000107	侧盖	SIDE COVER	1
2		0000206	侧盖垫	SIDE COVER GASKET	1
3		0000305	上盖	UPPER COVER	1
4		0000404	上盖垫	UPPER COVER GASKET	1
5		0000503	注油窗	OIL SIGHT WINDOW	1
6		0000602	送料牙垫圈	FEED MECHANISM COVER	1
7		0000701	送料牙垫圈垫	GASKET	1
8		0000800	弯杆套	LOOPER COVER BRACKET	1
9		0000909	弯杆套	LOOPER COVER	1
10		0001006	弯杆套开槽限位板	LOOPER COVER STOPPER	1
11		0001105	弯杆套衬板	GUIDE PLATE	1
12		0001204	弯杆套压板	PRESSER PLATE	1
13		0001303	弯杆套压簧	PRESSER SPRING	1
14		0001402	弯杆套限位轴	NRNG PIN	1
15		0001501	弯杆套簧	LOOPER COVER SPRING	1
16		0001600	挡屑罩限位挡板	CLOTH WASTE COVER STOPPER	1
17		0001717	挡屑罩盖	CLOTH PLATE SID COVER	1
18	02	0003004	排屑罩 (3/4 挡)	CLOTH WASTE COVER	1
19		0002764	挡屑罩零件	CLOTH PLATE COMPL.	1
20		0002806	偏心轴衬套	ECCENTRIC BUSHING	1
21		0002905	偏心轴衬套簧	CLOTH PLATE SPRING	1
22	01	0003202	排屑罩 (5 挡)	CLOTH WASTE COVER	1
23		0003259	挡屑罩零件	CLOTH PLATE COVER COMPL.	1
24		0003009	送料罩孔盖	COVER	1
25		0003108	送料罩孔盖垫	GASKET	1
26		0002804	挡屑罩盖	RUBBER CUSHION	2
27		0003309	排屑罩 (左)	CLOTH WASTE COVER LEFT	1
28		0003507	护目罩支架	EYE GUARD COVER BASE	1
29		0003705	护目罩	EYE GUARD COVER	1
30		0003804	护目罩支架衬套	EYE GUARD COVER BASE COLLAR	1
31		0003903	护目罩支架衬套	EYE GUARD COVER BASE BUSHING	1
32		0004000	机头取头螺栓	BOLT	4
33		0004109	油盘	OIL RESERVOIR	1
34		0004200	油盘衬垫	OIL RESERVOIR GASKET	1
35		0004307	带轮罩	BELT COVER	1
36		0004407	带轮罩 (B)	BELT COVER B	1
37		0004406	针板支架	THROAT PLATE RETAINER	1
38		0004505	弯杆限位管	THREAD GUIDE LARGE	2
39	03	0005403	三轴穿线圈	THREADING DIAGRAM	1
40	04	0005502	四轴穿线圈	THREADING DIAGRAM	1
41	01	0005601	五轴穿线圈 A	THREADING DIAGRAM	1
42	01	0005700	五轴穿线圈 B	THREADING DIAGRAM	1
43		0005806	安全标志 3	SAFETY LABEL 3(SMALL)	1
44		0006005	电源接地标志	GROUND MARK	1
45		0006704	手柄安全标志	ATTENTION SEAL	1
46		SM-0041055-SP	轴衬套	SCREW	6
47		0107107	轴衬套盖	BUSHING D PLUG	1
48		0119500	上盖螺钉	SCREW	8
49		SM-0040055-SP	牙架螺钉	SCREW	5
50		SM-1040001-SP	牙架螺钉 MAX8.7 L=8	SCREW MAX8.7 L=8	1
51		0106302	挡屑罩橡胶垫 B	CLOTH PLATE RUBBER CUSHION B	1
52	*	SM-0041055-SP	弯杆套螺钉	SCREW	3
53		SM-0040412-TP	弯杆套限位螺钉 M4 L=4	SET SCREW M4 L=4	1
54		SM-0040655-SP	弯杆套限位螺钉 M4 L=6	SCREW M4 L=6	1
55		0110005	弯杆套限位螺钉	SCREW	1
56		SM-0040655-SP	弯杆套限位螺钉 M4 L=6	SCREW M4 L=6	1
57		SM-0040655-SP	排屑罩螺钉 M4 L=6	SCREW M4 L=6	2
58		SS-2000520-SL	排屑罩限位螺钉 M4 L=5	SCREW M4-40 L=5	1
59		NS-0000310-SN	排屑罩限位螺钉 M4 L=5	NUT M4-40	1
60		SM-0040655-SP	挡屑罩螺钉 M4 L=6	SCREW M4 L=6	2
61		0100003	偏心轴衬套	CLOTH PLATE HINGE SHAFT COLLAR	1
62		SM-0030312-TP	偏心轴衬套限位螺钉 M3 L=3	SCREW M3 L=3	1
63		WZ-0420350-KP	偏心轴衬套限位螺钉	DISC SPRING	2
64		SM-0040612-TP	偏心轴衬套限位螺钉 M4 L=6	SCREW M4 L=6	1
65		SM-0040000-SP	偏心轴衬套限位螺钉	SCREW	2
66		WP-0430000-SD	偏心轴衬套限位螺钉 M4	WASHER M4	2
67		SM-0040655-SP	偏心轴衬套限位螺钉 M4 L=6	SCREW M4 L=6	3
68		WP-0430000-SD	偏心轴衬套限位螺钉 M4	WASHER M4	3
69		SM-0040655-SP	排屑罩 (左) 限位螺钉 M4 L=6	SCREW M4 L=6	2
70		0115300	护目罩支架衬套	SCREW	1
71		WZ-0000002-KO	护目罩支架衬套限位螺钉 4.5X12.5X0.3	WAVED WASHER 4.5X12.5X0.3	1
72		SM-0030500-SN	护目罩螺钉 M3 L=6	SCREW M3 L=6	2
73	*	0111505	护目罩限位螺钉	WASHER	1
74		0109103	油盘衬垫限位螺钉	NUT	4
75		0111200	油盘衬垫限位螺钉	WASHER	4
76		0114103	油盘衬垫	WASHER	1
77	*	RO-1007201-OO	排屑罩 O 形密封圈	RUBBER RING	1
78		SM-0051655-SP	排屑罩限位螺钉 M5 L=16	SCREW M5 L=16	2
79		0126000	排屑罩限位螺钉	SCREW	2
80		0124102	排屑罩限位螺钉	SCREW	2
81		WP-0320501-SD	弯杆套限位螺钉	WASHER	2
82		SM-0040412-TP	弯杆套限位螺钉 M4 L=4	SET SCREW M4 L=4	2
83		SM-0040055-SP	主送料罩限位螺钉	SCREW	6
84		0107000	送料罩限位螺钉	RUBBER PLUG	1
85	02	0107204	送料罩限位螺钉	RUBBER PLUG	1
86		0107107	送料罩限位螺钉	BUSHING D PLUG	1
87	02	0107000	送料罩限位螺钉	RUBBER PLUG	1
88		SM-0061255-SP	送料罩限位螺钉 M6 L=12	SCREW M6 L=12	1
89	*	RO-2102401-OO	注油窗 O 形密封圈	RUBBER RING	1
90		WP-0430000-SD	弯杆套限位螺钉 M4	WASHER M4	3
91	*	0115300	轴衬套	SCREW	3

NOTE

01....GN000-5 用
02....GN000-3 用 800-4 用
03....GN000-3 用
04....GN000-4 用

01....FOR 000-5
02....FOR 000-3, 800-4
03....FOR 000-3
04....FOR 000-4

序号 REFNO	NOTE	件号 PART NO.	零件名称	DESCRIPTION	数量 Qty
1	*	8010015	主轴	CRANKSHAFT	1
2		8010106	手轮 (B)	HAND WHEEL B	1
3		8010205	带轮 (A)	HAND WHEEL A	1
4		8010353	主轴承座组件	CRANKSHAFT THRUST COLLAR ASM.	1
5		8010304	主轴承座	CRANKSHAFT THRUST COLLAR	(1)
6		8010403	主轴承座 (A) 盖	BEARING SUPPORT PLATE	(1)
7		8104104	主轴承端向心球轴承 (18200)	CRANKSHAFT BEARING	(2)
8		8010502	轴承垫圈	BEARING RECEIVING PLATE	(1)
9		8112909	波形弹性垫圈	WASHER	(2)
10		SM-6040880-SP	主轴承座 (A) 盖螺钉	SCREW	(3)
11	*	RO-493501-00	主轴承座 O 形密封圈	RUBBER RING	(1)
12		8010601	主轴承挡油圈	OIL SHIELD	1
13		8010700	轴承小挡圈	BEARING RETAINER	1
14		8010809	主轴承套 (B)	CRANKSHAFT BUSHING B	1
15		8010908	主轴承套 (B) 定位螺钉	SCREW	1
16	*	8011112	主轴承套 (C)	CRANKSHAFT BUSHING C	1
17		8011203	主轴承座	CRANKSHAFT BUSHING D	1
18		8011302	主轴承座密封垫	BUSHING B GASKET	1
19		8104005	主轴承端向心球轴承 (180100)	BUSHING D BEARING	1
20	01	8107107	主轴承座 (D) 橡胶塞	BUSHING D PLUG	1
21		SM-8060612-TP	主轴承油孔封油螺钉 A M6 L=6	SCREW M6 L=6	3
22		SM-8040310-SS	主轴承油孔封油螺钉 B M4 L=3	SCREW M4 L=3	4
23		8119706	手轮 (B) 螺钉	SCREW	3
24		8110606	手轮 (B) 垫圈	WASHER	2
25		SM-8061212-TP	带轮 (A) 定位螺钉 M6 L=12	SCREW M6 L=12	1
26		SM-6061602-TP	带轮 (A) 紧固螺钉 M6 L=16	SCREW M6 L=16	1
27		8111000	带轮 (A) 垫圈	WASHER	1
28		SM-6051600-SP	主轴承座 (A) 螺钉 M5 L=16	SCREW M5 L=16	4
29		SM-6041000-SP	主轴承套 (C) 紧固螺钉 M4 L=10	SCREW M4 L=10	4
30	01	8100309	链条偏心供油孔挡圈	SLIDE BLOCK COLLAR	1
31	01	SM-8040412-TP	链条偏心供油孔挡圈紧固螺钉 M4 L=4	SET SCREW M4 L=4	2
32		8011500	冷却风叶	LEAF WIND	1
33		8121207	冷却风叶螺钉	SCREW	3

NOTE 01...GN880-3, 880-4 用

01...GN880-3, 880-4

3. 机针部件

3. NEEDLE DRIVING SHAFT COMPONENTS

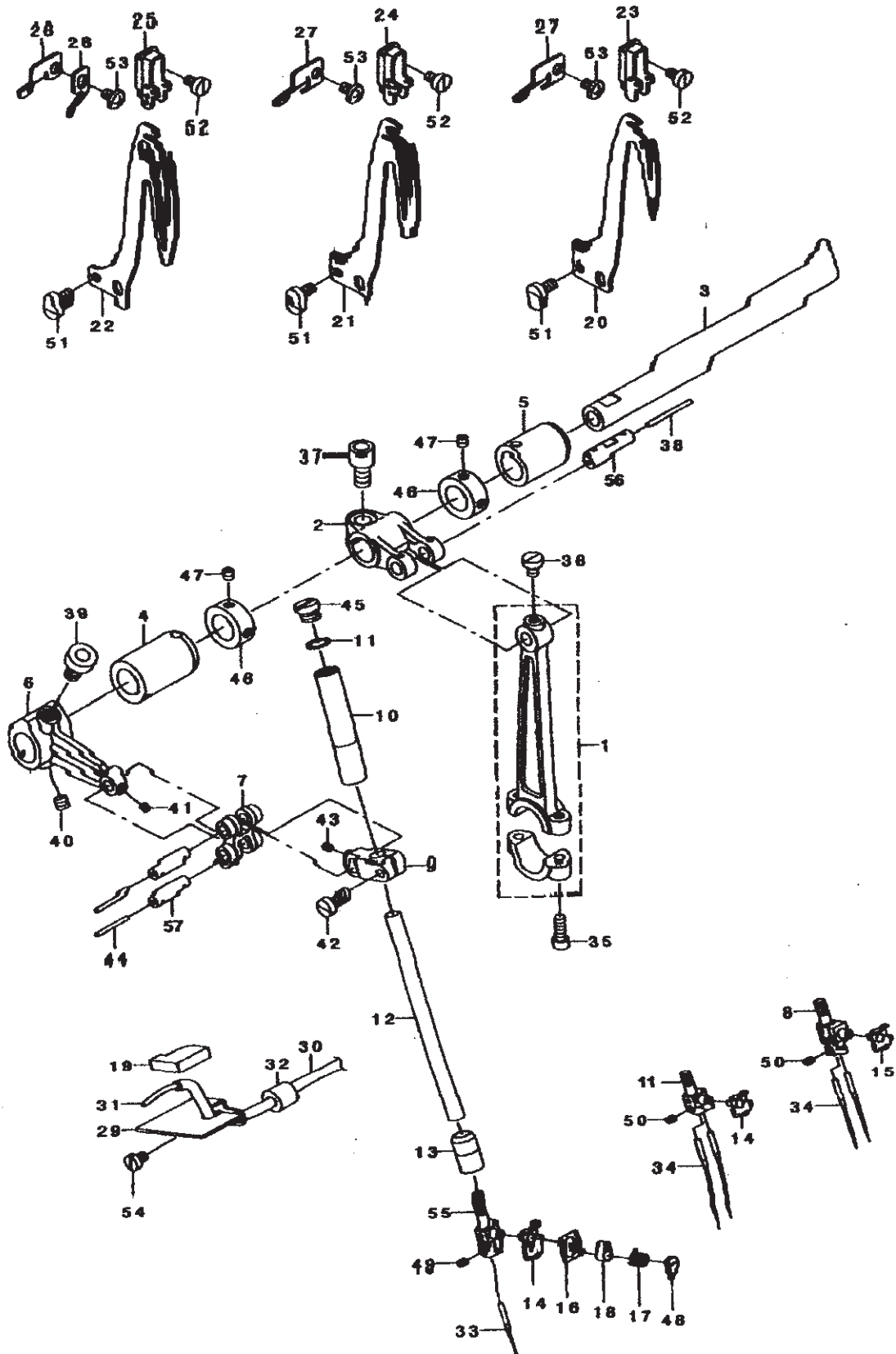

序号 BERNO	NOTE	件号 PART NO.	零件名称	DESCRIPTION	数量 Qty
1		8012508	针杆连杆	NEEDLE DRIVING ROD	1
2		8012607	针杆摇杆	NEEDLE DRIVING FORKED CRANK	1
3		8012805	针杆驱动轴	NEEDLE DRIVING SHAFT	1
4		8012904	针杆驱动轴前轴套	BUSHING, FRONT	1
5		8013001	针杆驱动轴后轴套	BUSHING, REAR	1
6		8013209	针杆曲柄	NEEDLE DRIVING ARM	1
7		8013308	针杆小连杆	NEEDLE DRIVING LINK	1
8	02	8065407	五线针尖 (5线-DE A)	NEEDLE CLAMP, CHAIN LOOPER	1
9		8013506	针杆连轴节	NEEDLE BAR HOLDER	1
10		8013605	针杆上轴套	NEEDLE BAR BUSHING, UPPER	1
11	04	8065100	四线针尖 (4线)	NEEDLE CLAMP, 2-NEEDLE	1
12		8013803	针杆	NEEDLE BAR	1
13		8013902	针杆下轴套	NEEDLE BAR BUSHING, LOWER	1
14	01	8016103	机针线小压板座A	NEEDLE THREAD PRESSER GUIDE A	1
15	02	8014009	机针线小压板座B	NEEDLE THREAD PRESSER GUIDE	1
16		8014207	机针线小压板	NEEDLE THREAD PRESSER PLATE A	1
17		8014405	机针线小压板簧	NEEDLE THREAD PRESSER SPRING	1
18		8014504	机针线小压板套	THREAD GUIDE COLLAR	1
19		8015709	针杆回油罩	FELT A	2
20	03	8014603	机针线挑线杆 (3线)	TAKE-UP LEVER	1
21	04	8014702	机针线挑线杆 (4线)	TAKE-UP LEVER, 2-NEEDLE	1
22	02	8014801	机针线挑线杆 (5线)	TAKE-UP LEVER, CHAIN LOOP	1
23	03	8014900	机针过线板 (3线)	NEEDLE THREAD GUIDE	1
24	04	8015006	机针过线板 (4线)	NEEDLE THREAD GUIDE, 2-NEEDLE	1
25	02	8015105	机针过线板 (5线)	THREAD GUIDE, CHAIN LOOP	1
26	02	8015303	机针线挑线杆导向板 (5线)	TAKE-UP LEVER GUIDE	1
27	01	8015402	机针线挑线杆导向 (3/4线)	TAKE-UP LEVER GUIDE, 2-NEEDLE	1
28	02	8015501	机针线挑线杆导向 (5线-DE A)	TAKE-UP LEVER GUIDE, CHAIN LOOP	1
29		8015600	针杆回油管	COVER	1
30		BP-3000001-00	针杆回油管	VINYL TUBE	0.31
31		CQ-2000000-00	针杆回油管滤芯	OIL WICK	0.32
32	*	8107503	针杆回油管堵套	PLUG	1
33	03	MDC-270B11-00	机针 (DCX27-11#)	NEEDLE DCX27#11	1
34	05	MDC-270B11-00	机针 (DCX27-11#)	NEEDLE DCX27#11	2
35		SM-6041202-TP	针杆连杆螺钉 M4X0.7 L=12	SCREW M4X0.7 L=12	2
36		SM-6040600-SP	针杆连杆紧固螺钉 M4 L=6	SCREW M4 L=6	1
37		SM-6061202-TP	针杆摇杆螺钉 M6 L=12	SCREW M6 L=12	1
38		CQ-2000000-00	针杆连杆油芯	OIL WICK	0.05
39		SM-6061002-TP	针杆曲柄螺钉 M6 L=10	SCREW M6 L=10	1
40		SM-8050502-TP	针杆曲柄紧固螺钉 M5 L=5	SCREW M5 L=5	1
41		SM-8030312-TP	针杆小连杆紧固螺钉 M3 L=3	SCREW M3 L=3	1
42		SM-6041000-SP	针杆连轴节螺钉 M4 L=10	SCREW M4 L=10	1
43		SM-8030312-TP	针杆小连杆紧固螺钉 M3 L=3	SCREW M3 L=3	1
44		CQ-2000000-00	针杆小连杆油芯	OIL WICK	0.04
45		8120605	针杆上轴套螺钉	SCREW	1
46		8100409	针杆驱动轴套圈	THRUST COLLAR	2
47		SM-8040412-TP	针杆驱动轴套圈紧固螺钉 M4 L=4	SET SCREW M4 L=4	4
48		8117205	机针线小压板螺钉	SCREW	1
49	03	SM-8030312-TP	机针螺钉 M3 L=3	SCREW M3 L=3	1
50	05	SM-8030312-TP	机针螺钉 M3 L=3	SCREW M3 L=3	2
51		SM-6040800-SP	机针线挑线杆螺钉	SCREW	2
52		SM-6040600-SP	机针过线板螺钉 M4 L=6	SCREW M4 L=6	2
53		SM-6040655-SP	机针线挑线杆导向板螺钉 M4 L=6	SCREW M4 L=6	1
54		8118104	针杆回油管螺钉	SCREW	2
55	03	8065001	三线针尖	NEEDLE CLAMP	1
56		80162A0	针杆连杆销	CRANK PIN A	1
57		80120A1	针杆小连杆销	LINK PIN C	2

NOTE

01...GN880-3用, 880-4用	01...FOR GN880-3, 880-4
02...GN880-5用	02...FOR GN880-5
03...GN880-3用	03...FOR GN880-3
04...GN880-4用	04...FOR GN880-4
05...GN880-4用, 880-5用	05...FOR GN880-4, 880-5
06...另件选配件	06...FOR SELECTIVE PART

5. 压脚部件 (2)

5. PRESSER FOOT COMPONENTS (2)

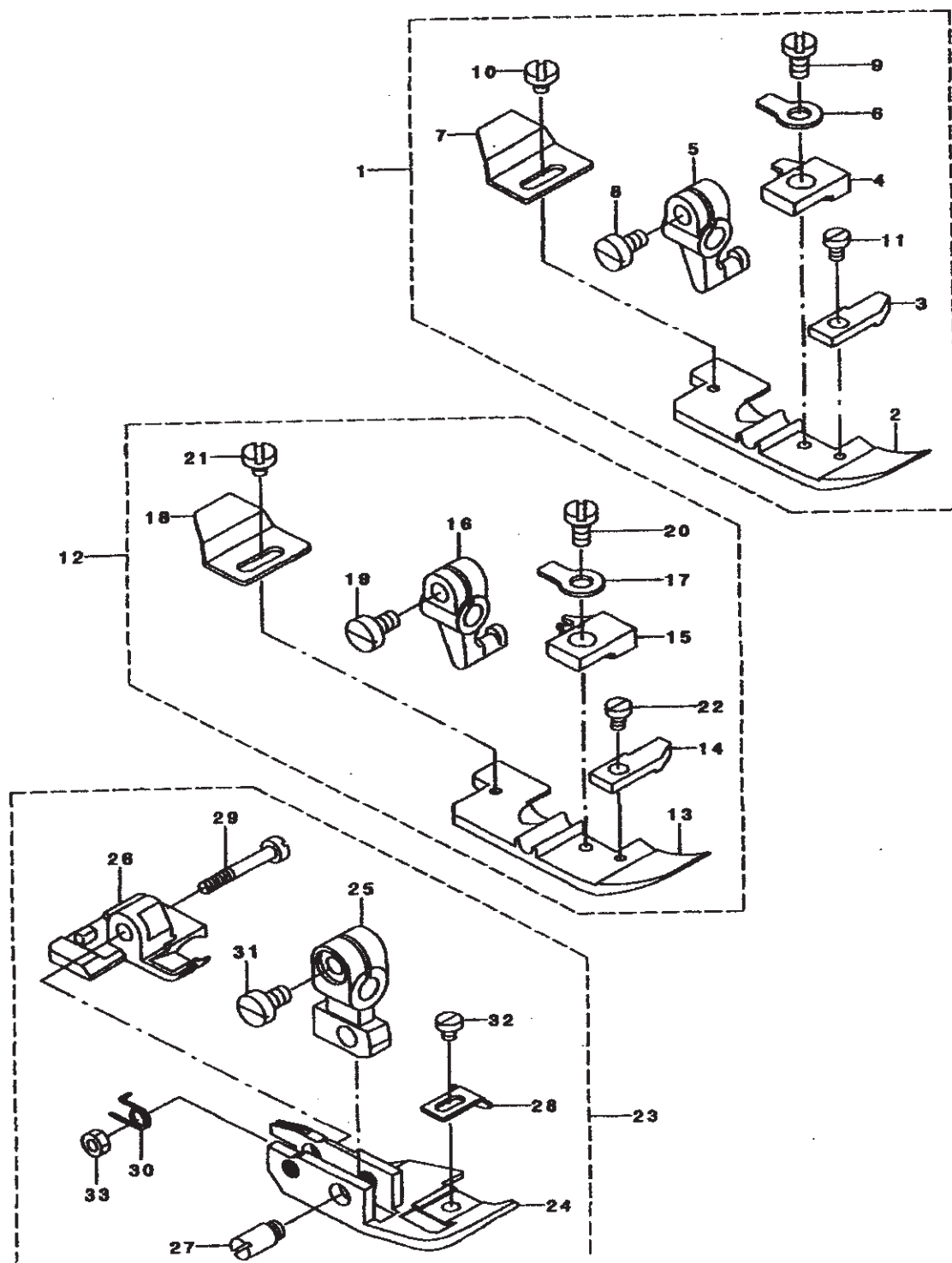

序号 REENO	NOTE	件号 PART NO.	零件名称	DESCRIPTION	数量 Qty
1	01	8066058	压脚组件 (3 线)	PRESSER FOOT ASM.	1
2		8067007	3A 压脚底板	PRESSER FOOT	(1)
3		8067160	三四线辅助压脚	CURL GUARD	(1)
4		8067205	压脚编织导块 (3A5)	STITCH TONGUE	(1)
5		8067304	三四线压脚柄	PRESSER FOOT HINGE	(1)
6		8067403	三四线压脚柄压簧	SPRING	(1)
7		8067502	线辨挡板	REAR PRESSER FOOT	(1)
8	*	SS-6090670-TP	压脚柄螺钉	SCREW 9/64 - 40 L=6	(1)
9		8116306	压脚编织导块螺钉	SCREW	(1)
10		8116207	线辨挡板螺钉	SCREW	(1)
11		SS-6060410-TP	三四线辅助压脚螺钉	SCREW 3/32 - 56 L=3.5	(1)
12	02	8066553	压脚组件 (4 线)	PRESSER FOOT ASM.	1
13		8067809	压脚底板 (4A)	PRESSER FOOT	(1)
14		8067106	三四线辅助压脚	CURL GUARD	(1)
15		8067908	压脚编织导块 (4B6)	STITCH TONGUE	(1)
16		8067304	三四线压脚柄	PRESSER FOOT HINGE	(1)
17		8067403	三四线压脚柄压簧	SPRING	(1)
18		8067502	线辨挡板	REAR PRESSER FOOT	(1)
19	*	SS-6090670-TP	压脚柄螺钉	SCREW 9/64 - 40 L=6	(1)
20		8116306	压脚编织导块螺钉	SCREW	(1)
21		8116207	线辨挡板螺钉	SCREW	(1)
22		SS-6060410-TP	三四线辅助压脚螺钉	SCREW 3/32 - 56 L=3.5	(1)
23	03	8070050	压脚组件 (5 线)	PRESSER FOOT ASM.	1
24		8071009	压脚底板 (5B)	PRESSER FOOT	(1)
25		8071108	五线压脚柄 (5B)	PRESSER FOOT HINGE	(1)
26		8071207	后压脚 (5B)	REAR PRESSER FOOT	(1)
27		8071306	5A 压脚无头轴位螺钉	HINGE PIN	(1)
28		8071405	五线辅助压脚	CLOTH PRESSER	(1)
29		8071504	5A 压脚轴位螺钉	HINGE SCREW	(1)
30		8071603	5A 小压脚扭簧	SPRING	(1)
31	*	SS-6090670-TP	压脚柄螺钉	SCREW 9/64 - 40 L=6	(1)
32		SS-6060340-SP	五线辅助压脚螺钉	SCREW 3/32 - 56 L=2.5	(1)
33		NS-6000210-SP	5A 压脚轴位螺钉螺母	NUT 1/8 - 44	(1)
		NOTE	GN800-3 用	01...FOR GN800-3	
			GN800-4 用	02...FOR GN800-4	
			GN800-5 用	03...FOR GN800-5	

6. 送料部件 (1)

6. FEED MECHANISM COMPONENTS (1)

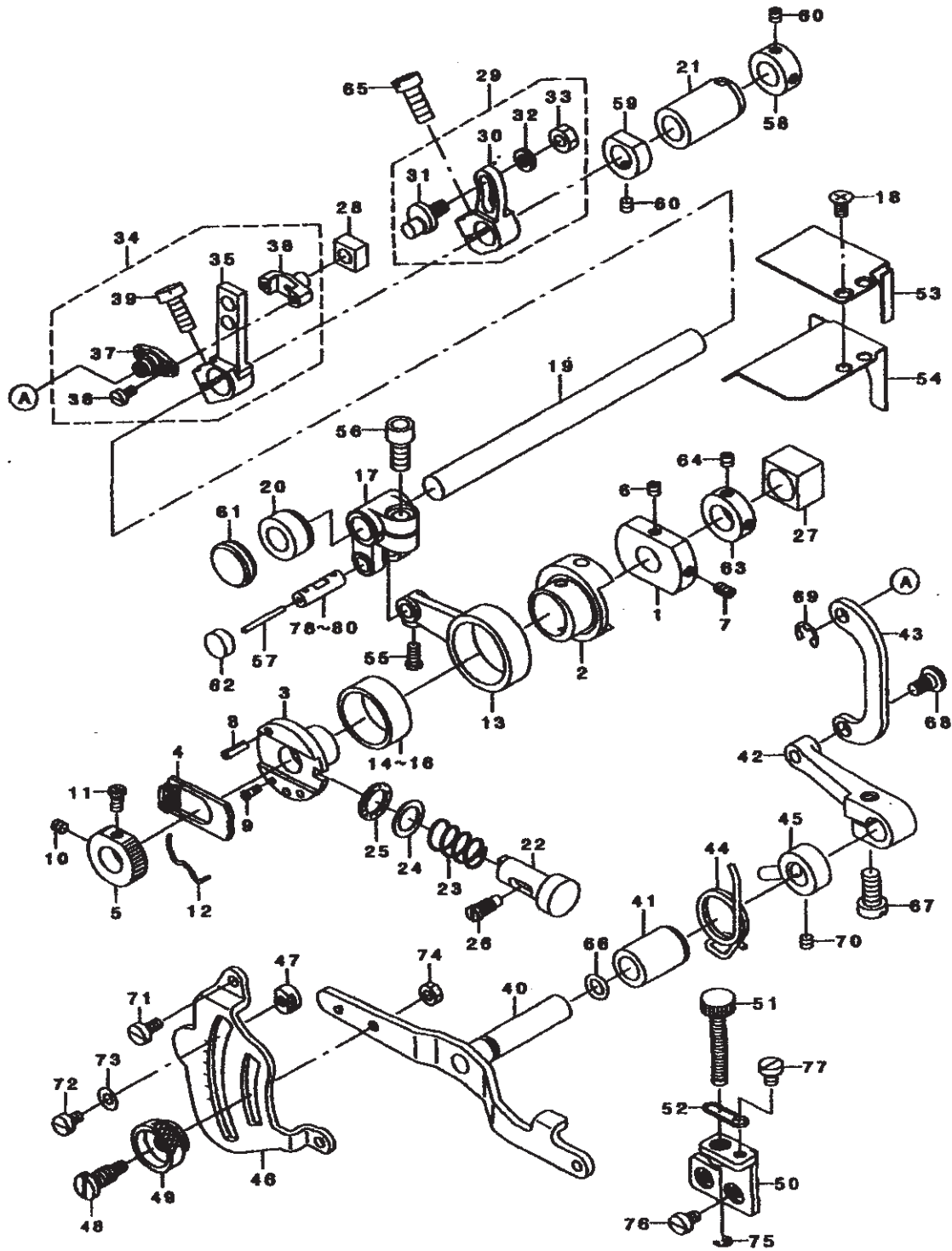

序号 REFNO	NOTE	件号 PART NO.	零件名称	DESCRIPTION	数量 Qty
1		8021004	送料调节偏心座	FEED ECCENTRIC BODY	1
2		8021103	5A 送料偏心	FEED CAM	1
3		8021301	5A 送料调节偏心	FEED ADJUSTING CAM	1
4		8021509	送料调节偏心棘轮爪	RATCHET PAWL	1
5		8021608	送料调节偏心棘轮	RATCHET GEAR	1
6		SM-8040412-TP	送料调节偏心座固定螺钉 4M L-4	SET SCREW M4 L-4	1
7		SM-8040612-TP	送料调节偏心座固定螺钉 4M L-6	SCREW M4 L-6	1
8		8101407	送料调节限位销 G8079-06 3X10	FEED REGULATING PIN	2
9		8117304	送料偏心调节棘轮爪压簧总螺钉	SCREW	1
10		SM-8040412-TP	送料偏心调节棘轮爪固定螺钉 A 4M L-4	SET SCREW M4 L-4	1
11		8118203	送料偏心调节棘轮爪固定螺钉 B	RATCHET GEAR SET SCREW B	1
12		B1606-704-000	送料偏心调节棘轮爪压簧	RATCHET PAWL SPRING	1
13		8021806	送料连杆	FEED CRANK ROD	1
14	01	8021905	送料连杆滚针轴承 A	FEED BEARING A	1
15	01	8022002	送料连杆滚针轴承 B	FEED BEARING B	1
16	01	8022101	送料连杆滚针轴承 C	FEED BEARING C	1
17		8022200	送料连杆	FORKED CRANK	1
18		SM-1040001-SP	送料牙架油板螺钉 M4X0.7 L-8	SCREW M4X0.7 L-8	2
19		8022408	送料轴	FEED SHAFT	1
20		8022507	送料轴前轴套	FEED SHAFT BUSHING, FRONT	1
21		8022606	送料轴后轴套	FEED SHAFT BUSHING, REAR	1
22	*	8027803	送料调节按钮 A	PUSH BUTTON SHAFT	1
23		8022804	送料调节按钮簧	PUSH BUTTON SPRING	1
24		8022903	送料调节按钮轴套	WASHER	1
25	*	8027902	送料调节按钮 B	PUSH BUTTON SHAFT B	1
26	*	8023117	送料调节按钮导向螺钉	PUSH BUTTON SHAFT SCREW	1
27	*	8023216	拾牙滑块	SLIDE BLOCK	1
28		8023703	差动送料牙架滑块	DIFFERENTIAL FEED SLIDE BLOCK	1
29		8023851	主送料曲柄组件	MAIN FEED ROCKER ASM.	1
30		8023902	主送料曲柄	MAIN FEED ROCKER	(1)
31		8027001	主送料曲柄销	PIN	(1)
32		8027100	主送料曲柄销垫圈	WASHER	(1)
33		NS-6620320-SP	主送料曲柄销垫圈 3/16-32	NUT 3/16-32	(1)
34		8023950	差动送料曲柄组件	DIFFERENTIAL FEED ROCKER ASM.	1
35		8023901	差动送料曲柄	DIFFERENTIAL FEED ROCKER	(1)
36		8024008	差动送料曲柄销	PIN	(1)
37		8024107	差动送料曲柄销垫圈	PIN COVER	(1)
38		SM-6030600-SP	差动送料曲柄销固定螺钉 M3X0.5 L-6	SCREW M3X0.5 L-6	(2)
39		8120407	差动送料曲柄螺钉	SCREW	(1)
40		8024552	差动送料曲柄组件	DIFFERENTIAL FEED SHAFT ASM.	1
41		8024701	差动送料曲柄轴套	BUSHING	1
42		8024800	差动送料曲柄	DIFFERENTIAL FEED ARM	1
43		8024909	差动送料曲柄	DIFFERENTIAL FEED LINK	1
44		8025005	差动送料曲柄手压簧	SPRING	1
45		8025153	差动送料曲柄手压簧簧架组件	SPRING BOOK ASM.	1
46		8025203	差动送料曲柄轴套	DIFFERENTIAL FEED GRADUATION	1
47		8025302	差动送料曲柄限位块	STOPPER	2
48		8025401	差动送料曲柄轴位螺钉	HINGE SCREW	1
49		8025500	差动送料曲柄轴螺母	LOCK NUT	1
50	*	8025602	差动送料曲柄轴	SCREW BASE ASM.	1
51		8025807	差动送料曲柄轴	SCREW	1
52		8025906	差动送料曲柄轴	ROTATION STOPPER	1
53	*	8026615	送料牙架油板 (A)	OIL SHIELD A	1
54	*	8026714	送料牙架油板 (B)	OIL SHIELD B	1
55		8115100	送料连杆固定螺钉	SCREW	1
56		SM-4061402-TP	送料连杆螺钉 M6 L-14	SCREW M6 L-14	1
57		CQ-2000000-00	送料连杆油毡	OIL WICK	0.04
58		8100201	送料轴套圈 (厚)	THRUST COLLAR	1
59		8027308	送料轴套圈 (薄)	THRUST COLLAR, THIN	1
60		SM-8040412-TP	送料轴套圈固定螺钉 M4 L-4	SET SCREW M4 L-4	1
61		8107305	送料轴孔塞	RUBBER PLUG	1
62	*	8106901	送料连杆轴套	RUBBER PLUG D=10.3 L=4	1
63	*	8116504	送料调节按钮 B 螺钉	SCREW	1
64	*	RO-0952001-00	送料调节按钮 O 型圈	RUBBER RING	1
65		8120407	主送料曲柄螺钉	SCREW	1
66		8103205	差动送料曲柄手轴 O 型圈密封	RUBBER RING	1
67		8120407	差动送料曲柄螺钉	SCREW	1
68		8113008	差动送料曲柄轴螺钉	HINGE SCREW	1
69		RE-0500000-KO	差动送料曲柄轴轴套开口垫圈	E-RING	1
70		SM-8040412-TP	差动送料曲柄轴套固定螺钉 M4 L-4	SET SCREW M4 L-4	2
71		SM-6040000-SP	差动送料曲柄轴套螺钉	SCREW	2
72		SM-6040000-SP	差动送料曲柄轴套螺钉 M4 L-6	SCREW M4 L-6	2
73		WP-0450701-SD	差动送料曲柄轴套限位圈 4.5X10X0.8	WASHER 4.5X10X0.8	2
74		NM-6040003-SD	差动送料曲柄轴套限位圈 M4	NUT M4	1
75		RE-0300000-KO	差动送料曲柄轴套开口垫圈 3	E-RING 3	1
76		SM-6040000-SP	差动送料曲柄轴套螺钉 M4 L-6	SCREW M4 L-6	2
77		SM-6040000-SP	差动送料曲柄轴套螺钉 M4 L-6	SCREW M4 L-6	2
78	01	8027407	送料连杆 A	FORKED CRANK PIN A	1
79	01	8027506	送料连杆 B	FORKED CRANK PIN B	1
80	01	8027605	送料连杆 C	FORKED CRANK PIN C	1
81	*	8027704	牙架油板	OIL SHIELD	1
82	*	SM-6040000-SP	牙架油板螺钉 M4 L-6	SCREW M4 L-6	2
83	*	SS-5060310-SP	送料牙架油板 (A) 螺钉 3/32-56 L=2.8	SCREW 3/32-56 L=2.8	2

NOTE

01...另件选配件

01...SELECTIVE PART

7. 送料部件 (2)

7. FEED MECHANISM COMPONENTS (2)

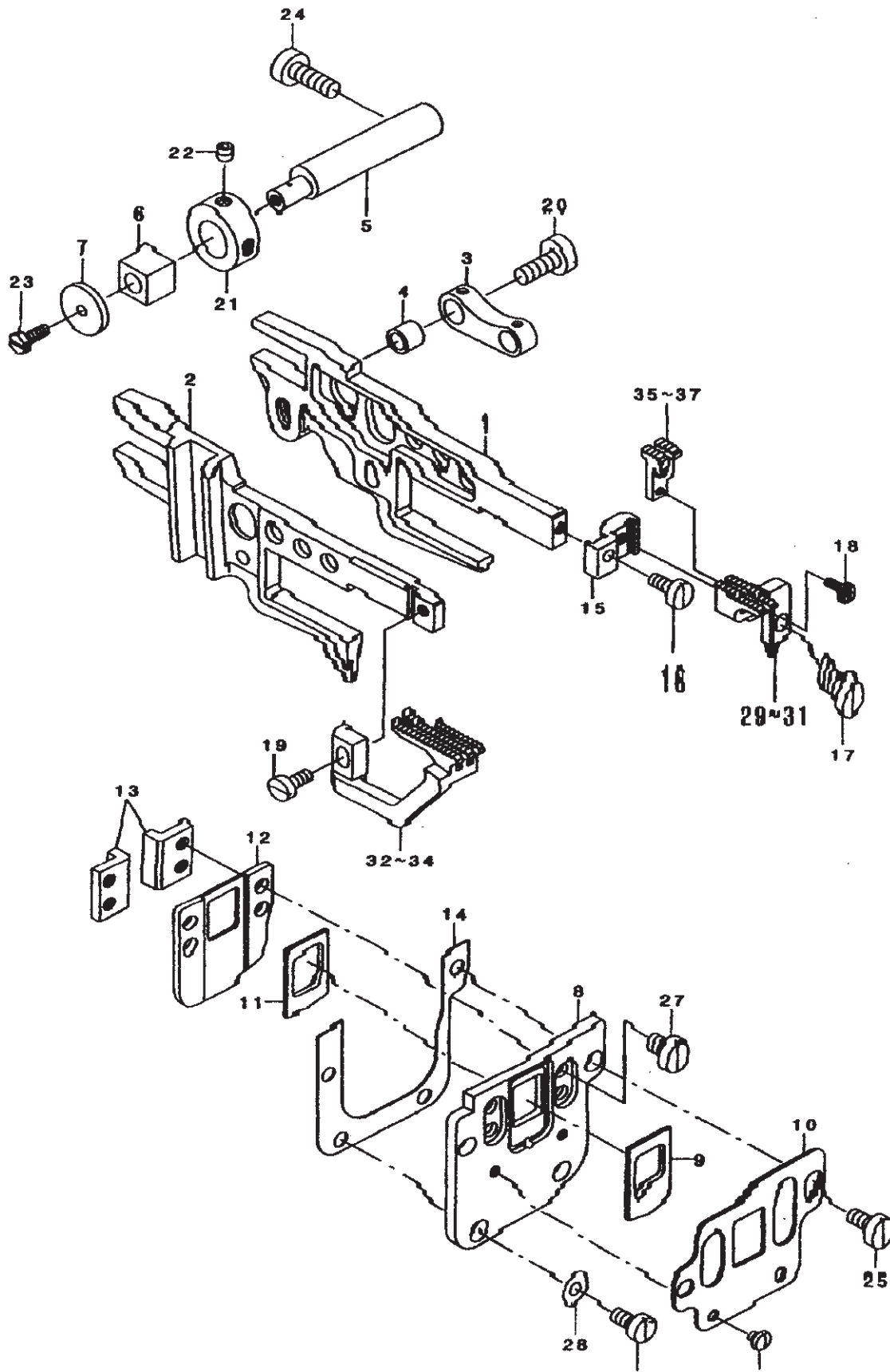

序号 RERNO	NOTE	件号 PART NO.	零件名称	DESCRIPTION	数量 Qty
1	*	8023356	送料牙架组件	FEED BAR ASM.	1
2		8023505	差动送料牙架	DIFFERENTIAL FEED BAR	(1)
3		8023307	主送料牙架	MAIN FEED BAR	(1)
4		8027289	主送料牙架连杆轴承	MAIN FEED LINK COLLAR	1
5	*	8024214	牙架支承偏心轴	FEED BAR SHAFT	1
6		8024305	牙架支承滑块	SLIDE BLOCK	1
7		8024404	牙架支承滑块挡板	WASHER	1
8		8026003	送料牙架防尘橡胶片座	DUST GUARD RUBBER CASE	1
9		8026102	送料牙架防尘橡胶片	DUST GUARD RUBBER	1
10		8026201	送料牙架防尘橡胶片压板	PRESSER PLATE	1
11		8026300	送料牙架挡油橡胶片	OIL SHIELD RUBBER	1
12	*	8026417	送料牙架挡油橡胶片压板	PRESSER PLATE	1
13		8026508	送料牙架左右导向板	FEED BAR SUPPORT	2
14		8026904	送料牙架防尘橡胶片座密封垫	DUST GUARD RUBBER CASE GASKET	1
15		8026805	主送料牙架板	MAIN FEED DOG INSTALLING BASE	1
16		SS-6090810-TP	主送料牙架板螺钉 9/64-40 L=7.5	SCREW 9/64 - 40 L=7.5	1
17		SS-6090810-TP	主送料牙架螺钉 9/64-40 L=7.5	SCREW 9/64 - 40 L=7.5	1
18		8116009	辅助送料牙架螺钉	SCREW	1
19		SS-6090810-TP	差动送料牙架螺钉 9/64-40 L=7.5	SCREW 9/64 - 40 L=7.5	1
20		SS-6121220-TP	主送料牙架连杆螺钉 3/16-28 L=11.5	SCREW 3/16 - 28 L=11.5	1
21	*	8100102	牙架支承偏心轴紧圈	THRUST COLLAR	1
22		SM-8040412-TP	牙架支承偏心轴紧圈固定螺钉 M4 L=4	SET SCREW M4 L=4	1
23		8124102	牙架支承滑块挡板螺钉	SCREW	1
24		SM-6051400-SP	牙架支承偏心轴紧圈固定螺钉	SCREW	1
25	*	SM-6041000-SP	送料牙架防尘橡胶片座螺钉 M4 L=10	SCREW M4 L=10	4
26		8117520	送料牙架防尘橡胶片压板螺钉	SCREW	2
27	*	SM-4040755-SP	送料牙架左右导向板螺钉	SCREW	4
28		WP-0430800-SD	送料牙架防尘橡胶片座垫圈 M4	WASHER M4	2
29	01	8076008	主送料牙 (3A)	MAIN FEED DOG	1
30	02	8076107	主送料牙 (4A)	MAIN FEED DOG	1
31	03	8076206	主送料牙 (5A)	MAIN FEED DOG	1
32	01	8078004	差动送料牙 (3A)	DIFFERENTIAL FEED DOG	1
33	02	8078103	差动送料牙 (4A)	DIFFERENTIAL FEED DOG	1
34	03	8078202	差动送料牙 (5A)	DIFFERENTIAL FEED DOG	1
35	01	8080000	辅助送料牙 (3A)	AUXILIARY FEED DOG	1
36	02	8080109	辅助送料牙 (4A)	AUXILIARY FEED DOG	1
37	03	8080208	辅助送料牙 (5A)	AUXILIARY FEED DOG	1
38		8023604	主送料牙架连杆	MAIN FEED LINK	1
NOTE			01...GN880-3 用	01...FOR GN880-3	
			02...GN880-4 用	02...FOR GN880-4	
			03...GN880-5 用	03...FOR GN880-5	

8. 链线部件

8. CHAIN LOOPER COMPONENTS (FOR GN880-5)

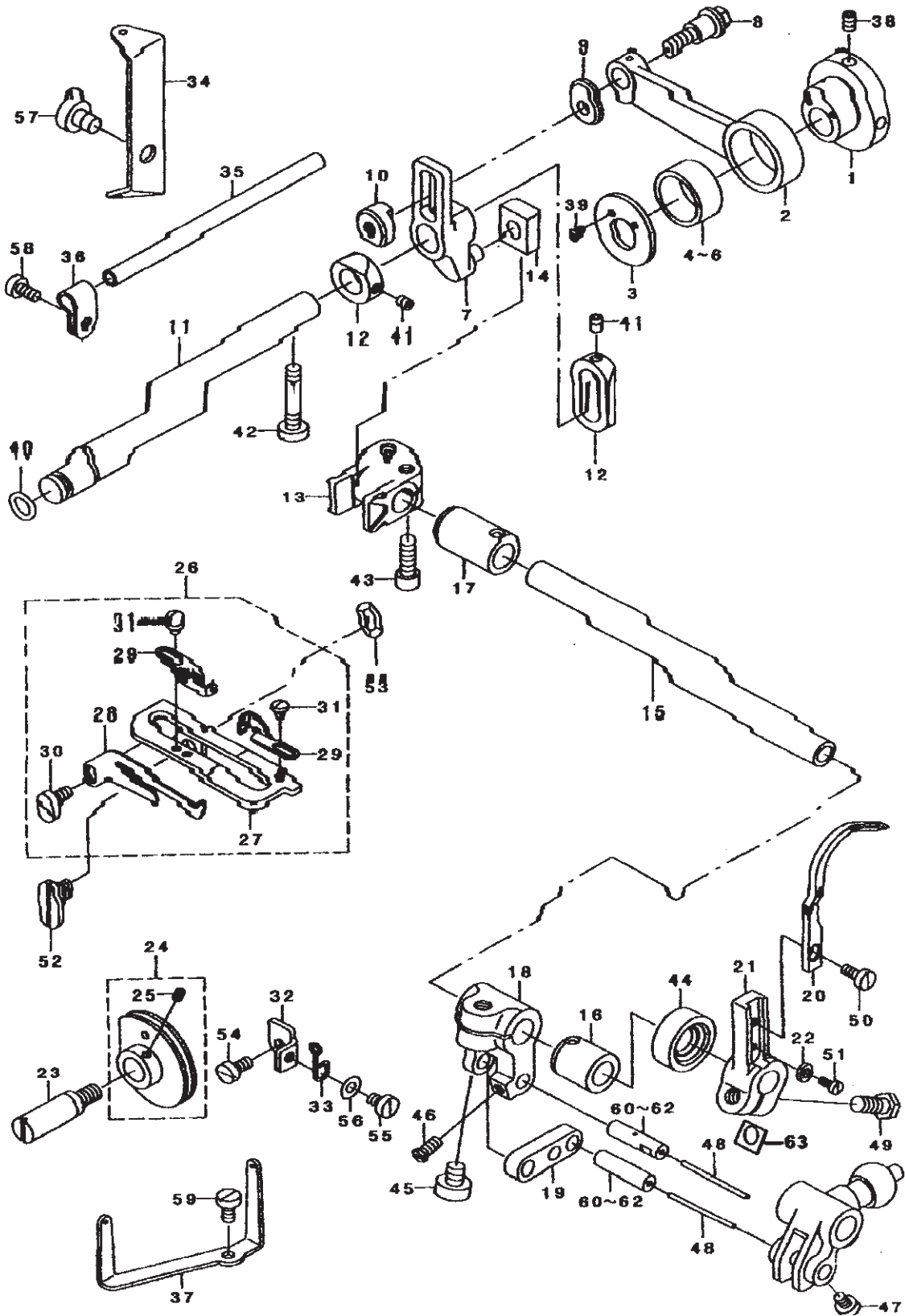

9. 弯针部件

9. UPPER & LOWER LOOPER COMPONENTS

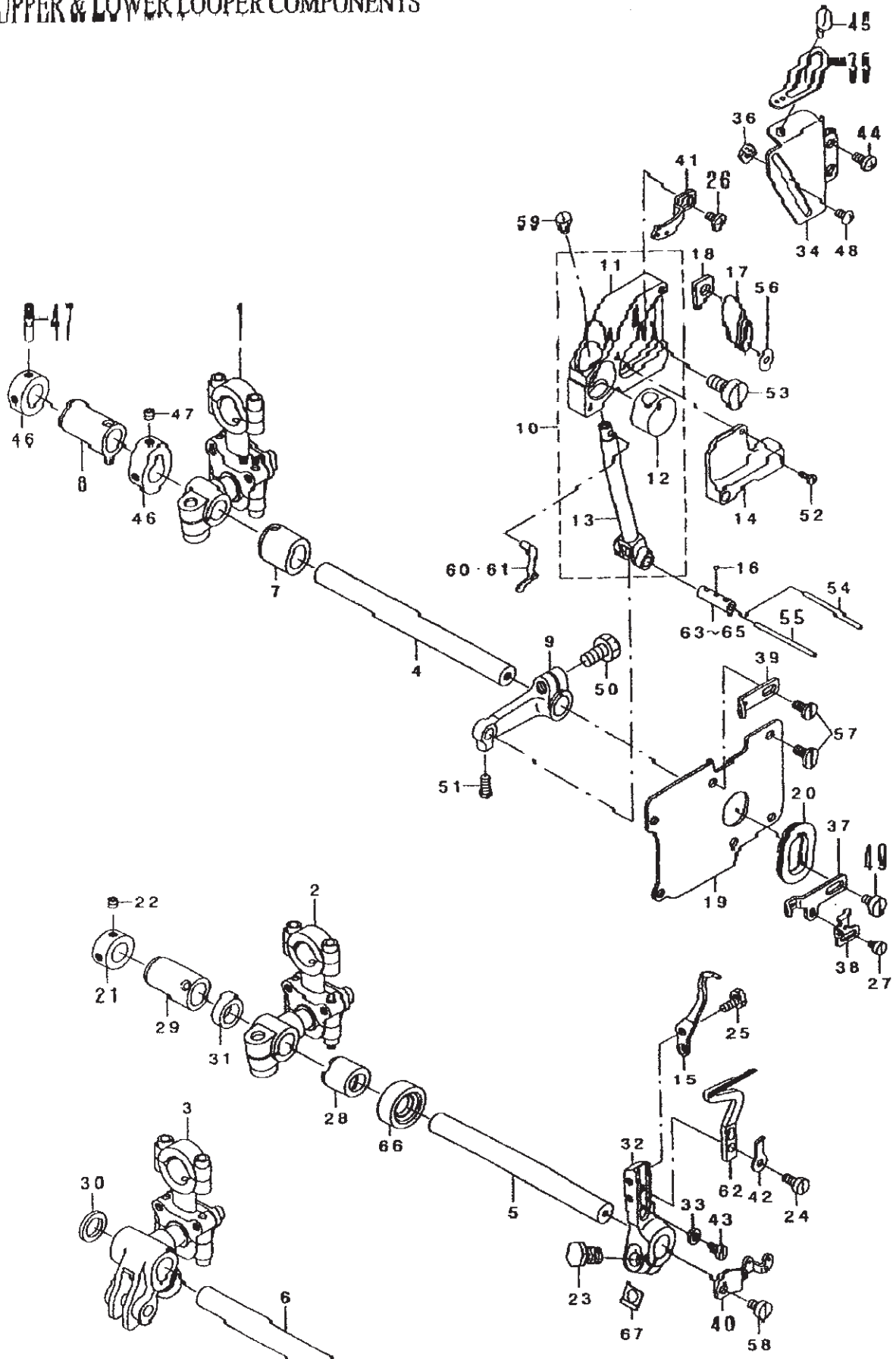

序号 REFNO	NOTE	件号 PART NO.	零件名称	DESCRIPTION	数量 Qty
1	*	8033157	上弯针球曲柄组件	UPPER LOOPER BALL HOLDER ASM.	1
2	*01	8035558	下弯针球曲柄组件 (3/4 线)	BALL HOLDER A ASM.	1
3	*02	8035657	下弯针球曲柄组件 (5 线)	BALL HOLDER B ASM.	1
4	*	8034205	上弯针轴	LOOPER SHAFT	1
5	01	8033306	下弯针轴 (3/4 线)	UPPER LOOPER SHAFT	1
6	02	8035103	下弯针轴 (5 线)	LOWER LOOPER SHAFT	1
7		8029403	弯针轴前轴套	BUSHING, FRONT	1
8		8029502	弯针轴后轴套	BUSHING, REAR	1
9		8033405	上弯针摆杆	LOOPER HOLDER	1
10		8033553	上弯针导套座架组件	LOOPER GUIDE SUPPORT ASM.	1
11		8033504	上弯针导套座	UPPER LOOPER GUIDE SUPPORT	(1)
12		8073108	上弯针导套	UPPER LOOPER GUIDE	(1)
13		8033702	上弯针导杆	UPPER LOOPER HOLDER	(1)
14		8033801	上弯针导套盖	UPPER LOOPER GUIDE COVER	1
15		8084002	摆动护针 (5A)	TRAVELING NEEDLE GUARD	1
16		8034403	上弯针导杆销油线定位钢球	OIL WICK STOP BALL	1
17		8034502	上弯针导套座定位块销	PIN	1
18		8034601	上弯针导套座定位块	GAUGE	1
19		8034700	上弯针导套座挡油板	OIL SHIELD	1
20		8034809	上弯针轴橡胶圈	UPPER LOOPER SHAFT RUBBER RING	1
21	*	8100201	下弯针轴套圈	THRUST COLLAR	1
22	*	SM-8040412-TP	下弯针轴套圈螺钉 M4 L=4	SET SCREW M4 L=4	2
23		8125208	下弯针摆杆螺钉	SCREW	1
24		SS-6090810-TP	下弯针小过线板螺钉 9/64-40 L=7.5	SCREW 9/64-40 L=7.5	1
25		8116405	摆动护针螺钉	SCREW	2
26		SS-4090615-SP	上弯针过线 (中) 螺钉 9/64-40 L=6	SCREW 9/64-40 L=6	1
27		SS-6080410-SP	下弯针挑线螺钉 1/8-44 L=4	SCREW 1/8-44 L=4	1
28	*	8034908	下弯针轴前轴套	BUSHING, FRONT	1
29		8029502	弯针轴后轴套	BUSHING, REAR	1
30	02	8035707	下弯针轴套	SPACER	1
31	01	8035202	下弯针轴套	SPACER	1
32		8035806	下弯针摆杆	LOWER LOOPER ARM	1
33		8030085	下弯针限位挡块	LOWER LOOPER STOPPER	1
34		8040204	弯针线量调节板	LOOPER THREAD TAKE-UP COVER	1
35		8040303	上弯针过线 (右)	THREAD GUIDE, RIGHT	1
36		8040808	下弯针过线	THREAD GUIDE	1
37		8040402	上弯针挑线 (右)	THREAD TAKE-UP, RIGHT	1
38		8040709	下弯针挑线	LOWER LOOPER THREAD TAKE-UP	1
39		8036507	上弯针过线 (中)	THREAD GUIDE, MIDDLE	1
40		8040907	弯针挑线 (左)	LOWER THREAD GUIDE, LEFT	1
41		8040501	上弯针过线 (上)	THREAD GUIDE, UPPER	1
42		8036804	下弯针过线 (左)	THREAD GUIDE, LEFT	1
43		SM-6850600-SP	下弯针限位挡块螺钉	SCREW	1
44		SM-4040855-SP	弯针线量调节板螺钉	SCREW	2
45		SS-3090610-SP	上弯针过线 (右) 螺钉 9/64-40 L=6	SCREW 9/64-40 L=6	1
46		8100201	上弯针轴套圈	THRUST COLLAR	2
47		SM-8040412-TP	上弯针轴套圈固定螺钉 M4 L=4	SET SCREW M4 L=4	4
48		SS-3090610-SP	下弯针过线螺钉 9/64-40 L=6	SCREW 9/64-40 L=6	1
49		SM-6040600-SP	上弯针挑线 (右) 螺钉 M4 L=6	SCREW M4 L=6	1
50		SM-9061250-TP	上弯针摆杆螺钉 M6 L=12	SCREW M6 L=12	1
51		8115100	上弯针导杆销螺钉	SCREW	1
52		SS-7060610-SP	上弯针导套圈螺钉 3/32-56 L=5.5	SCREW 3/32-56 L=5.5	2
53		SM-6061200-SP	上弯针导套圈螺钉	SCREW	2
54		CQ-2000000-OO	上弯针导杆销油芯	OIL WICK	0.04
55		CQ-2020000-OO	上弯针导杆销油芯	OIL WICK	0.04
56		8103007	上弯针导套座定位块 O 形密封圈	RUBBER RING	1
57		8115209	上弯针导套座挡油板螺钉	SCREW	6
58		SM-6040600-SP	下弯针挑线 (左) 螺钉 M4 L=6	SCREW M4 L=6	1
59		SS-9090410-TP	上弯针螺钉	SCREW	1
60	03	8081107	上弯针 (3/5 线)	UPPER LOOPER	1
61	04	8081008	上弯针 (4 线)	UPPER LOOPER	1
62		8081800	下弯针	LOWER LOOPER	1
63	05	8033900	上弯针导杆销 A	UPPER LOOPER HOLDER PIN A	1
64	05	8034007	上弯针导杆销 B	UPPER LOOPER HOLDER PIN B	1
65	05	8034106	上弯针导杆销 C	UPPER LOOPER HOLDER PIN C	1
66		8105507	下弯针轴油封	OIL SEAL RING	1
67	*	8035301	下弯针摆杆垫圈	WASHER	1

NOTE

01...GN880-3 用, GN880-4 用

02...GN880-5 用

03...GN880-3 用, GN880-5 用

04...GN880-4 用

05...另件选配件

01...FOR GN880-3, GN880-4

02...FOR GN880-5

03...FOR GN880-3, GN880-5

04...FOR GN880-4

05...FOR SELECTIVE PART

10. 过线部件

10. THREAD TENSION COMPONENTS

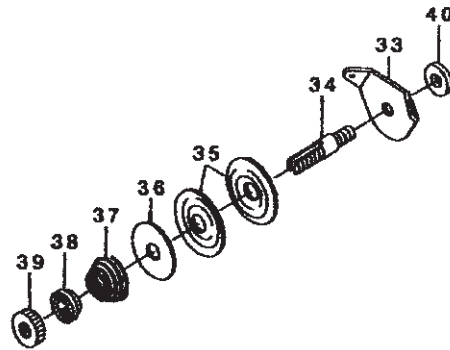
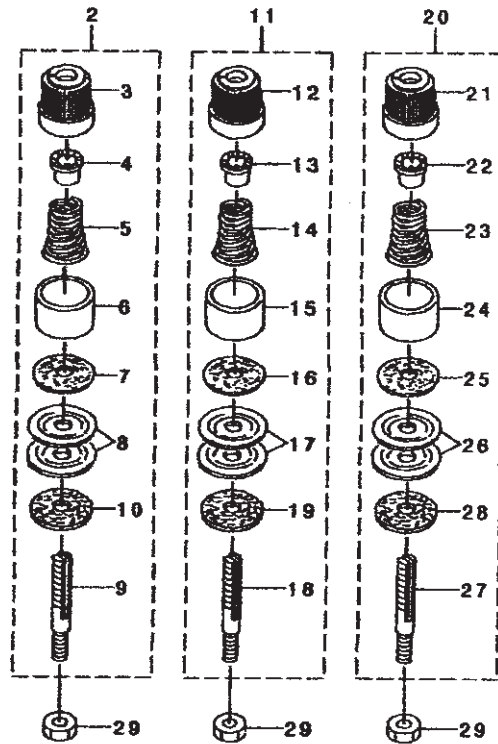
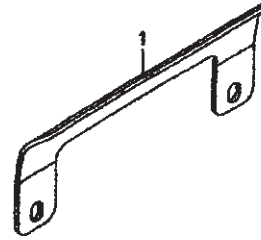
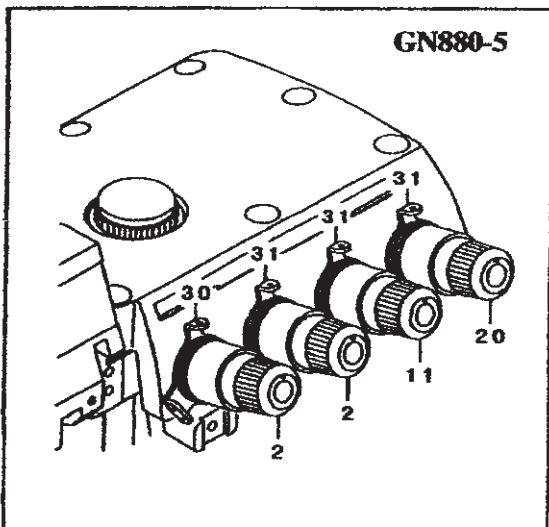
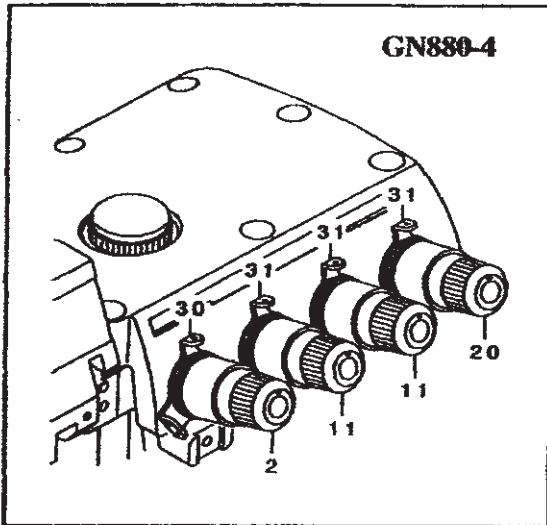
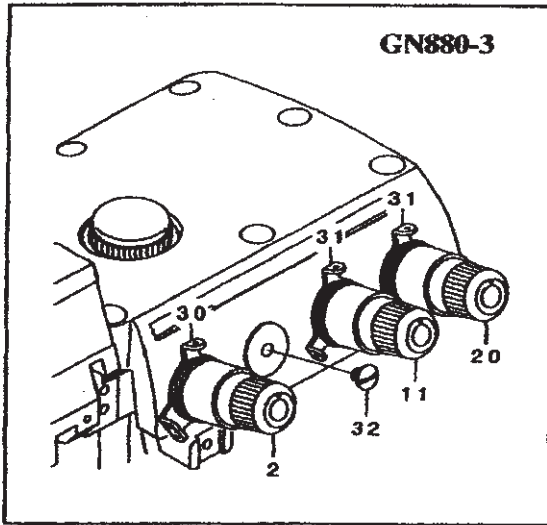

序号 REF.NO	NOTE	件号 PART NO.	零件名称	DESCRIPTION	数量 Qty
1		8038008	过线板	CENTER THREAD GUIDE	1
2		8038156	压线器组件(红)	TENSION SPRING ASM., RED	1
3		8285003	压线螺母(红)	THREAD TENSION KNOB, RED	(1)
4		8285508	压线压簧圈	TENSION SPRING BUSHING	(1)
5		8284709	机针线压线簧(红)	TENSION SPRING, RED	(1)
6		8285409	压线簧座	TENSION DISK PRESSER	(1)
7		8285607	压线簧座毡垫	THREAD TENSION SPRING FELT	(1)
8		8285706	压线板	THREAD TENSION DISK	(2)
9		8239402	压紧螺钉	TENSION POST	(1)
10		8285805	压线螺钉橡胶座	THREAD TENSION RUBBER	(1)
11		8038255	压线器组件(黄)	TENSION SPRING ASM., YELLOW	1
12		8285102	压线螺母(黄)	THREAD TENSION KNOB, YELLOW	(1)
13		8285508	压线压簧圈	TENSION SPRING BUSHING	(1)
14		8284808	弯针线压线簧(黄)	TENSION SPRING, YELLOW	(1)
15		8285409	压线簧座	TENSION DISK PRESSER	(1)
16		8285607	压线簧座毡垫	THREAD TENSION SPRING FELT	(1)
17		8285706	压线板	THREAD TENSION DISK	(2)
18		8239402	压紧螺钉	TENSION POST	(1)
19		8285805	压线螺钉橡胶座	THREAD TENSION RUBBER	(1)
20		8038354	压线器组件(蓝)	TENSION SPRING ASM., BLUE	1
21		8285201	压线螺母(蓝)	THREAD TENSION KNOB, BLUE	(1)
22		8285508	压线压簧圈	TENSION SPRING BUSHING	(1)
23		8284907	弯针线压线簧(蓝)	TENSION SPRING, BLUE	(1)
24		8285409	压线簧座	TENSION DISK PRESSER	(1)
25		8285607	压线簧座毡垫	THREAD TENSION SPRING FELT	(1)
26		8285706	压线板	THREAD TENSION DISK	(2)
27		8239402	压紧螺钉	TENSION POST	(1)
28		8285805	压线螺钉橡胶座	THREAD TENSION RUBBER	(1)
29		8108006	压线螺钉螺母	NUT	1
30		8039501	机针线过线板	THREAD GUIDE	1
31		8039600	弯针线过线板	THREAD GUIDE	1
32	02	8119300	机壳压线螺钉孔螺钉	SCREW	1
33	01	8039709	链线压线器座	THREAD GUIDE	1
34	01	8039808	链线压线螺钉	TENSION POST	1
35	01	8039303	压线板	THREAD TENSION DISK	2
36	01	8039204	压线簧座毡垫	THREAD TENSION FELT	1
37	01	8039907	链线压线簧	TENSION SPRING	1
38	01	8038701	压线压簧圈	ROTATING STOPPER	1
39	01	8040004	链线压线螺母	NUT	1
40	01	8110705	链线压夹线螺钉垫圈	THREAD TENSION COLLAR	1

NOTE

01...GN880-5 用

01...FOR GN880-5

02...GN880-3 用

02...FOR GN880-3

1. 油泵部件

1. LUBRIATION MECHANISM COMPONENTS

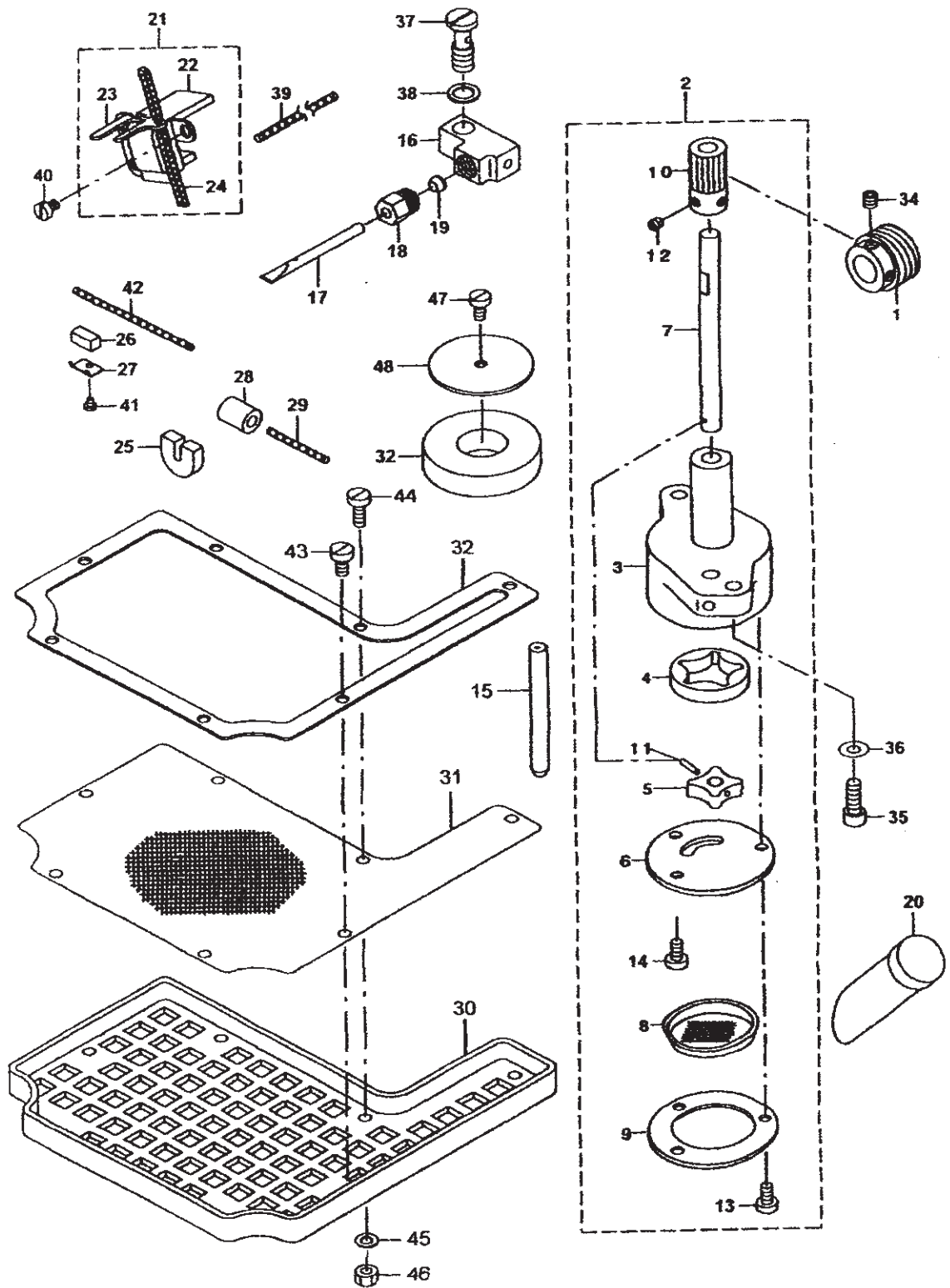

序号 REFNO	NOTE	件号 PART NO.	零件名称	DESCRIPTION	数量 Qty
1		8041507	油泵蜗杆	WORM	1
2		8041663	油泵体总成	OIL PUMP COMPL.	1
3		8041665	油泵体组件	OIL PUMP ASM.	(1)
4		8041804	油泵体外转子	OIL PUMP GEAR OUTER RING	(1)
5		8041903	油泵体内转子	OIL PUMP GEAR INNER RING	(1)
6		8042000	油泵盖	OIL PUMP COVER	(1)
7		8042109	油泵轴	OIL PUMP SHAFT	(1)
8		8042307	油泵滤油网	OIL PUMP NET	(1)
9		8042406	油泵滤油网压板	OIL PUMP NET PRESSER	(1)
10		8042505	油泵蜗轮	WORM GEAR	(1)
11		8101001	油泵内转子销	PIN	(1)
12		SM-8040412-TP	油泵蜗轮紧定螺钉 M4 L=4	SET SCREW M4 L=4	(2)
13		SM-6040800-SP	油泵滤油网压板螺钉	SCREW	(3)
14		SM-6040800-SP	油泵压板螺钉	SCREW	(1)
15		8042604	分油器油管	OILING EXIT PIPE	1
16		8042752	分油器组件	OILING EXIT SUPPORT COMPL.	1
17		8042802	分油器出油管	OILING EXIT	1
18		8042901	油管接头螺母	OILING EXIT JOINT A	1
19		8043008	油管接头螺母密封垫	OILING EXIT JOINT B	1
20		8043107	油标位	OIL GAUGE	1
21		8043255	针杆驱动曲柄销供油毛毡组件	OIL FELT ASM.	1
22		8043206	针杆驱动曲柄销供油毛毡	OIL FELT	(1)
23		8043305	针杆驱动曲柄销供油毛毡压板	OIL FELT PRESSER	(1)
24		CQ-2000000-OO	针杆上轴套油线	OIL WICK	(0.11)
25		8043404	针杆下轴套油毡	RETURNING OIL FILTER	1
26		8043602	上弯针导杆油毡	OIL FELT	1
27		8043701	上弯针导杆油毡压板	UPPER LOOPER OIL FELT	1
28		8043800	上弯针导杆销供油线套	OIL SUPPLY BUSH	1
29		CQ-2520000-OO	上弯针导杆销供油线	OIL WICK	0.03
30	*	8044014	油盘过滤盘	OIL RESERVOIR FILTER BASE	1
31	*	8044113	油盘过滤网	OIL RESERVOIR FILTER	1
32	*	8044212	油盘过滤网压板	FILTER PRESSER PLATE	1
33		8044303	油盘磁铁	MAGNET	1
34		SM-8040412-TP	油泵蜗杆紧定螺钉 M5 L=5	SCREW M5 L=5	2
35		SM-6051402-TP	油泵组件螺钉 MSX0.8 L=14	SCREW MSX0.8 L=14	2
36		WP-0531000-SD	油泵组件螺钉垫圈 M5	WASHER M5	2
37		8113501	油管接头螺栓 (M10)	SCREW	1
38		8103601	油管接头螺栓垫圈	GASKET	1
39		CQ-3030000-OO	针杆连杆销油线	OIL WICK	0.12
40		8118104	针杆连杆销油线螺钉	SCREW	3
41		SS-7060310-SP	上弯针导杆油毡压板螺钉 3/32-56 L=3	SCREW 3/32 - 56 L=3	1
42		CQ-2520000-OO	上弯针导杆销供油线	OIL WICK	0.06
43		SM-6040800-SP	油盘过滤盘螺钉	SCREW	2
44		SM-6041000-SP	油盘过滤网压板螺钉 M4 L=10	SCREW M4 L=10	5
45		8110101	油盘过滤网压板垫圈	WASHER	5
46		NM-6040003-SD	油盘过滤网压板螺母 M4	NUT M4	5
47		SM-6040800-SP	油盘磁铁螺钉	SCREW	1
48		8110507	油盘磁铁垫圈	WASHER	1

12. 上刀部件

12. KNIFE COMPONENTS

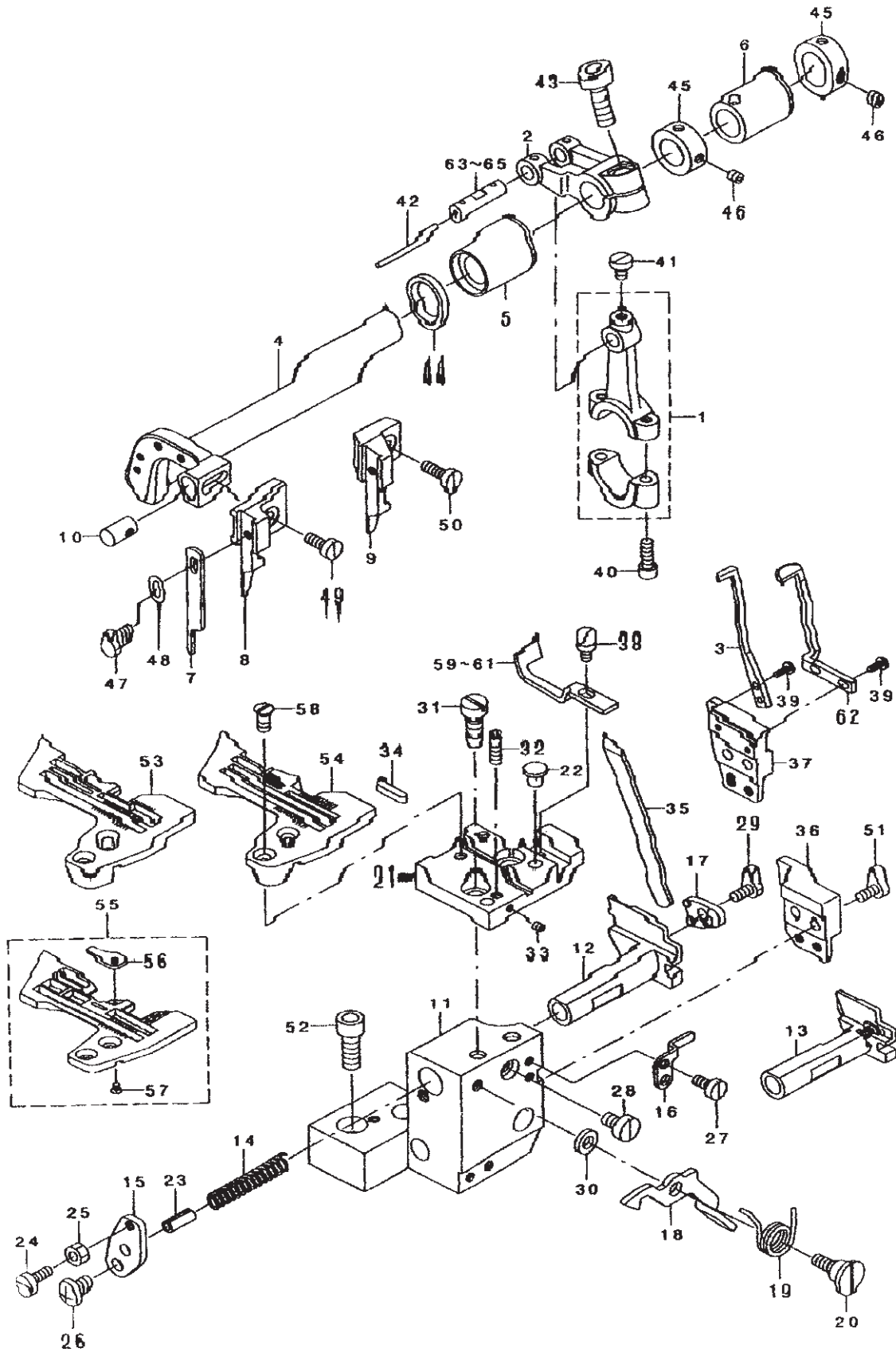

序号 REFNO	NOTE	件号 PART NO.	零件名称	DESCRIPTION	数量 Qty
1		8045003	上刀连杆	UPPER KNIFE ROD	1
2		8045102	上刀摇杆	UPPER KNIFE FORK ARM	1
3	02	8084705	五线护针	CHAIN LOOPER NEEDLE GUARD	1
4		8045201	上刀轴	KNIFE DRIVING ARM SHAFT	1
5		8045300	上刀轴左轴套	BUSHING, FRONT	1
6		8013001	上刀轴右轴套	BUSHING, REAR	1
7		8045508	上刀	KNIFE	1
8	01	8045607	三四线上刀托	UPPER KNIFE SUPPORT	1
9	02	8045706	五线上刀托	UPPER KNIFE SUPPORT	1
10		8045805	上刀托固定销	UPPER KNIFE GUIDE SHAFT	1
11		8045904	下刀架座	LOWER KNIFE BRACKET	1
12	01	8046001	三四线下刀架	LOWER KNIFE SLIDE STUD	1
13	02	8046100	五线下刀架	LOWER KNIFE SLIDE STUD	1
14		8046209	下刀压簧	SPRING	1
15		8046308	下刀压簧压板	STOPPER PLATE	1
16		8046407	下刀架限位板	ROTAING STOPPER	1
17		8046605	下刀压板	LOWER KNIFE HOLDER	1
18		8046902	缝台锁紧钩	LEVER	1
19		8047009	缝台锁紧钩扭簧	SPRING	1
20		8047108	缝台锁紧钩轴位螺钉	HINGE SCREW	1
21		8047207	针板垫块	THROAT PLATE BASE	1
22		8047306	针杆垫块防震垫	RUBBER PLUG A	2
23		8101605	下刀压簧导销	GUIDE PIN	1
24		SM-6041000-SP	缝台限位螺钉 M4 L=10	SCREW M4 L=10	1
25		NM-6040003-SD	缝台限位螺母 M4	NUT M4	1
26		SM-4050855-SP	下刀压簧压板螺钉	SCREW	1
27		SM-6040800-SP	下刀架限位板螺钉	SCREW	2
28		SM-6050800-SP	三四线下刀架螺钉 M5 L=8	SCREW M5 L=8	1
29		SM-9040800-SP	下刀螺钉	SCREW	1
30		8110804	缝台锁紧钩垫圈	WASHER	1
31		8120308	针板垫块螺钉	SCREW	2
32		SM-8041012-TP	缝台锁紧钩限位螺钉 M4 L=10	SCREW M4 L=10	1
33		SM-8030312-TP	缝台锁紧钩限位紧定螺钉 M3 L=3	SCREW M3 L=3	1
34		8047405	针板定位键	THROAT PLATE POSITIONING KEY	1
35		8047504	下刀	LOWER KNIFE	1
36	01	8046704	三四线护针架	NEEDLE GUARD HOLDER	1
37	02	8046803	五线护针架	NEEDLE GUARD HOLDER	1
38	*	SS-3090610-SP	链条前护针螺钉 9/64-40 L=6	SCREW 9/64 - 40 L=6	1
39	02	8116009	链条后护针螺钉	SCREW	4
40		SM-6041202-TP	上刀连杆螺钉 M4X0.7 L=12	SCREW M4X0.7 L=12	2
41		SM-6040600-SP	上刀连杆销紧定螺钉 M4 L=6	SCREW M4 L=6	1
42		CQ-2000000-OO	上刀连杆销油芯	OIL WICK	0.05
43		SM-6061602-TP	上刀摇杆螺钉 M6 L=16	SCREW M6 L=16	1
44		8105606	上刀轴油封	OIL SEAL	1
45		8100409	上刀轴垫圈	THRUST COLLAR	1
46		SM-8040412-TP	上刀轴垫圈紧定螺钉 M4 L=4	SET SCREW M4 L=4	4
47		SS-9090813-TP	上刀托螺栓 9/64-40 L=8	SCREW 9/64 - 40 L=8	1
48		WP-0370316-SD	上刀垫圈 3.7X8X0.3	WASHER 3.7X8X0.3	1
49	01	SM-6041000-SP	上刀托螺钉 M4 L=10	SCREW M4 L=10	1
50	02	SM-6041200-SP	上刀托螺钉 M4 L=12	SCREW M4 L=12	1
51		SM-6040800-SP	护针架螺钉	SCREW	2
52		SM-6061802-TP	下刀架座螺钉 M6 L=18	SCREW M6 L=18	2
53	03	R4200-LOE-EOO	针板 (3E-OE4-40H)	THROAT PLATE	1
54	04	R4305-LOE-EOO	针板 (4 线)	THROAT PLATE	1
55	02	R4508-LOE-GOO	针板 (5E-DE4-40H)	THROAT PLATE	1
56	02	8085009	小针板	THROAT PLATE CLAW	(1)
57	02	SS-1060210-TP	小针板螺钉 3/32-56 L=2.2	SCREW 3/32 - 56 L=2.2	(1)
58		8116504	针板螺钉	SCREW	2
59	03	8084101	三线护针	NEEDLE GUARD	1
60	04	8084200	四线护针	NEEDLE GUARD	1
61	02	8084408	链条前护针	CHAIN LOOPER NEEDLE GUARD	1
62	01	8084507	链条后护针	CHAIN LOOPER NEEDLE GUARD	1
63	05	8016202	上刀连杆销 A	CRANK PIN A	1
64	05	8016400	上刀连杆销 B	CRANK PIN B	1
65	05	8016509	上刀连杆销 C	CRANK PIN C	1

NOTE

01....GN880-3, GN880-4 用
02....GN880-5 用
03....GN880-3 用
04....GN880-4 用
05....另件选配件

01....FOR GN880-3, FOR GN880-4
02....FOR GN880-5
03....FOR GN880-3
04....FOR GN880-4
05....FOR SELECTIVE PART

13. 机架台板部件 (桌上式)

13. SEMI-SUNKEN TYPE TABLE COMPONENTS

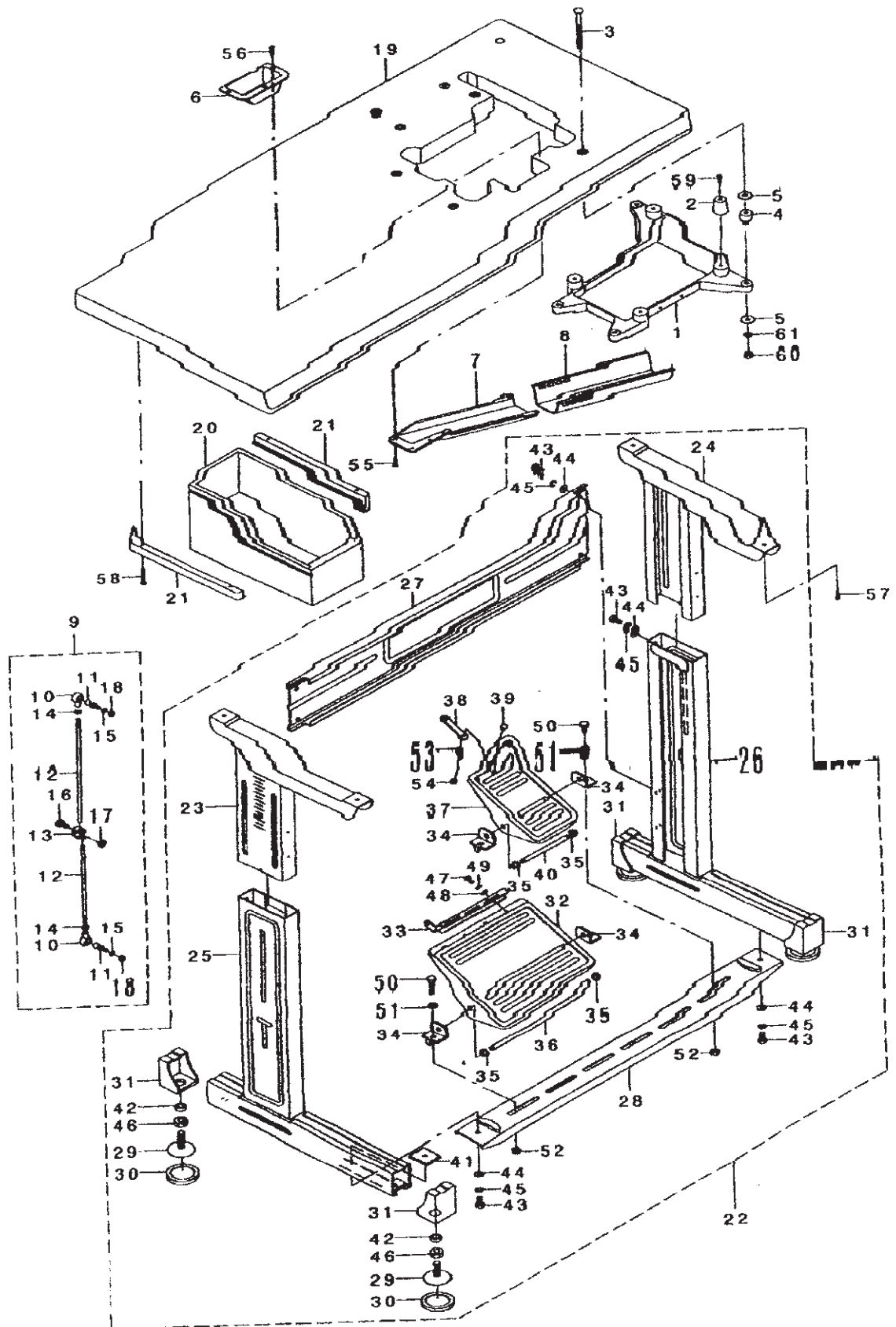

序号 REF.NO	NOTE	件号 PART NO.	零件名称	DESCRIPTION	数量 Qty
1		8048007	机头托盘	FRAME SUPPORT PLATE ASM.	1
2		8048106	机头防震垫	RUBBER CUSHION	4
3		8048205	机头托盘方颈螺钉A	BOLT A	4
4		8047900	机头托盘防震垫	BOLT SPACER	4
5		8111307	机头托盘垫圈	WASHER	8
6		8049401	布屑槽口	CLOTH WASTE CHUTE INLET	1
7		8048502	布屑槽 (上)	CLOTH WASTE CHUTE, UPPER	1
8		8048601	布屑槽 (下)	CLOTH WASTE CHUTE, LOWER	1
9	01	8048759	拉杆组件	CONNECTING ROD JOINT ASM.	1
10		8048700	拉杆球接头座	CONNECTING ROD JOINT	(2)
11		8048807	拉杆球接头	CONNECTING ROD JOINT A	(2)
12		8048908	拉杆	CONNECTING ROD	(2)
13		8049005	拉杆夹头	CONNECTING BASE	(1)
14		8108808	拉杆球接头螺母	NUT	(2)
15		8112107	拉杆球接头弹簧垫圈	SPRING WASHER	(2)
16		8125307	拉杆夹头螺栓	BOLT	(1)
17		8109004	拉杆夹头螺母	NUT	(1)
18		8108008	拉杆螺母	NUT	(2)
19	01	8049104	台板	TABLE ASML (SEMI-SUNKEN)	1
20	01	8049203	抽斗	DRAWER	1
21	01	8049302	抽斗导轨	DRAWER SUPPORT	2
22	01	8050052	T型机架组件	T-STAND COMPL.	1
23		8050151	台板支架 (左)	UPPER STAND COMPL., LEFT	(1)
24		8050250	台板支架 (右)	UPPER STAND COMPL., RIGHT	(1)
25		8050557	机架脚架 (左)	LOWER STAND COMPL., LEFT	(1)
26		8050656	机架脚架 (右)	LOWER STAND COMPL., RIGHT	(1)
27		8051209	脚架后横档	SIDE STRUT	(1)
28		8051308	踏板横档	LOWER STRUT	(1)
29		8051456	机架调节座	ADJUSTING SCREW COMPL.	(4)
30		8051605	机架调节座橡胶套	BASE CAP	(4)
31		8051704	橡胶脚套	STAND BASE CAP	(4)
32		8051852	大踏板组件	PEDAL COMPL.	(1)
33		8052009	踏板调节板	PEDAL ADJUSTING PLATE	(1)
34		8052108	踏板支座	PEDAL SUPPORT	(4)
35		8052207	踏板轴套	BUSHING	(4)
36		8052306	大踏板轴	PEDAL SHAFT	(1)
37		8052405	小踏板	PRESSER LIFTING PEDAL	(1)
38		8052504	小踏板连接板	CHAIN HOOK	(1)
39		8052603	小踏板连接板螺栓	SCREW	(1)
40		8052702	小踏板轴	PEDAL SHAFT	(1)
41		8052801	踏板横档方螺母	NUT	(2)
42		8052900	机架调节座垫圈	COLLAR	(4)
43		8125307	机架螺栓	BOLT	(16)
44		8111109	机架垫圈	WASHER	(16)
45		8112206	机架弹簧垫圈	SPRING WASHER	(16)
46		8109301	机架调节座螺母	NUT	(4)
47		8124706	踏板调节板螺钉	SCREW	(2)
48		8110903	踏板调节板垫圈	WASHER	(2)
49		8112107	踏板调节板弹簧垫圈	SPRING WASHER	(2)
50		8125307	踏板支座架螺栓	BOLT	(4)
51		8111109	踏板支座架垫圈	WASHER	(8)
52		8109004	踏板支座架螺母	NUT	(4)
53		8112107	小踏板连接板弹簧垫圈	SPRING WASHER	(1)
54		8108808	小踏板连接板螺母	NUT	(1)
55		8126107	布屑槽 (上) 螺钉	SCREW	4
56	*	8126602	布屑槽口螺钉	SCREW	3
57	01	8126206	台板木螺钉	WOOD SCREW	4
58	01	8126503	抽斗导轨螺钉	SCREW	4
59		8113709	机头防震垫轴位螺钉	SCREW	4
60		8109004	机头托盘螺母	NUT	4
61		8112206	机头托盘弹簧垫圈	SPRING WASHER	4

NOTE

01... 不随机头出厂

01...EXCLUDED WHEN DELIVERING
HEAD ONLY.

14. 机架台板部件 (全沉式)

14. FULLY-SUNKEN TYPE TABLE COMPONENTS

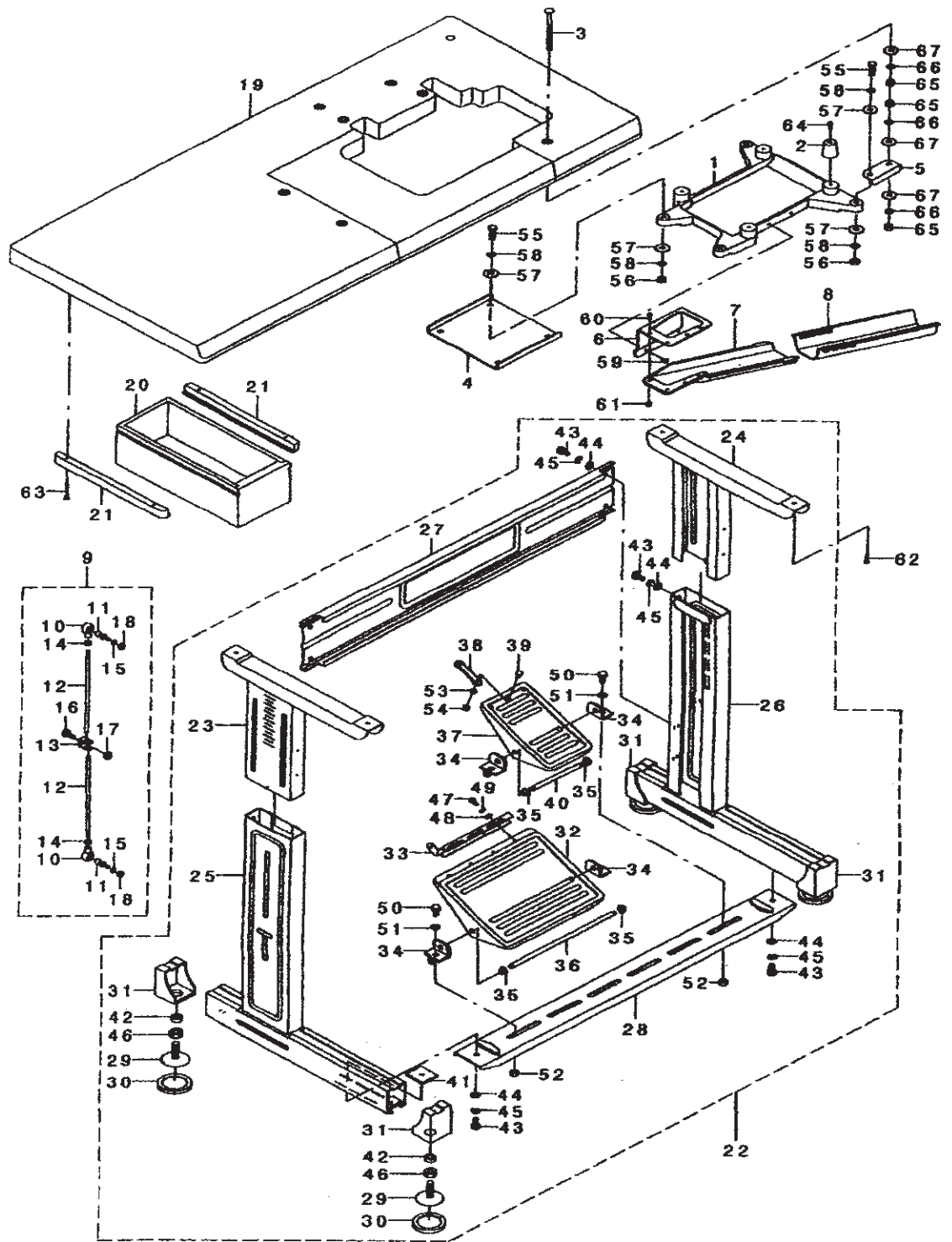

序号 REFNO	件号 NOTE	零件名称 PART NO.	DESCRIPTION	数量 Qty	
1		8048007	机头托盘	PRAME SUPPORT PLATE ASM.	1
2		8048106	机头防震垫	RUBBER CUSHION	4
3		8053205	机头托盘方颈螺栓B	BOLT B	4
4		8053304	机头托盘连接板A	AUXILIART PLATE A	1
5		8053403	机头托盘连接板B	AUXILIART PLATE B	1
6		8053502	集料槽限位板	SUPPORT PLATE	1
7		8048502	布屑槽 (上)	CLOTH WASTE CHUTE, UPPER	1
8		8048601	布屑槽 (下)	CLOTH WASTE CHUTE, LOWER	1
9	01	8048759	拉杆组件	CONNECTING ROD JOINT ASM.	1
10		8048700	拉杆球接头座	CONNECTING ROD JOINT	(2)
11		8048809	拉杆球接头	CONNECTING ROD JOINT A	(2)
12		8048908	拉杆	CONNECTING ROD	(2)
13		8049005	拉杆夹头	CONNECTING BASE	(1)
14		8108808	拉杆球接头螺母	NUT	(2)
15		8112107	拉杆球接头弹簧垫圈	SPRING WASHER	(2)
16		8125307	拉杆夹头螺栓	BOLT	(1)
17		8109004	拉杆夹头螺母	NUT	(1)
18		8108808	拉杆螺母	NUT	(2)
19	01	8053650	台板 (全沉式) 组件	TABLE ASM., FULLY-SUNKEN TYPE	1
20	01	8049203	抽斗	DRAWER	1
21	01	8049302	抽斗导轨	DRAWER SUPPORT	2
22	01	8050052	T型机架组件	T-STAND COMPL.	1
23		8050151	台板支架 (左)	UPPER STAND COMPL., LEFT	(1)
24		8050250	台板支架 (右)	UPPER STAND COMPL., RIGHT	(1)
25		8050557	机架脚架 (左)	LOWER STAND COMPL., LEFT	(1)
26		8050656	机架脚架 (右)	LOWER STAND COMPL., RIGHT	(1)
27		8051209	脚架后横档	SIDE STRUT	(1)
28		8051308	踏板横档	LOWER STRUT	(1)
29		8051456	机架调节座	ADJUSTING SCREW COMPL.	(4)
30		8051605	机架调节座橡胶套	BASE CAP	(4)
31		8051704	橡胶脚套	STAND BASE CAP	(4)
32		8051852	大踏板组件	PEDAL COMPL.	(1)
33		8052009	踏板调节板	PEDAL ADJUSTING PLATE	(1)
34		8052108	踏板支座	PEDAL SUPPORT	(4)
35		8052207	踏板轴套	BUSHING	(4)
36		8052306	大踏板轴	PEDAL SHAFT	(1)
37		8052405	小踏板	PRESSER LIFTING PEDAL	(1)
38		8052504	小踏板连接板	CHAIN HOOK	(1)
39		8052603	小踏板连接板螺栓	SCREW	(1)
40		8052702	小踏板轴	PEDAL SHAFT	(1)
41		8052801	踏板横档方螺母	NUT	(2)
42		8052900	机架调节座垫圈	COLLAR	(4)
43		8125307	机架螺栓	BOLT	(16)
44		8111109	机架垫圈	WASHER	(16)
45		8112206	机架弹簧垫圈	SPRING WASHER	(16)
46		8109301	机架调节座螺母	NUT	(4)
47		8124706	踏板调节板螺钉	SCREW	(2)
48		8110903	踏板调节板垫圈	WASHER	(2)
49		8112107	踏板调节板弹簧垫圈	SPRING WASHER	(2)
50		8125307	踏板支座架螺栓	BOLT	(4)
51		8111109	踏板支座架垫圈	WASHER	(8)
52		8109004	踏板支座架螺母	NUT	(4)
53		8112107	小踏板连接板弹簧垫圈	SPRING WASHER	(1)
54		8108808	小踏板连接板螺母	NUT	(1)
55		8125406	机头托盘连接板螺栓	BOLT	3
56		8109004	机头托盘连接板螺母	NUT	3
57		8111307	机头托盘连接板垫圈	WASHER	6
58		8112206	机头托盘连接板螺栓弹簧垫圈	SPRING WASHER	6
59		SM-4050855-SP	布屑槽压板螺钉	SCREW	2
60		SM-6041200-SP	布屑槽 (上) 螺钉 M4 L=12	SCREW M4 L=12	4
61		8108303	布屑槽 (上) 螺母	NUT	4
62	01	8126206	台板木螺钉	WOOD SCREW	4
63	01	8126503	抽斗导轨螺钉	SCREW	4
64		8113709	机头防震垫圈轴位螺钉	SCREW	4
65		8109004	机头托盘螺母	NUT	12
66		8112206	机头托盘弹簧垫圈	SPRING WASHER	12
67		8111307	机头托盘垫圈	WASHER	12

NOTE 01... 不随机头出厂

01...EXCLUDER WHEN DELIVERING HEAD ONLY.

15. 线架部件

15. THREAD STAND COMPONENTS

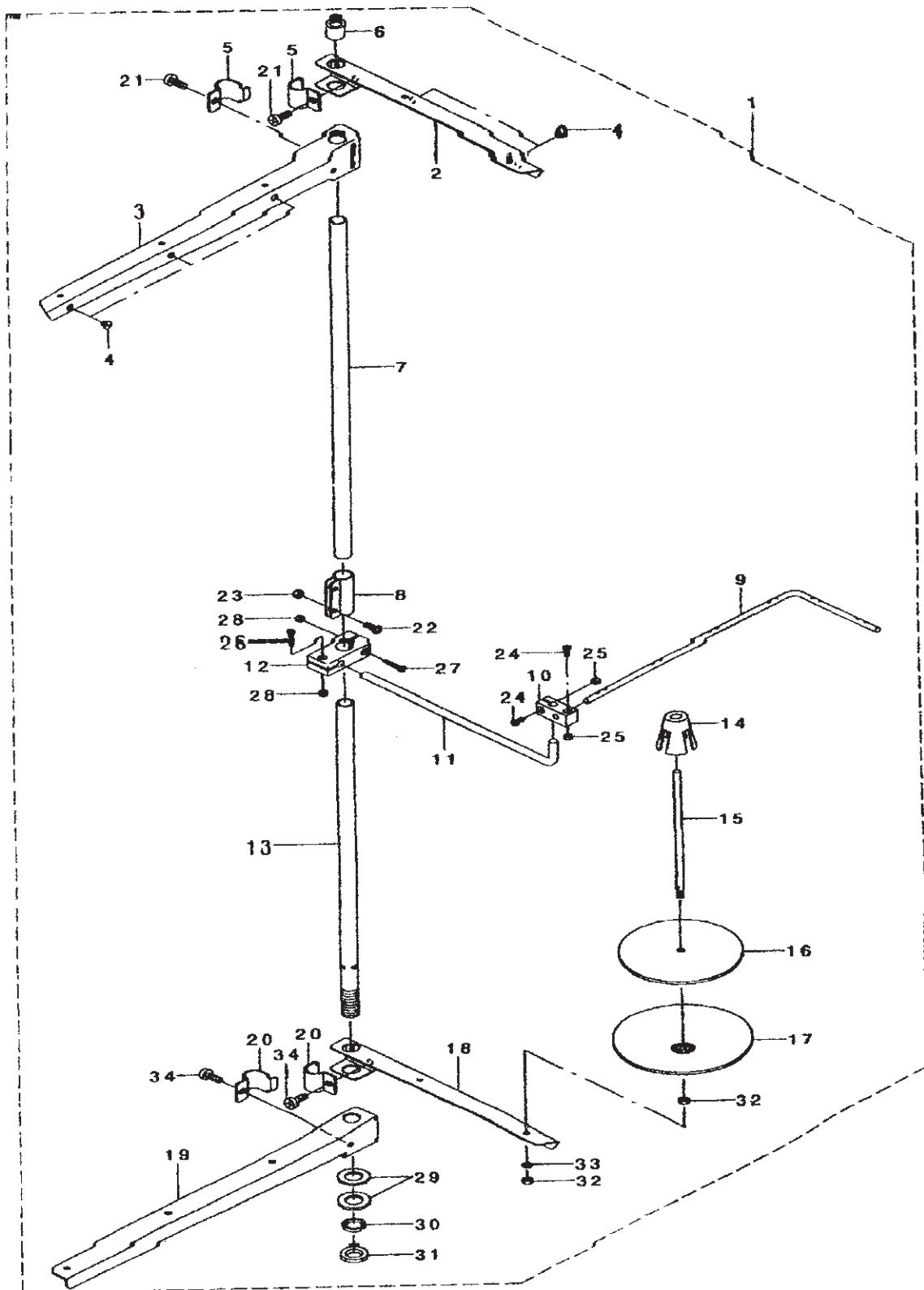

序号 REFNO	件号 NOTE	零件名称 PART NO.	DESCRIPTION	数量 Qty
1		3060150	线架组件	1
2		8330507	二线过线板	(1)
3		8061703	三线过线板	(1)
4		8331208	过线圈	(5)
5		8330705	夹紧圈	(2)
6		8331406	立柱闷头	(1)
7		8330408	立柱(上)	(1)
8		8331307	立柱接头	(1)
9		8060705	中过线杆	(1)
10		8060804	中过线杆夹头	(1)
11		8060903	中过线接杆	(1)
12		8061000	中过线接杆夹头	(1)
13		8330309	立柱(下)	(1)
14		8331109	线固定心节	(5)
15		8331000	线柱	(5)
16		8330903	线盘垫	(5)
17		8330804	线盘	(5)
18		8330507	二线线架盘	(1)
19		8061703	三线线架盘	(1)
20		8330705	夹紧圈	(2)
21	*	SM-6061610-SC	过线板螺钉	(2)
22		SM-4051405-SE	立柱接头螺钉	(2)
23		NM-6050001-SE	立柱接头螺母	(2)
24		8118302	中过线杆夹头螺钉	(2)
25		8108303	中过线杆夹头螺钉螺母	(2)
26		8118401	中过线接杆夹头螺钉A	(1)
27		8118500	中过线接杆夹头螺钉B	(1)
28		8108303	中过线接杆夹头螺母	(2)
29		WP-1702600-SO	立柱(下)垫圈	(2)
30		WS-1643202-KR	波形垫圈	(1)
31		NM-6160511-SE	立柱(下)细牙扁螺母	(1)
32		NM-6050001-SE	线柱方螺母	(5)
33		WS-0510002-KN	线柱弹簧垫圈	(5)
34		SM-6061610-SC	线架架螺钉	(2)

16. 机针冷却部件

16. NEEDLE COOLER COMPONENTS

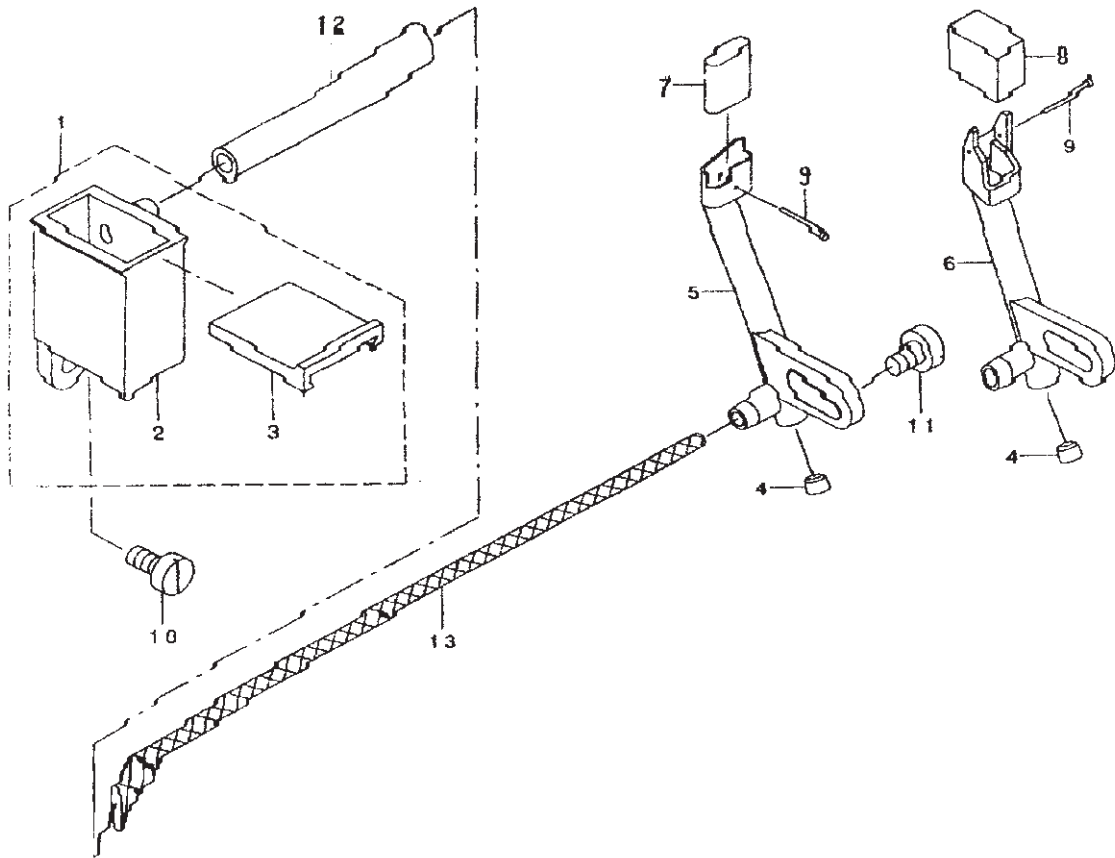

序号 REFNO.	NOTE	件号 PART NO.	零件名称	DESCRIPTION	数量 Qty
1		8058550	针尖冷却油盒组件	NEEDLE COOLER TANK ASM.	1
2		8058501	针尖冷却油盒体	NEEDLE COOLER TANK	(1)
3		8058600	针尖冷却油盒盖	TANK COVER	(1)
4		8106505	针尖冷却座闷塞	PLUG	1
5	01	8058709	三四线针尖冷却座	NEEDLE COOLER UNIT (OVER)	1
6	02	8058804	五线针尖冷却座	NEEDLE COOLER UNIT (INTER)	1
7	01	8059103	三四线针尖冷却毛毡	NEEDLE COOLER FELT	1
8	02	8058907	五线针尖冷却毛毡	NEEDLE COOLER FELT	1
9		8059004	针尖冷却毛毡销	NEEDLE COOLER FELT PRESSER	1
10		SM-6040800-SP	针尖冷却油盒螺钉	SCREW	1
11		SM-6040600-SP	针尖冷却座螺钉 M4 L=6	SCREW M4 L=6	2
12		8102603	针尖冷却毛毡供油线管	NEEDLE COOLER PIPE	0.05
13		8102405	针尖冷却毛毡供油线	NEEDLE COOLER OIL WICK	0.15
NOTE			01...GN880-3, 880-4 用 02...GN880-5 用	01...FOR GN880-3, 880-4 02...FOR GN880-5	

17. 附件

17. ACCESSORIE PART COMPONENTS

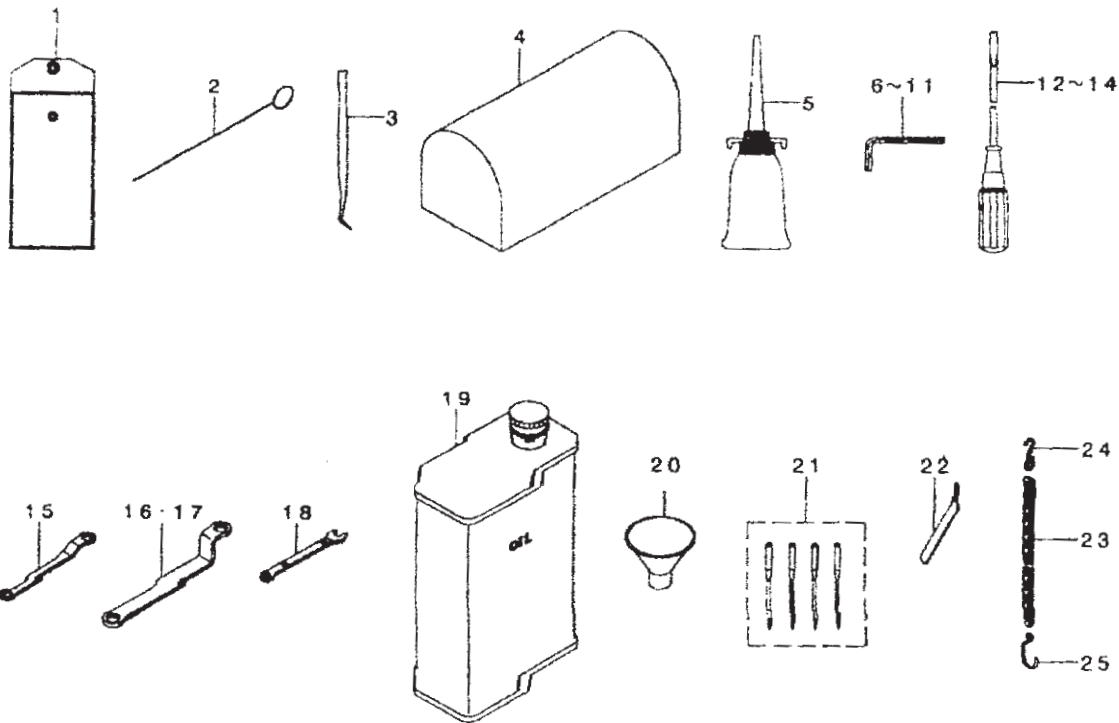

序号 REFNO	NOTE	件号 PART NO.	零件名称	DESCRIPTION	数量 Qty
1		8055002	附件袋	ACCESSORY PACK	1
2		8055101	穿线钩	THREADER	1
3		8055200	弯头镊钳	TWEEZERS	1
4		8055309	机头套	VINYL HEAD COVER	1
5		8055408	小油壶	OILER	1
6		8056801	六角扳手 (1.6)	HEXAGONAL WRENCH, 1.5	1
7		8055606	六角扳手 (2.0)	HEXAGONAL WRENCH, 2.0	1
8		8055705	六角扳手 (2.5)	HEXAGONAL WRENCH, 2.5	1
9		8055804	六角扳手 (3.0)	HEXAGONAL WRENCH, 3.0	1
10		8055903	六角扳手 (4.0)	HEXAGONAL WRENCH, 4.0	1
11		8056000	六角扳手 (5.0)	HEXAGONAL WRENCH, 5.0	1
12		8056109	一字槽螺钉旋具 (小)	SCREWDRIVER, SMALL	1
13		8056208	一字槽螺钉旋具 (长)	SCREWDRIVER, MIDDLE	1
14		8056307	一字槽螺钉旋具 (短)	SCREWDRIVER, LARGE	1
15		8056505	梅花扳手 (7x7)	SPECTALE WRENCH, 7x7	1
16		8056406	梅花扳手 (5.5)	SPECTALE WRENCH, 5.5	1
17		8056703	梅花扳手 (9.0)	SPECTALE WRENCH, 9.0	1
18		8057701	六角扳手 (5x6)	WRENCH, 5x6	1
19		8057107	油桶 (900CC)	OIL	1
20		8057206	漏斗	FUNNEL	1
21		MDC270B1104	机针 (DCx27-#11)	NEDDLE DCX27#11-4EA	1
22		8047504	下刀	LOWER KNIFE	1
23		8057404	链条	CHAIN	1
24		8057503	链条钩 (小)	S-SHAPED METAL FITTING, SMALL	1
25		8057602	链条钩 (大)	S-SHAPED METAL FITTING, LARGE	1