

# ARTISAN®

**Model 518**  
**Single Needle, Needle Feed Lockstitch**  
**High Speed Sewing Machine**  
**With Automatic Lubrication**

## **Instruction Manual** **&** **Spare Parts List**

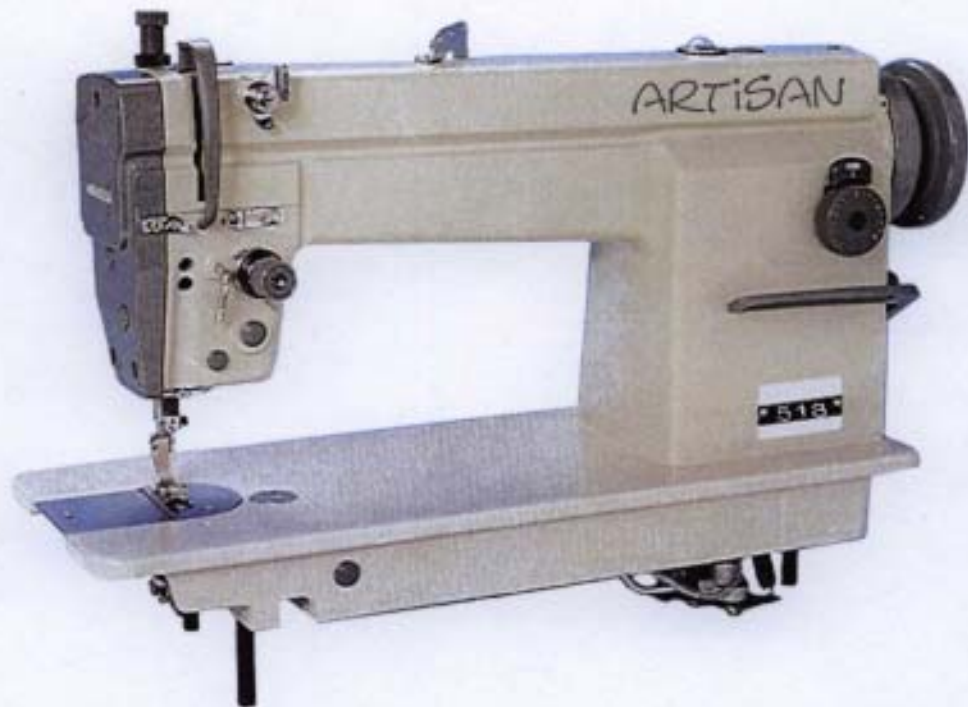

## PRECAUTIONS BEFORE STARTING OPERATION

### ① Safety Precautions

1. When turning the power on, keep your hands and fingers away from the area around/under the needle and the area around the pulley.
2. Power must be turned off when the machine is not in use, or when the operator leaves his/her seat.
3. Power must be turned off before tilting the machine head, installing or removing the "V" belt, adjusting the machine, or when replacing.
4. Avoid placing fingers, hairs, bars etc., near the pulley, "V" belt, bobbin winder pulley, or motor when the machine is in operation. Injury could result.
5. Do not insert fingers into the thread take-up cover, under/around the needle, or pulley when the machine is in operation.
6. If a belt cover, finger guard, and/or eye guard are installed, do not operate the machine without these safety devices.

### ② Precautions before Starting Operation

1. If the machine's oil pan has an oil sump, never operate the machine before filling it.
2. If the machine is lubricated by a drop oiler, never operate the machine before lubricating.
3. When a new sewing machine is first turned on, verify the rotational direction of the pulley with the power on.  
(The pulley should rotate counterclockwise when viewed from the pulley.)
4. Verify the voltage and (single or three) phase with those given on the machine nameplate.

### ③ Precautions for Operating Conditions

1. Avoid using the machine at abnormally high temperature (35°C or higher) or low temperatures (5°C or lower). Otherwise, machine failure may result.
2. Avoid using the machine in dusty conditions.

## 1 Lubrication—1

Before starting to operate pour oil up to the position (A) of oil tank. During operation check the oil volume periodically, and in case where oil level is below the position (B), replenish oil up to the position (A).

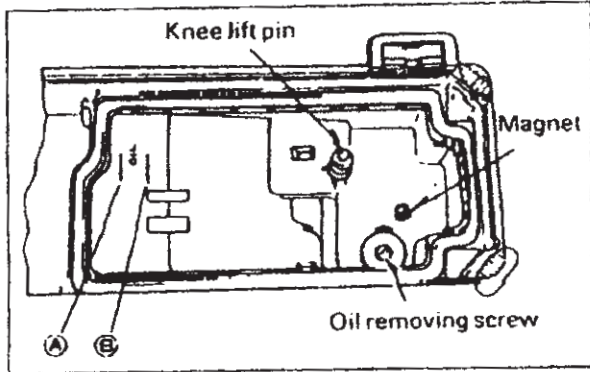

## 3 Condition of oil lubrication

While operating the machine, check the condition of oil lubrication through the oil check window.

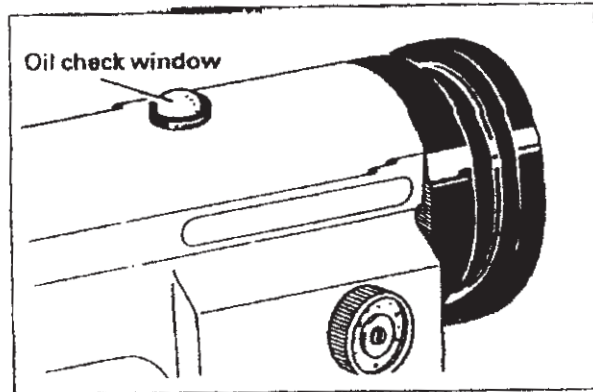

## 4 Adjustment of hook lubrication

Adjustment is made by rotating screw (A).

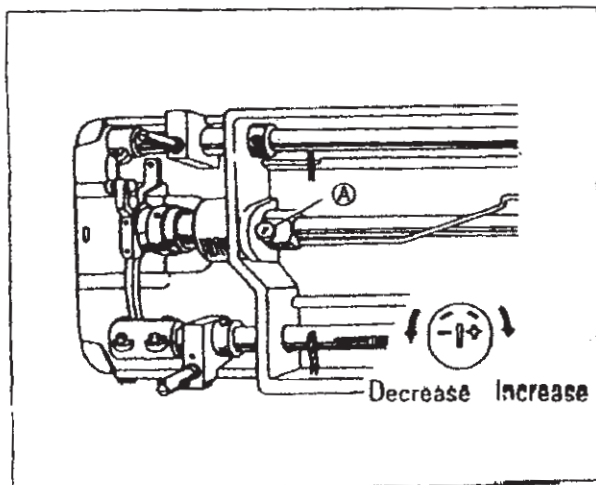

## 2 Lubrication—2

When a new sewing machine is first operated, or when a sewing machine left out of use for long period of time is operated, it will be necessary to oil through the oil filling holes after removing the rubber plugs shown below.

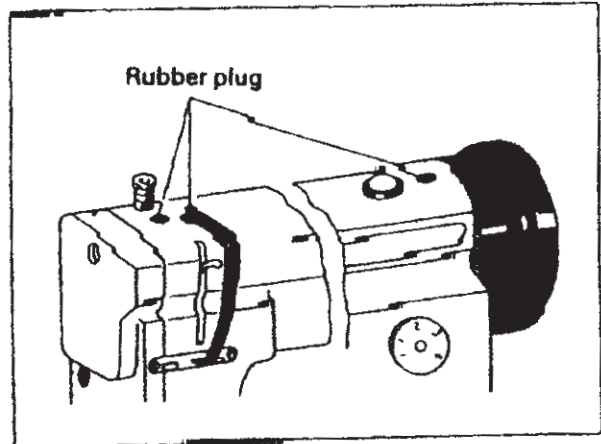

## 5 Adjustment of oil pump

The standard adjustment is as shown below. (0.5 ~ 1.0 mm). If oil splash is not observed through the oil check window, reduce this gap.

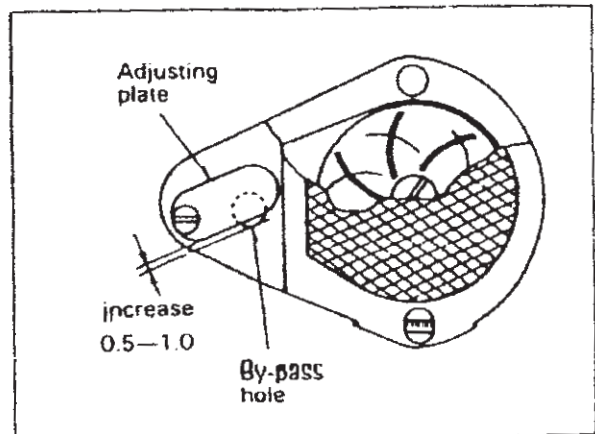

## 6 Periodical cleaning (Machine)

\* Remove the throat plate and clean the lead dog. Assembling is to be made by screwing in the screw by 2—3 rotations by hand at first, then tightening them evenly by use of a long size screw driver.

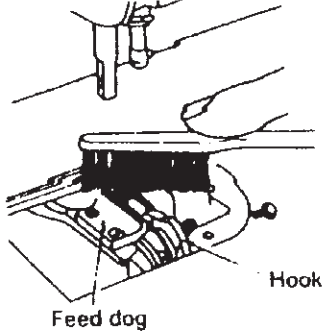

\* Lay down the machine head and clean the hook and inner bobbin case.

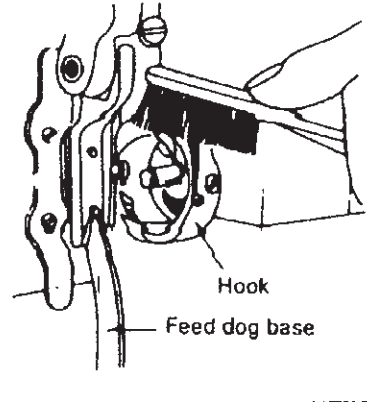

\* Lay down the machine head and clean the oil pump screen.

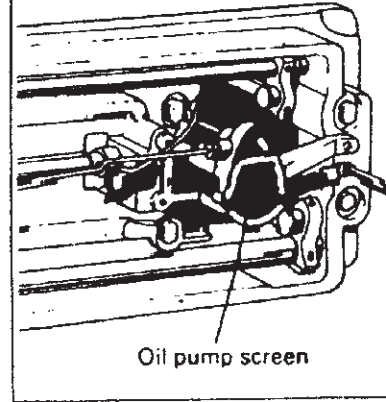

### (Maintenance of motor)

Remove dust from the motor filter every one or two month. (If operation is continued with the filter clogged with lint or dust, the motor might overheat)

(Control box) Remove dust from the connector (If the connector covered with dust, machine might misoperated.)

## 7 Installation of belt covers

(Machine head) . . . . . Be sure to install the belt cover for safety. Refer the instruction manual in the accessory box.

(Motor) . . . . . Be sure to install the belt cover for safety.

## 8 How to attach needle

Note: Before making the following adjustment, be sure to switch off the power source.

Insert the needle upto the bottom of needle clamp and tighten the screw keeping the long groove side of needle forward the left.

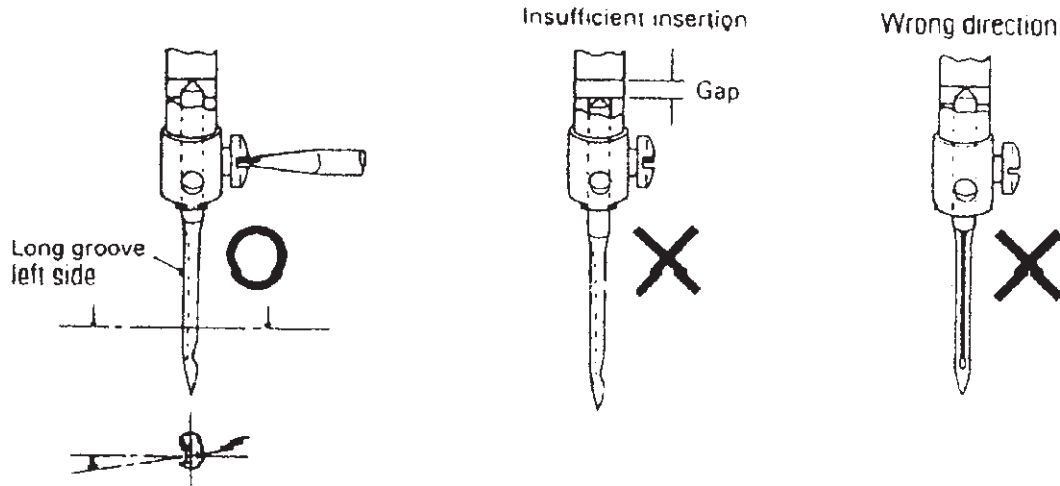

Note: If snapping of thread occurs during back sewing with polyester threads, it may be avoided by fitting the needle with the long groove shifted to the front side.

Use DBx1, DAx1 or needle. According to fabric & thread, please choose the size of needle as follows.

Size of Needle	No. of Thread	Fabric
#9	#100 ~ #80	Extra thin fabric such as de Chin, Georgette, Organdy, etc.
#11	#80 ~ #60	Thin fabrics such as Silk, Calico, Poplin, etc.
#14	#60 ~ #50	General fabrics such as Cotton, Wooden fabric, etc.
#16	#50 ~ #30	Thick Calico, Thick wooden fabric, Water proof cloth, thin leather, etc.

## 9 Threading

Raise the thread take-up lever to its highest position and thread the upper thread in the following order.

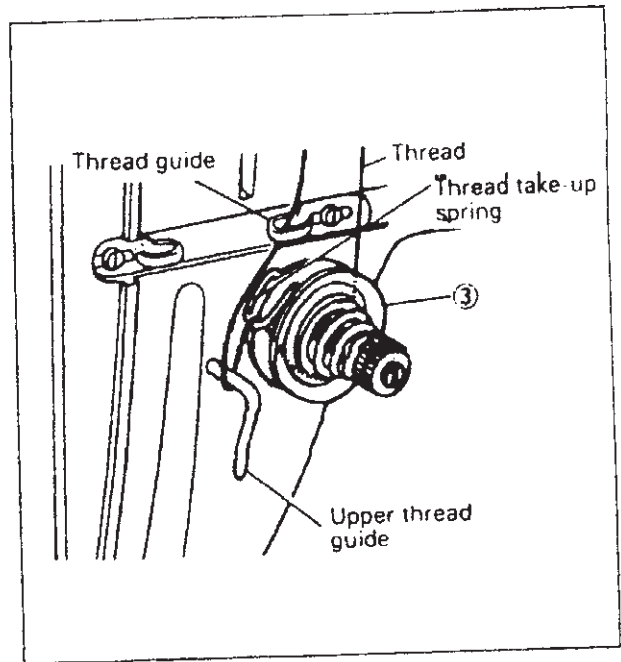
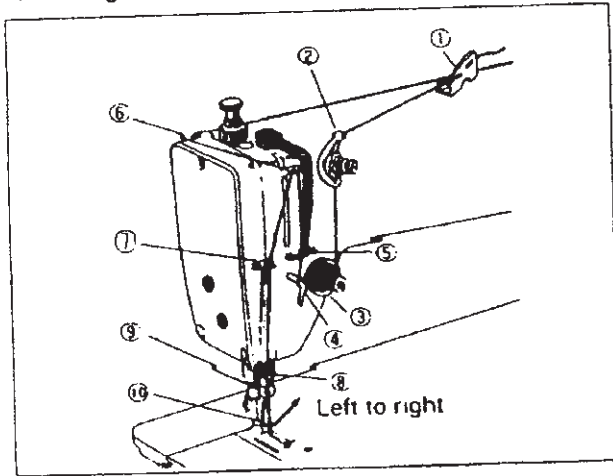

## 10 Adjusting of stitch length & reverse lever

Note: For desired stitch length, push the reverse lever downward and adjust by stitch length adjusting dial.

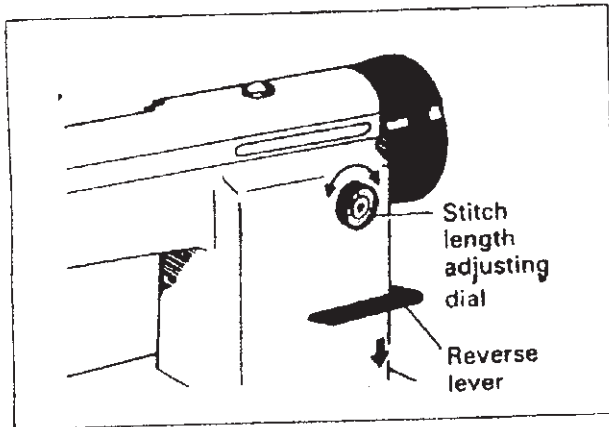

## 11 Adjusting of thread guide

Adjusting the thread guide as shown below.

	1	2	3
Thread guide position	Left	Middle	Right
Materials	Heavy	Medium	Light
Thread (Ref.)	Plyester #30 Cotton #30 Vinylon #30	Plyester #50 ~ 60 Cotton #50 ~ 80 Vinylon #50 ~ 80	Polyester #50 ~ 80

## 12 Adjusting of pressure of presser foot

Pressure of the presser foot can be adjusted by turning the pressure regulating thumb screw.

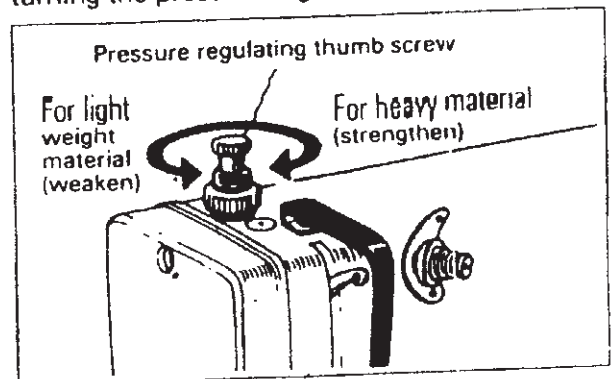

### 13 Adjusting of thread tension

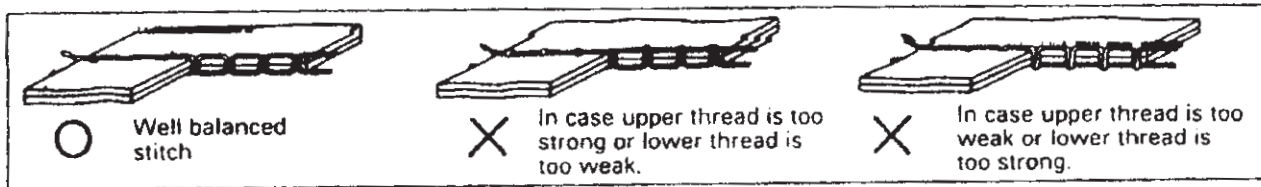

### 14 Upper thread tension:

1. Upper thread tension can be adjusted by tension regulating thumb nut.
2. Upper thread is to be adjusted according to the lower thread tension.

For special fabric sewing with special thread, the desired tension can be obtained by adjusting the strength and operating range of thread take-up spring.

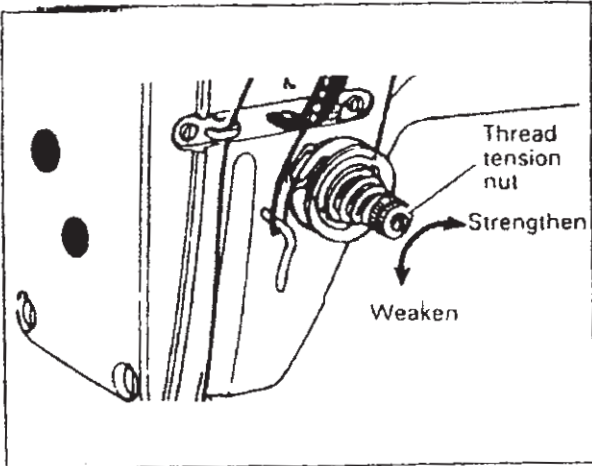

### 15 Lower thread tension

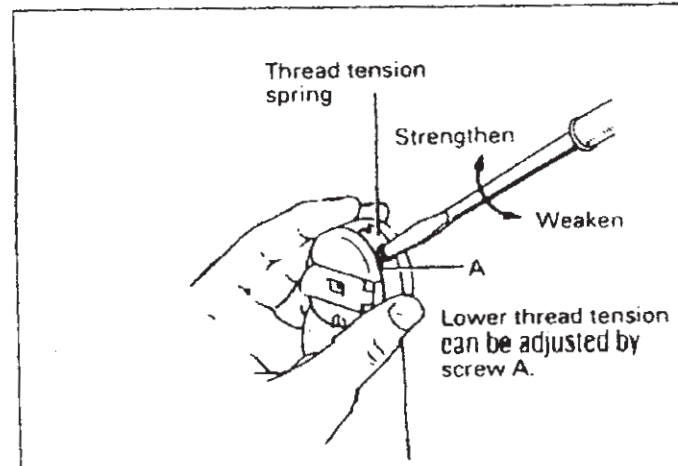

In the case of cotton thread #60, the thread tension can be checked as the following. Hold the end of pulled out thread and if the bobbin case fall slowly, the tension is proper.

### 16 Method of adjusting the thread tension disc

It is to be practiced according to the following procedure, as the open-timing for thread tension disc can be adjusted against the lift of the presser foot (within a range of 2—7 mm).

1. Loosen screw (A) after removing the rubber plug.
2. Move the thread loosening cam towards right or left.  
Right side position → hasten open-timing  
Left side position → delay open-timing
3. Thighen screw (A) after making sure of opening condition of the thread tension disc.

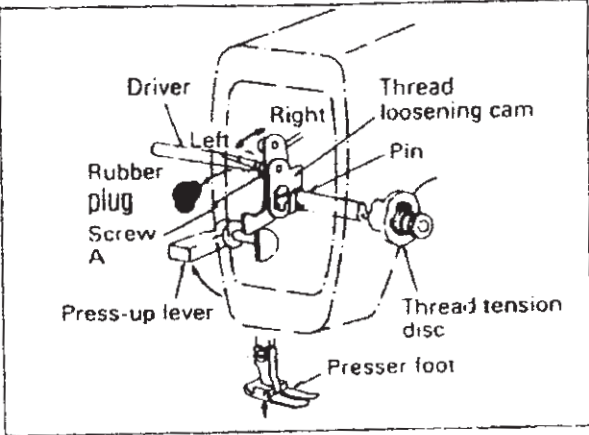

**17** How to wind the lower thread on the bobbin

- Adjustment ..... Strength of winding: Particularly in the case of nylon or polyester thread, it is desirable that the bobbin is wound loosely enough.
- ..... Uneven winding: In the case of uneven winding, adjust the thread guide slightly toward the less wound part of bobbin to obtain even winding.
- ..... Winding amount of thread: When the winding amount of thread is excessive, loosen the adjusting screw and tighten when insufficient.

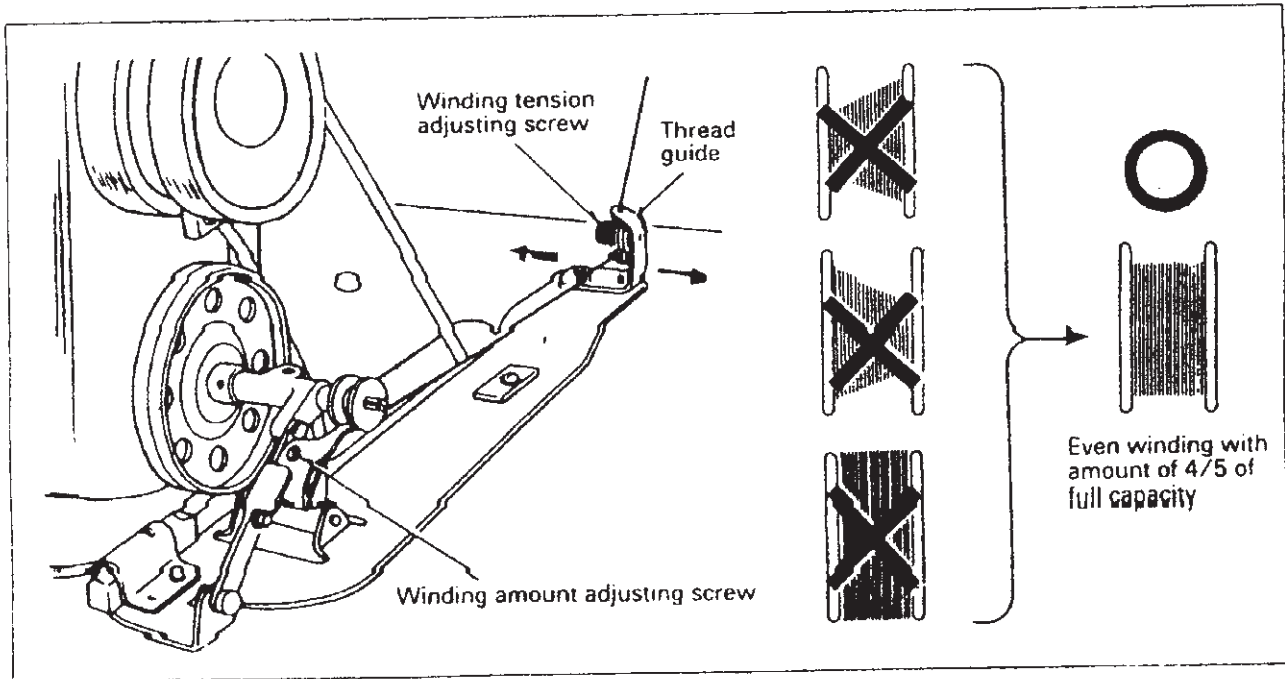



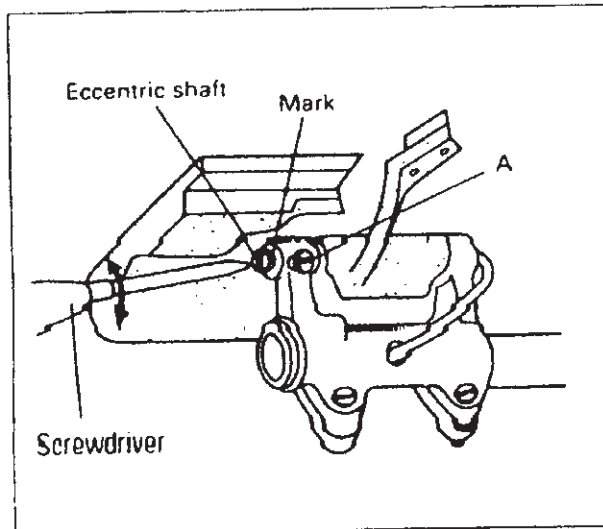



## 18 Adjustment of feed dog inclination



The feed dog is set horizontally. If necessary, adjust the inclination according to the sewn materials as follows:

- (1) Loosen two screws A .
- (2) Turn the eccentric shaft.
- (3) Tighten screw A .

Position of mark on the eccentric shaft	Feed dog
 Horizontal	 Standard
 Up	 Max. forward up
 Down	 Max. forward down

- When the eccentric shaft is set to "UP" position, puckering may be avoided and free loop is less like to occur.
- When the eccentric shaft is set to "DOWN" position, misalignment of fabrics is less likely to occur and yarn severance may be avoided.

## 19 Specification

Model	[REDACTED]	
Material weight	Light to medium	
Max. speed (spm) *Note 1	5000	
Max. stitch length	4 mm (5/32")	
Needle bar stroke	31.8 mm (1-1/4")	
Presser foot clearance	Knee lifter	11 mm (7/16")
	Hand	5 mm (13/64")
Needle type *Note 2	Organ	DBx1 #14
	Singer	SY1515 #14
	Schmetz	14: 25 Nm 90

- Note 1. Max speed should be 4500 spm for backtacking  
 2. Needle type (Organ needles are standard)



# 1. ARM BED AND IT'S ACCESSORIES

No.	Ref. No.	Description	Pcs.	Remarks
1	72T1-004C4	Rubber plug	6	Φ11.8
2	72T1-004C3	Rubber plug	2	Φ19
3	72T1-009	Rubber plug	5	Φ8.8
4	72T2-003	Set screw	1	
5	72T1-011	Rubber plug	2	Φ5.7
6	72T2-002	Thread take-up cover	1	
7	22T1-011	Set screw	1	
8	82T1-005	Thread guide	1	
9	82T1-006	Set screw	1	SM11/64"(4.37)×40
10	72T1-017	Set screw	8	
11	72T1-006E	Oil check window	1	
12	72T1-010	Rubber plug	1	Φ27
13	GB93-76	Spring washer	2	Washer 6
14	22T1-022	Leg	3	
15	72T1-014	Cloth guide plate	1	
16	72T1-013	Set screw	2	
17	22T1-003C6	Set screw	2	
18	72T1-008	Set screw	1	
19	22T1-014	Thread guide	1	
20	22T1-003C5	Thread guide	1	
21	30H1-007D2	Face plate gasket	1	
22	30H1-007D1	Face plate	1	
23	72T1-016	Set screw	3	
24	72T1-019	Set screw	2	
25	30H1-012	Needle plate	1	
26	22T1-021G1	Slide plate	1	
27	72T1-021G1	Slide plate spring	1	
28	22T1-021G3	Set screw	2	
29	82T1-007C4	Pre-tension thread guide	1	
30	82T1-007C3	Screw type tension stud	1	SM11/64"(4.37)×40
31	22T1-009E3	Disk for pre-tension	2	
32	82T1-007C2	Spring for pre-tension	1	
33	82T1-007C1	Nut for pre-tension	1	
34	22T1-012F11	O-ring	1	
35	22T1-012F8	Set screw	1	SM9/64"(3.57)×40/4
36	72T1-007F3	Thread tension regulating bushing	1	
37	22T1-012F6	Thread take-up spring	1	
38	22T1-012F1	Thread tension stud	1	
39	22T1-012F9	Thread tension releasing pin	1	
40	72T1-007F5	Thread tension disc	2	
41	72T1-007F2	Thread releasing disc	1	
42	30H1-010F1	Thread tension spring	1	
43	22T1-012F10	Stop disc	1	
44	72T1-007F1	Thumb nut	1	
45	30H1-013	Thread guide	1	



## 2、 NEEDLE BAR AND THREAD TAKE-UP MECHANISM

No.	Ref. No.	Description	Pcs.	Remarks
1	82T6-002B	Needle bar	1	
2	30H2-001	Thread guide	1	
3	22T2-017	Needle clamp screw	1	
4	22T2-016	Needle	1	DB×1-2 #14
5	82T2-003C1a6	Set screw	1	SM11/64" (4.37)×40/7
6	22T2-007	Set screw	1	
7	22T2-006	Set screw	1	
8	22T2-005B	Needle bar crank complete	1	
9	72T2-004B2	Set screw	2	
10	22T2-020	Slide block	1	
11	22T3-001A2	Rubber plug	2	Φ7.4×10
12	22T3-003	Arm shaft bushing (left)	1	
13	30H2-002A	Arm shaft	1	
14	22T2-002	Set screw	4	
15	22T3-004	Arm shaft bushing (middle)	1	
16	22T6-005B	Collar for arm shaft	1	
17	22T3-002B2	Set screw	2	
18	22T3-010E2a1-2	Bevel gear for arm shaft	1	
19	22T3-010E2a2-2	Bevel gear for vertical shaft (upper)	1	
20	22T3-009D1b	C-type ring	1	
21	30H2-003B1a1	Feed and feed lifting eccentric	1	
22	30H2-003B1a4	Washer	1	
23	82T2-003C1a3	Set screw	3	SM9/64" (3.57)×40/7
24	72T3-002	Arm shaft bushing (right)	1	
25	72T3-003B	Oil seal	1	
26	30H2-003B1a2	Needle bearing	1	K25×29×10
27	82T2-003C1a5	Crank rod for feed rock shaft	1	
28	22T3-009D1c	Crank rod for feed lifting rock shaft	1	
29	22T3-011	Vertical shaft bushing (upper)	1	
30	22T3-010E1	Vertical shaft	1	
31	22T3-011	Vertical shaft bushing (lower)	1	
32	22T3-010E2b2-2	Bevel gear for vertical shaft (lower)	1	
33	22T3-010E2b1-2	Bevel gear for hook shaft	1	
34	22T2-005B3	Set screw	8	

### 3、 FEEDING NEEDLE MECHANISM

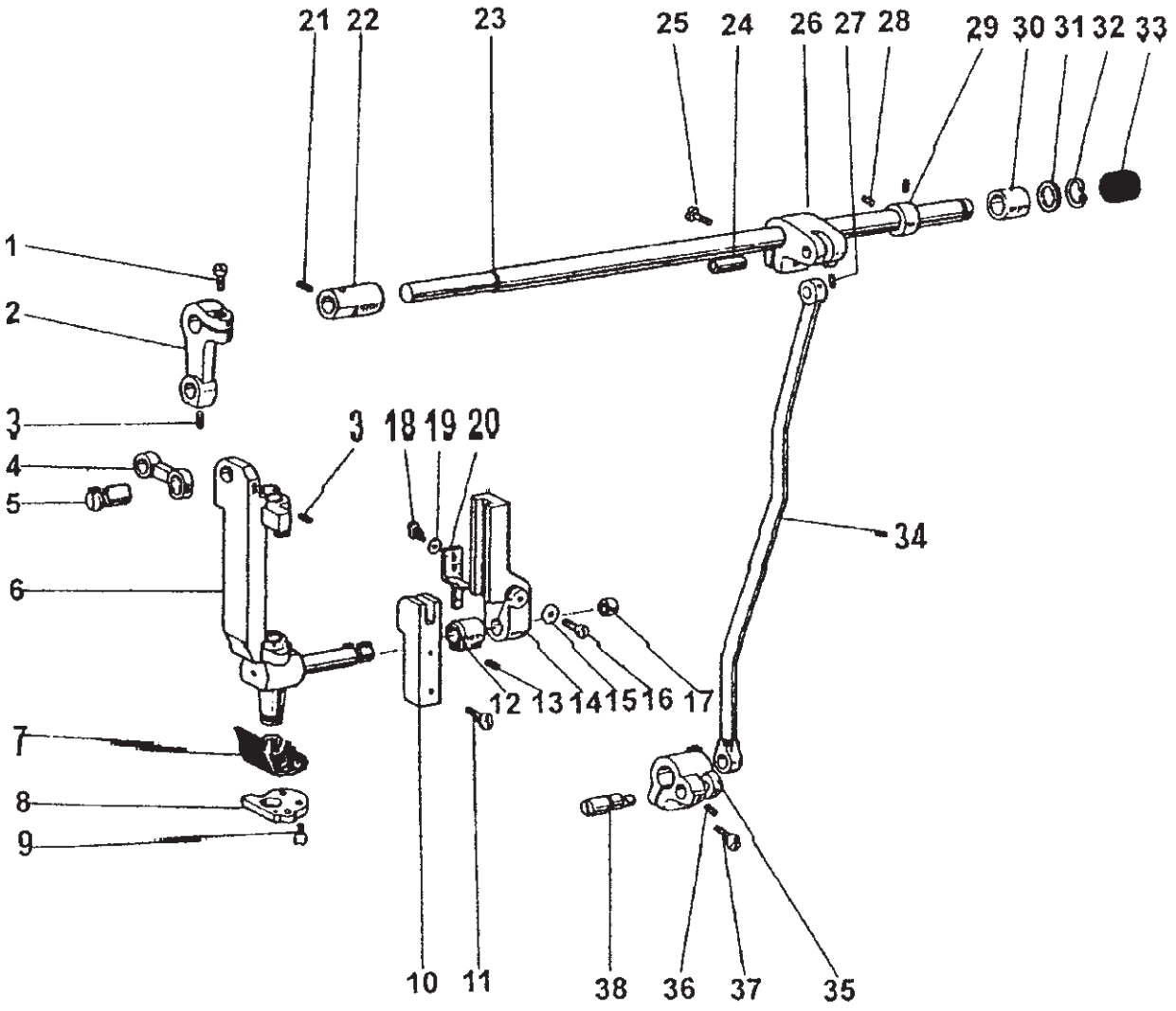

### 3. FEEDING NEEDLE MECHANISM

No.	Ref. No.	Description	Pcs.	Remarks
1	72T6-001A6	Set screw	1	SM3/16" (4.76) × 28/15
2	30H3-009E1	Needle bar vibrating lever	1	
3	22T1-011	Set screw	2	SM11/64" × 40/5
4	30H3-009E3	Needle bar vibrating lever link	1	
5	30H3-009E2	Needle bar vibrating lever link pin	2	
6	30H3-010F1a	Needle bar support complete	1	
7	30H3-012	Gasket for needle bar support	1	
8	30H3-015	Fitting plate for gasket	1	
9	30H3-016	Set screw	3	
10	30H3-017	Needle bar support guide bracket	1	
11	72T2-003	Set screw	2	
12	30H3-002	Needle bar support bushing	1	
13	30H3-003	Needle clamp screw	1	
14	30H3-010F1b1	Guide bracket for needle bar slide block	1	
15	GB95-85	Washer	1	Washer 5
16	72T6-001A6	Set screw	1	SM3/16" (4.76) × 28/15
17	30H3-011	Needle bearing	1	TLAM 810
18	22T6-001A4	Set screw	1	
19	GB848-85	Washer	1	Washer 3
20	30H3-013	Felt	1	
21	22T1-011	Set screw	2	SM11/64" (4.37) × 40/5.5
22	30H3-007C2	Rock shaft bushing (left)	1	
23	30H3-007C1	Rock shaft	1	
24	30H3-006B2	Rock shaft driving crank pin	1	
25	22T6-001A1b	Set screw	1	
26	30H3-006B1	Rock shaft driving crank	1	
27	22T1-011	Set screw	1	SM11/64" (4.37) × 40/5.
28	22T3-002B2	Set screw	2	SM1/4" (6.35) × 40/4
29	30H3-008D1	Collar for rock shaft	1	
30	30H3-007C3	Rock shaft bushing (right)	1	
31	30H3-007C4	Washer	1	
32	GB8894.2-86	C-type ring	1	Ring 12
33	30H1-011	Rubber plug	1	Φ 21.5
34	30H3-005	Crank rod for feed rock shaft	1	
35	30H3-001A1	Feed rock shaft driving crank	1	
36	72T6-001A6	Set screw	1	SM3/16" (4.76) × 28/15
37	30H3-010F1a7	Set screw	1	SM1/8" (3.175) × 44
38	30H3-004	Eccentric shaft	1	

# 4. ROTATING HOOK SHAFT MECHANISM

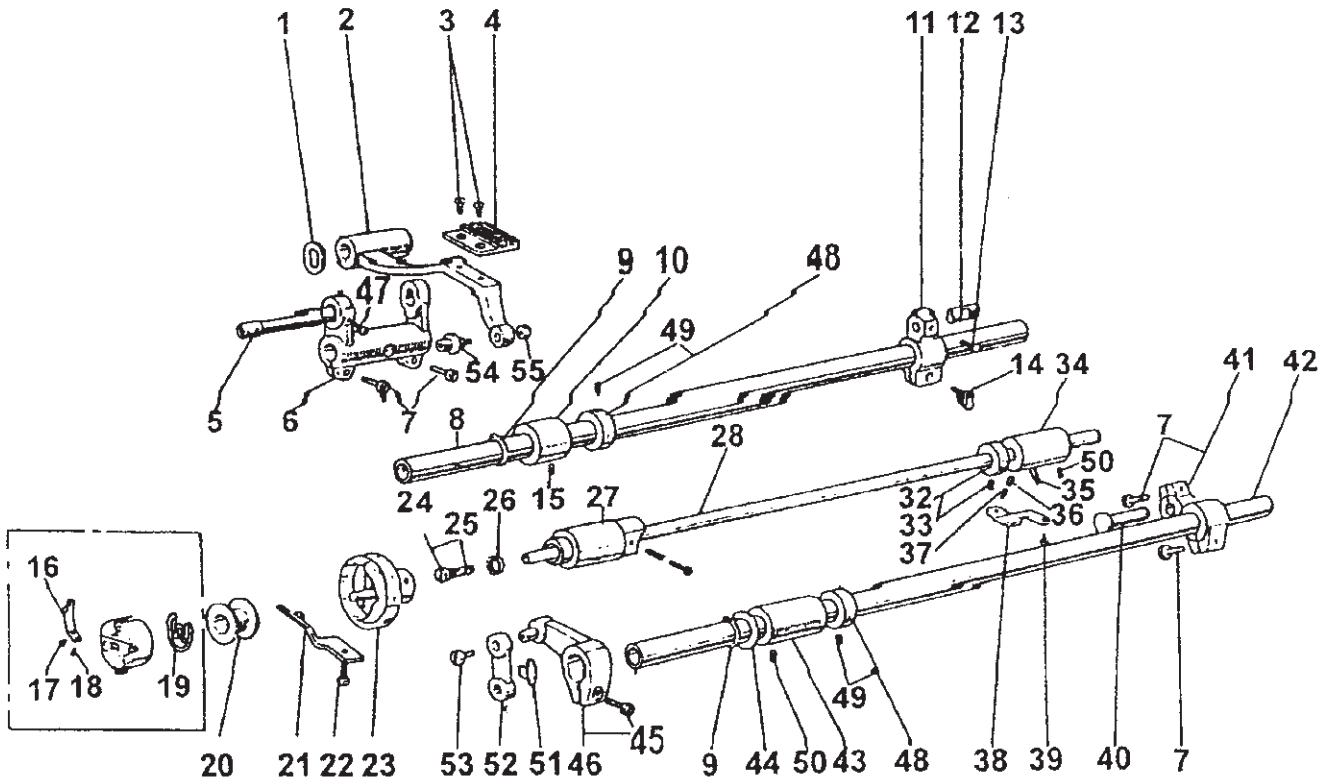

#### 4. ROTATING HOOK SHAFT MECHANISM

No.	Ref. No.	Description	Pcs.	Remarks
1	22T6-001A6	Washer	1	
2	30H4-003C1a	Feed bar	1	
3	22T6-001A4	Set screw	2	
4	30H4-004	Feed dog	1	
5	82T9-002A4	Shaft for feed bar crank (eccentric)	1	
6	22T6-001A1a	Feed rock shaft crank	1	
7	22T6-001A1b	Set screw	4	
8	72T6-005	Feed rock shaft	1	
9	GB894-76	C-type ring	2	Ring 15
10	22T6-004	Feed rock shaft bushing	1	
11	82T2-003C1a7	Feed rock shaft crank (right)	1	
12	82T2-003C1a10-2	Feed rock shaft crank pin	1	
13	82T2-003C1a8	Set screw	1	SM11/64" (4.37)×40/7
14	82T2-003C1a6	Set screw	1	SM11/64" (4.37)×40/12
15	72T4-002B2	Set screw	1	
20	22T4-017	Bobbin	1	
21	72T4-005	Rotating hook positioner	1	
22	22T4-015	Set screw	1	
23	30H4-001A	Rotating hook complete	1	
24	22T4-001A1a	Filter complete	1	
25	22T4-001A1a2	Filter	1	
26	22T4-003G	Oil seal	1	
27	22T4-004	Hook shaft bushing (left)	1	
28	72T4-001A1	Rotating hook shaft	1	
32	72T4-002B	Collar for rotating hook shaft	1	
33	72T4-002B2	Set screw	2	
34	72T4-008C1	Rotating hook shaft bushing (right)	1	
35	22T4-007C2	Oil pipe for rotating hook shaft	1	
36	72T4-010	Plunger	1	
37	72T4-011	Plunger spring	1	
38	72T4-004	Guide plate	1	
39	22T5-001A4	Set screw	1	
40	22T6-007	Hinge pin	1	
41	72T6-003C	Feed lifting rock shaft crank (right)	1	
42	72T6-002B3	Feed lifting rock shaft	1	
43	22T6-012	Feed lifting rock shaft bushing	1	
44	22T6-013	Washer	1	
45	22T6-008D3	Set screw	1	
46	30H4-006D	Feed lifting rock shaft crank (left)	1	
47	72T2-003	Set screw	1	
48	22T6-005B	Collar for Feed lifting rock shaft	2	
49	22T3-002B2	Set screw	4	
50	22T2-002	Set screw	2	
51	22T6-009F2	Holder	1	
52	22T6-009F1	Feed bar link	1	
53	22T6-010	Set screw	2	
54	22T6-001A9	Hinge pin	1	
55	22T6-001A8	Hinge pin nut	1	

# 5. STITCH LENGTH REGULATOR MECHANISM

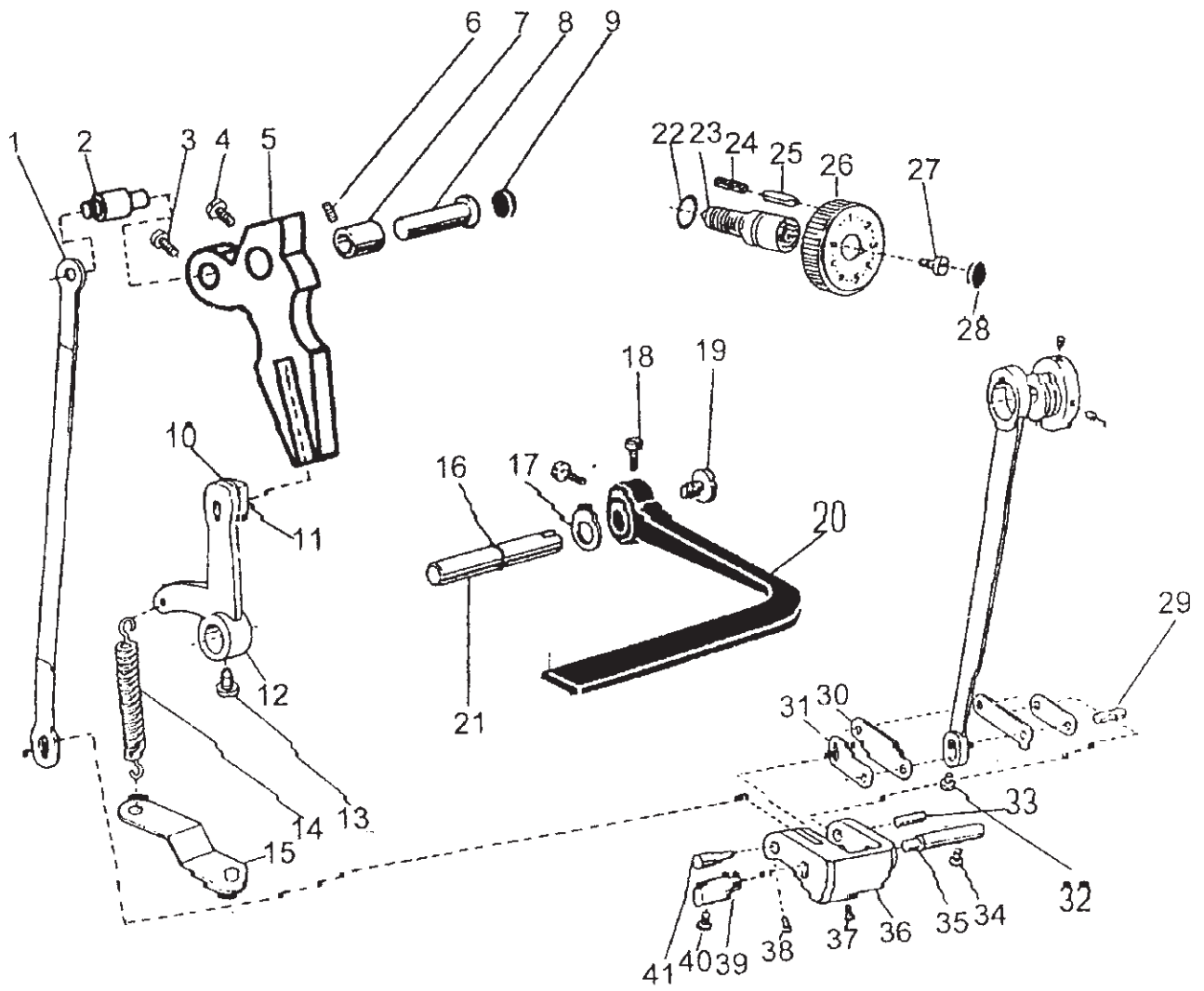

## 5. STITCH LENGTH REGULATOR MECHANISM

No.	Ref. No.	Description	Pcs.	Remarks
1	82T2-003C1a4	Feed connecting link	1	
2	12H4-001A2	Stitch length adjusting shaft	1	
3	22T2-019	Set screw	1	SM11/64" (4.37)×40/8
4	22T5-001A4	Set screw	1	SM15/64"(5.95)×28/10
5	12H4-001A1	Feed regulator	1	
6	22T2-002	Set screw	1	SM15/64"(5.95)×28/10
7	82T1-001A5	Feed regulator bushing	1	
8	22T5-004	Hinge pin for feed regulator	1	
9	82T1-012	Rubber plug	1	Φ20×6
10	22T5-012E1a1	Slide block pin	1	
11	22T5-012E1a2	Slide block	1	
12	22T5-012E1	Reverse feed lever feed crank	1	
13	22T5-013	Set screw	1	SM15/64" (5.95)×28/14.
14	22T5-012E2	Spring for reverse feed crank	1	
15	22T5-014	Bracker for spring	1	
16	22T5-010D2b	O-ring	1	9×1.9
17	22T5-011	Washer	1	
18	22T5-010D3	Set screw	1	SM3/16"(4.76)×28/6.5
19	22T5-001A4	Set screw	2	SM15/64"(5.95)×28/10
20	72T5-006C1	Reverse feed lever	1	
21	22T5-010D2a	Reverse feed lever pin	1	
22	22T5-006C4	O-ring	1	14×2.4
23	22T5-006C1	Feed regulator screw bar	1	
24	22T5-009	Spring for stopper pin	1	
25	22T5-008	Stopper pin	1	
26	82T5-004B1	Dial	1	
27	22T5-006C3	Set screw	1	SM3/16"(4.76)×28/8
28	72T5-005	Rubber plug	1	
29	82T2-003C1a10-2	Link stud	1	
30	82T2-003C1a9-2	Link ( long )	2	
31	82T2-003C1a9-1	Link ( Short )	2	
32	82T2-003C1a8	Set screw	1	
33	82T2-003C1a13	Link stud	1	
34	22T6-008D3	Set screw	1	
35	82T2-004	Feed regulator shaft ( right )	1	
36	82T2-003C1a15	Stitch length adjusting crank	1	
37	82T2-003C1a12	Set screw	1	SM9/64"(3.57)×40/8.5
38	82T2-003C1a11	Set screw	1	
39	82T2-005	Feed regulator shaft ( left )	1	
40	22T6-008D3	Set screw	1	
41	82T2-003C1a14	Link stud	1	

## 6. PRESSER FOOT MECHANISM

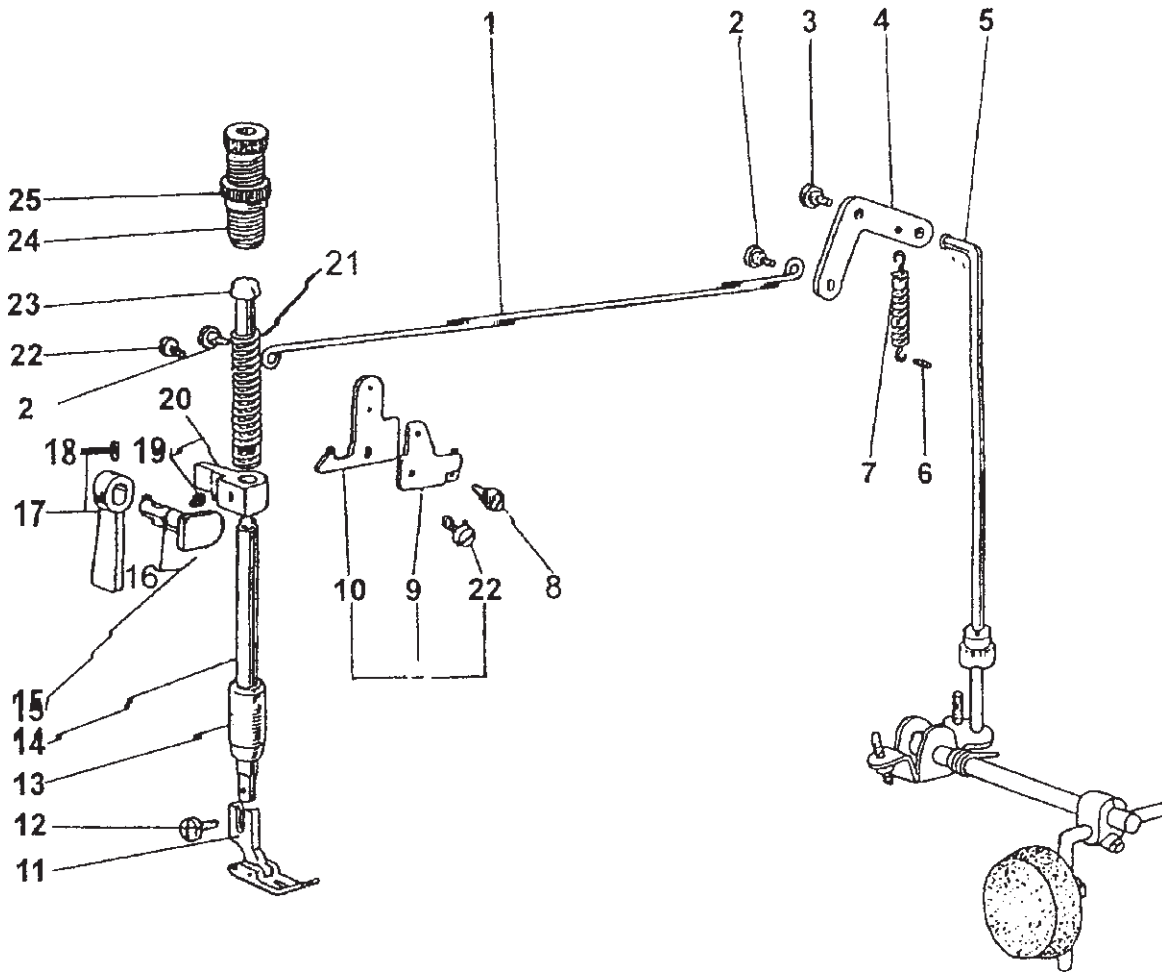

## 6、PRESSER FOOT MECHANISM

No.	Ref. No.	Description	Pcs.	Remarks
1	22T7-004B3	Knee lifter rod	1	
2	22T7-004B2	Set screw	2	
3	22T7-005	Set screw	1	
4	22T7-007C1	Knee lifter lever (right)	1	
5	72T7-003C1	Knee lifter connecting rod	1	
6	22T7-008	Pin for spring	1	
7	22T7-007C2	Spring for knee lifter lever	1	
8	22T7-005	Set screw	1	
9	72T7-002B1-1	Tension releasing cam	1	
10	82T8-003C1a1	Knee lifter lever (left)	1	
11	30H6-002B	Presser foot complete	1	
12	22T7-015	Set screw	1	SM9/64" (3.57) × 40/11
13	82T1-001A1	Presser bar bushing	1	
14	72T7-011	Presser bar	1	
15	82T8-002B1	Presser bar lifting cam	1	
16	72T7-008	Oil seal for presser bar lifting cam	1	
17	82T8-001A2	Presser bar lifter	1	
18	22T1-011	Set screw	1	
19	72T3-005D1a3	Set screw	1	
20	30H6-001A1	Presser bar lifting bracket	1	
21	73T7-001	Presser bar spring	1	
22	22T7-004B2	Set screw	1	
23	22T7-012	Presser bar guide	1	
24	72T7-006D1	Pressure regulating thumb screw	1	
25	22T7-014E2	Lock nut	1	

## 7. OIL LUBRICATION MECHANISM

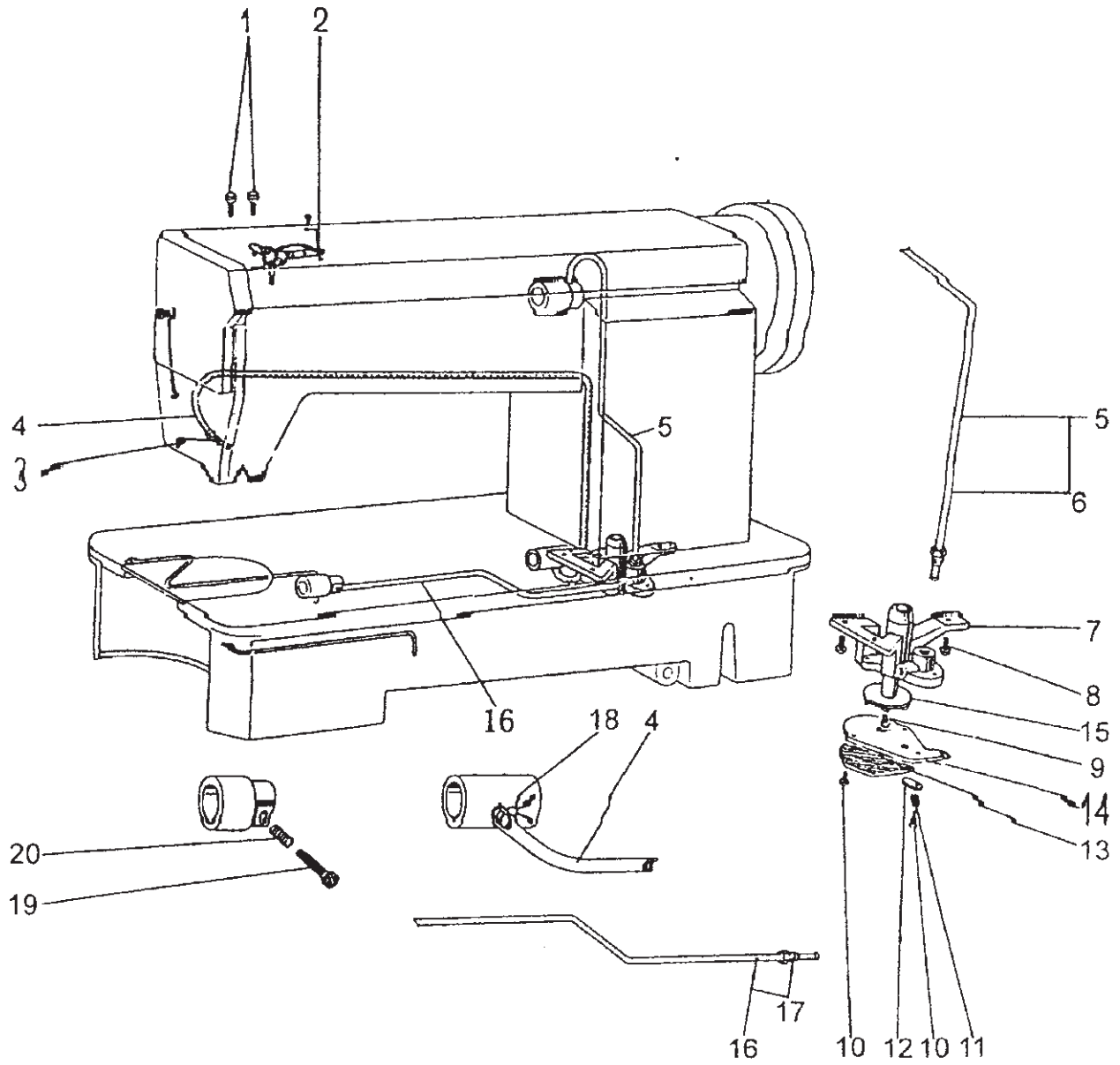

## 7、 OIL LUBRICATION MECHANISM

No.	Ref. No.	Description	Pcs.	Remarks
1	22T7-015	Screw	2	SM9/64" (3.57)×40/11
2	30H11-001A	Oil wick fitting plate complete	1	
3	30H11-002	Oil filter holder	1	
4	30H11-003A	Oil return tube complete	1	
5	22T8-013D	Arm shaft oil tube complete	1	
6	22T8-013D2	Arm shaft oil tube connector	1	
7	22T8-001	Oil pump	1	
8	22T8-009	Set screw	3	
9	22T8-003	Set screw	1	
10	72T8-005	Set screw	3	
11	22T8-005	Spring washer	1	
12	22T8-007	Oil adjusting plate	1	
13	22T8-008A	Oil pump screen complete	1	
14	82T11-003	Oil pump fitting plate	1	
15	22T8-002	Oil pump impeller	1	
16	22T11-004A	Oil pipe for hook shaft complete	1	
17	22T8-010B1	Oil pipe for hook shaft connector	1	
18	72T8-003	Oil return tube holder	1	
19	72T4-003	Oil adjusting screw	1	
20	22T4-006	Oil adjusting spring	1	

# 8, ACCESSORIES

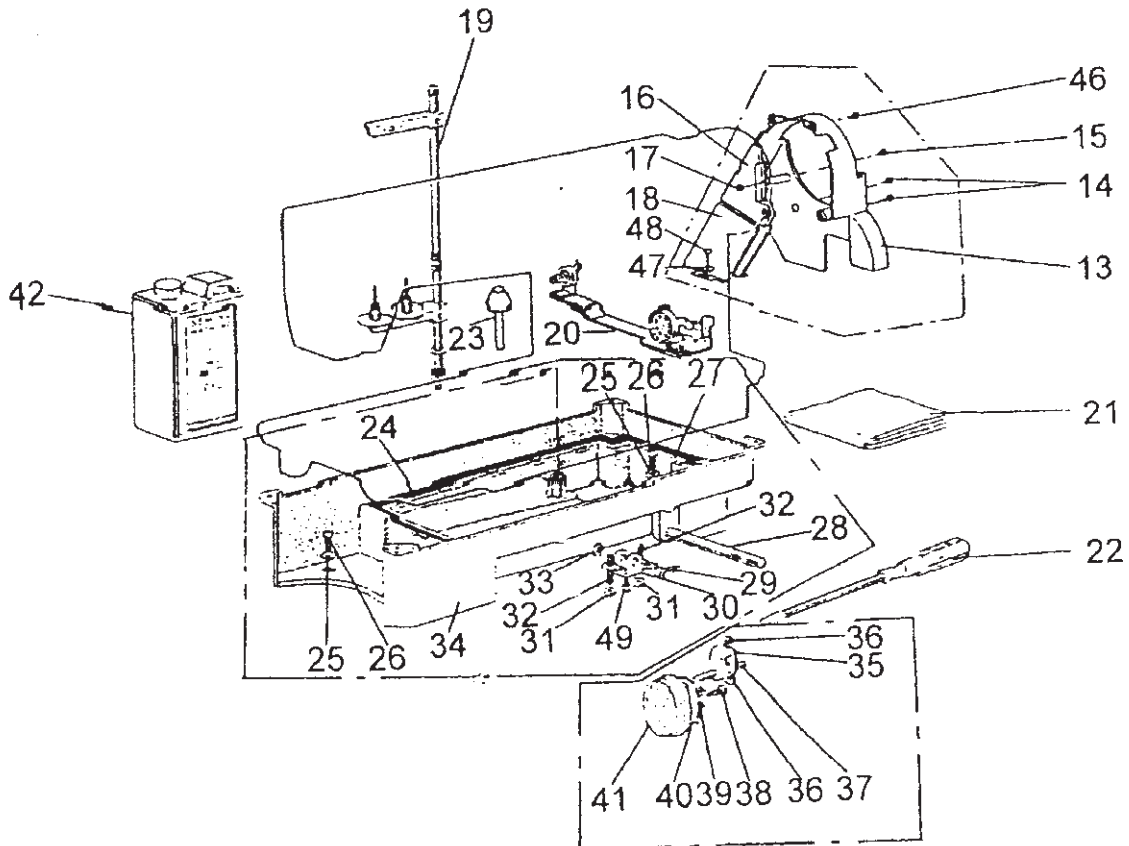
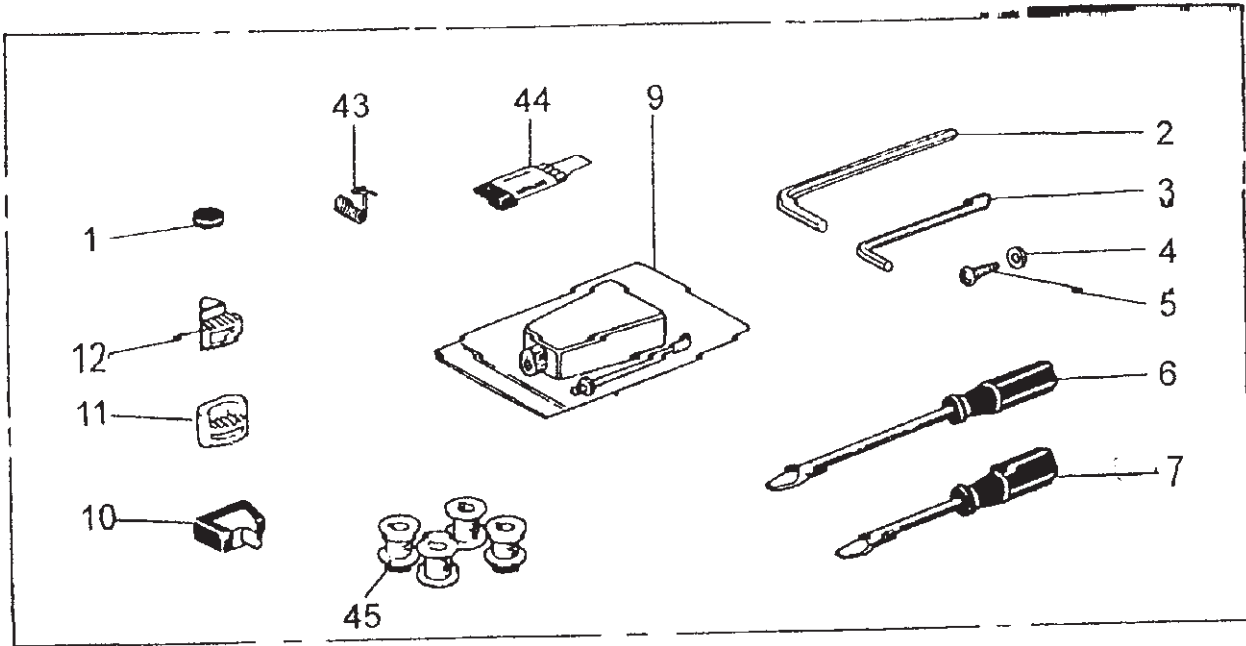

## 8. ACCESSORIES

No.	Ref. No.	Description	Pcs.	Remarks
1	22T9-012	Magnet block	1	
2		Hexagon socket screw-key 3	1	
3	82T18-001A3	Hexagon socket screw key 2	1	
4	72T9-023	Washer	2	Washer 5
5	GB99-76	Wood screw	2	4.5×20
6	72T9-020	Screw driver (Size M)	1	
7	72T9-021	screw driver (Size S)	1	
9	22T9-011	Oil with oiler	1	
10	72T9-004C	Hinge with rubber cushion	1	
11	72T9-005	Head cushion (large)	2	
12	72T9-006	Head cushion (small)	2	
13	72T9-002B6	Belt cover	1	
14	72T9-028	Set screw	2	
15	72T9-025	Screw	1	M4×12.5
16	72T9-002B2	Belt cover complete	1	
17	GB52-76	Nut	1	M4
18	72T9-002B5	Belt cover	1	
19	82T18-004D	Thread stand complete	1	
20	82T18-003C	Bobbin winder complete	1	
21	72T9-019	Head cover	1	
22	72T9-013	Screw driver (Size L)	1	
23	22T9-003B1	Knee lifter lifting rod	1	
24	22T9-001A4	Gasket for oil reservoir (small)	1	
25	22T9-001A3	Seal washer	2	
26	22T9-001A2	Oil drain screw	2	SM5/16"(7.94)×28/10
27	22T9-001A5	Gasket for oil reservoir (large)	1	
28	72T9-016	Knee lifter shaft	1	
29	22T9-001A7	Knee lifter spring	1	
30	22T9-001A8	Knee lifter	1	
31	22T9-001A10	Nut	2	
32	22T9-001A9	Set screw	2	SM15/64"(5.95)×28/28
33	GB896-76	E-type ring	1	Ring 9
34	72T9-001A1	Oil reservoir	1	
35	22T9-003B3	Knee lifter coupling joint	1	
36	72T9-018	Bolt	2	
37	22T9-003B2	Knee lifter bell crank	1	
38	22T9-003B7	Screw	1	
39	22T9-003B6	Gasket for Knee lifter plate	1	
40	22T9-003B5	Knee lifter plate	1	
41	22T9-003B8	Pad for knee plate	1	
42	72T9-017	Oil tank	1	
43	22T1-012F6	Thread take-up spring	1	
44	72T9-031	Needle	1	DB*1 14# 4
45	22T4-017	Bobbin	3	
46	72T1-017	Screw	2	SM11/64"(4.37)×40/8
47	72T9-023	Washer	2	
48	GB99-76	Wood screw	2	4.5×20