

MAIN SPECIFICATIONS

Item	GC128-M	GC128-H	GC128-B
Material weight	Typical	Heavy	Heavy
Max sewing speed (spm)	5000	3500	3000
Needle	DB×1 No.14	DB×1 No.22	DB×1 No.22
Needle bar stroke (mm)	31.8	35	35
Lubrication	Automatic lubrication, has reverse feeding mechanism		
Stitch length	0-5	0-8	0-8
Presser	By hand (mm)	5	6
	By knee (mm)	13	13
Bobbin			Double capacity of thread

2. INSTALL THE MOTOR (Fig.1)

Align Motor Pulley Groove (B) and Balance Wheel Groove (A) by moving the motor leftward or rightward.

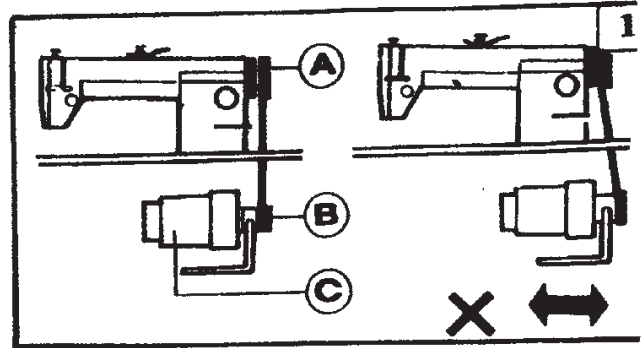

3. CONNECT THE CLUTCHLEVER WITH THE PEDAL (Fig. 2)

1) The optimum tilt angle of Pedal (A) is approximately 15 deg.

2) Adjust Clutch Cover (D) so that Clutch-Lever (C) and Draw Bar (B) run in line.

3) The balance wheel should rotate counter-clockwise when viewed from the outside of Balance Wheel (G). The direction of the motor pulley rotation can be reversed by reversing (turning over 180 deg.) the power lug of the motor.

4) Adjust the tension of V-belt (F) by turning Motor Vertical Position Screw (E). The proper tension of the V-belt is a slack of 10-20mm when the belt is depressed at the center of the belt by finger.

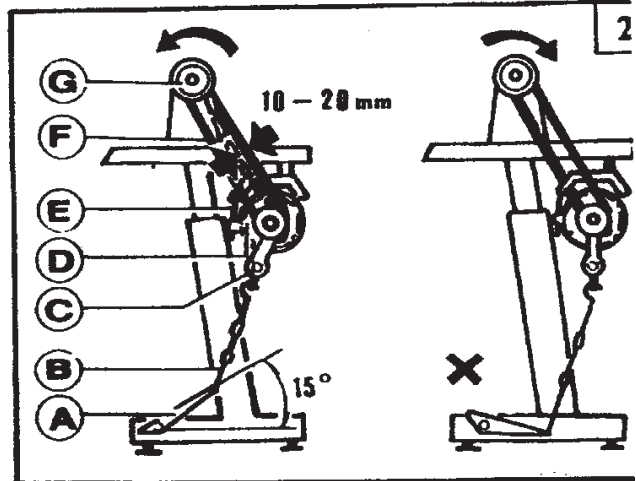

4. PREPARATION AND LUBRICATION (Fig.3)

1) Cleaning the machine

Before leaving the factory, the machine parts are coated with rust-preventive grease, which may be hardened and contaminated by dust during storage and shipment. This grease must be removed with gasoline.

2) Examination

Though every machine is confirmed by strict inspection and test before leaving the factory, the machine parts may be loose or deformed after long distance transportation with jolt. A thorough examination must be performed after cleaning the machine. Turn the balance wheel to see if there is running obstruction, parts collision, uneven resistance or abnormal noise. If these exist, adjustment must be made accordingly before run-in operation.

3) Oiling

(1) Required amount of oil

Line (A) on the oil reservoir: Max. oil level.

Line (B) on the oil reservoir: Min. Oil level.

If oil level goes down under Line (B), oil can be distributed to each part of the machine, causing the parts a seizure.

(2) Replenishing

Always use only No. 18 special machine oil high speed sewing. Be sure to replenish oil to Line before starting operation.

(3) Replacing oil

To replace oil, remove Screw (C) to drain. After completely draining off oil, clean the oil reservoir and securely tighten Screw (C), then fill the reservoir with fresh oil.

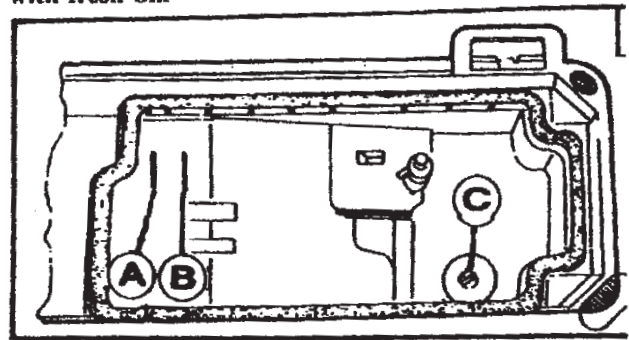

5. REPLACE NEEDLES (Fig.4)

Turn the balance wheel to lift needle bar to the upper end of its stroke. Loosen Needle Clamp Screw A. While keeping the long groove of the needle leftward fully insert the needle shank up to the bottom of the needle socket. Then tighten Needle Clamp Screw A.

Note: Fig. (b): insufficient insertion.

Fig. (c): wrong direction of long groove.

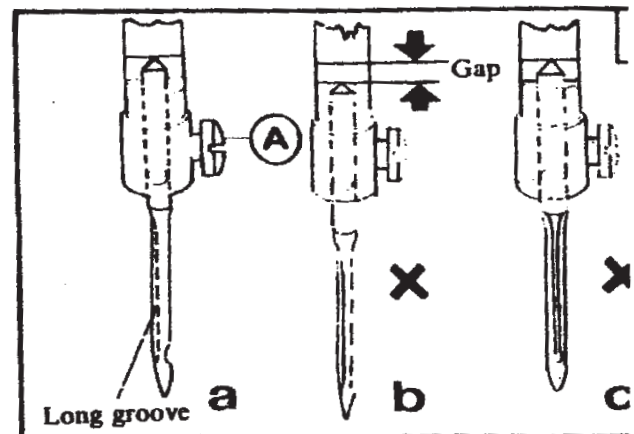

6. NEEDLE, THREAD AND MATERIAL TO BE SEWN

Needle Size	Thread Number	Material
No.9	No.100-No.80	Georgette, Hard Crepe
No.11	No.80-No.60	Silk, Muslin, Poplin
No.14	No.60-No.50	Cotton, Woolen
No.16	No.50-No.30	Woolen, Tarpaulin, Thin Leather

RUN-IN OPERATION (Fig. 5)

Run-in operation is required for a new sewing machine, or a sewing machine left out of operation for considerable length of time.

- 1) Remove Red Rubber Plugs (A) on the top of the arm and replenish sufficient amount of oil.
- 2) Lift Presser Foot (B)
- 3) Run the machine at a low speed (10% - 50% of Max. speed) to check oil distributing condition through Oil Check Window (C).
- 4) Perform run-in operation at 40% - 50% of Max. speed 30 minutes. After a lapse of one month of service during which the working speed is increased gradually and the machine is sufficiently well, the Max. speed can be adopted according to the nature of the work.

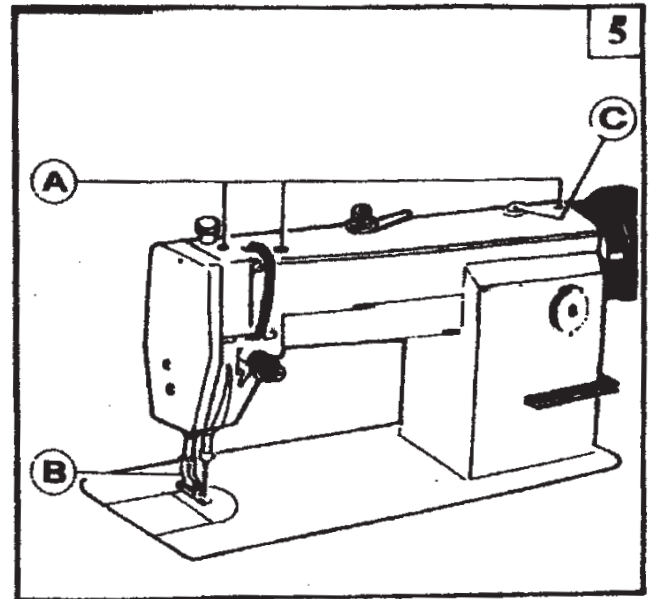

8. THREADING (Fig. 6)

To thread the needle thread, raise needle bar to the upper end of its stroke, lead the thread from spool and perform threading as shown in Fig. 6. To draw up bobbin thread; hold the end of the needle thread and turn the balance wheel to lower the needle bar and then to lift it to its highest position. Pull the needle thread and the bobbin thread is drawn up. Put the ends of needle thread and bobbin thread forward under presser foot.

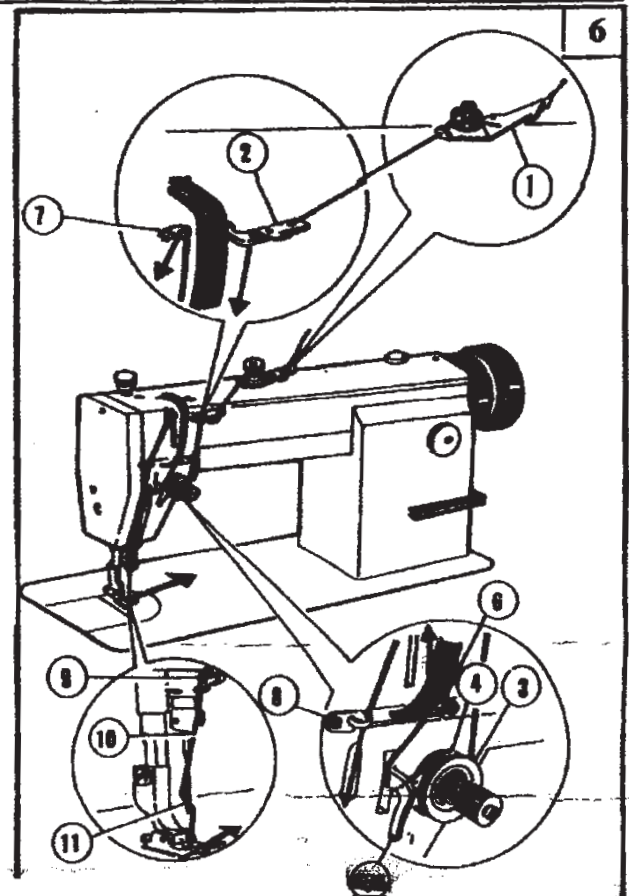

9. WINDING ADJUSTMENT (Fig. 7)

1) The wound bobbin thread should be neat and tight, if not, adjust the winding tension by turning Tension Stud Nut (A) of bobbin winder tension bracket.

Note: nylon or polyester thread should be wound with little tension, otherwise, Bobbin (D) might break or deform.

2) When the wound thread layer does not present a cylindrical shape as shown in Fig. 7 (a), loosen Set Screw (B) of bobbin winder tension bracket and slide Bracket (C) leftward or rightward. If thread is wound as shown in Fig. 7 (b), move the bracket rightward, but if thread is wound as shown in Fig. 7 (c), move the bracket leftward.

After adequately positioning the bracket, tighten Set Screw (B).

3) Do not overfill the bobbin. The optimum length of thread will fill about 80% of bobbin capacity. This can be adjusted by Adjusting Screw (E) of bobbin winder stop latch.

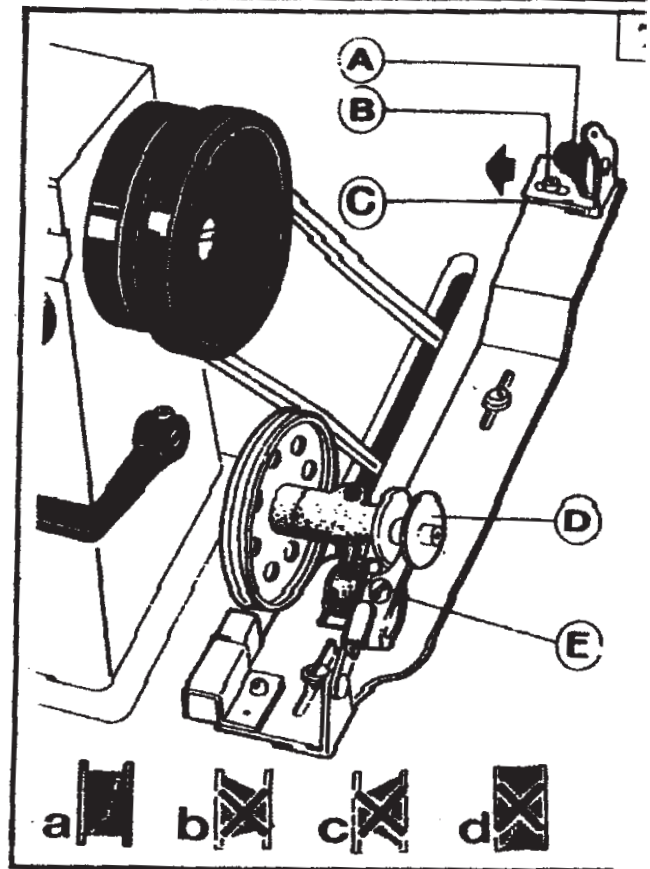

10. SET STITCH LENGTH AND REVERSE FEEDING (Fig. 8)

1) Stitch length can be set by turning Dial (A).

2) The figures on Face (B) of dial show stitch length in mm.

3) Reverse feeding starts when Reverse Feed Lever (C) is depressed, and the machine will feed forward again if Reverse Feed lever (C) is released.

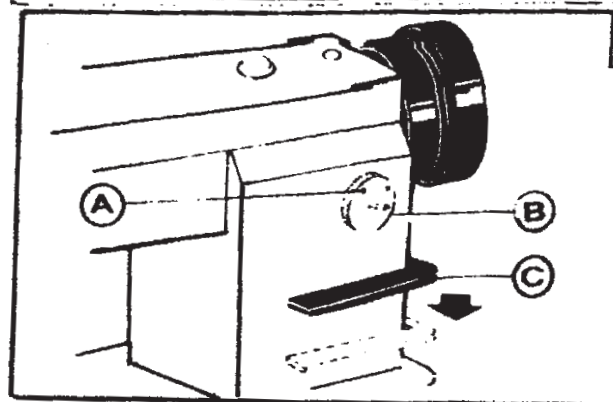

11. POSITION PRESSER BAR (Fig. 9)

- 1) Loosen Lock Nut (E) and Pressure Regulating Thumb Screw (A).
- 2) Remove rubber plug from Face Plate (B).
- 3) Loosen Screw (C) and adjust the position of Presser Bar till the presser foot is 5.0mm(GC128-M: 5.0mm, GC128-H and GC128-B: 6.0mm) above the throat plate with the presser foot lifted to its highest.
- 4) Tighten Screw (C) and put in the rubber plug.
- 5) Tighten Pressure Regulating Thumb Screw (A) and Lock Nut (E).

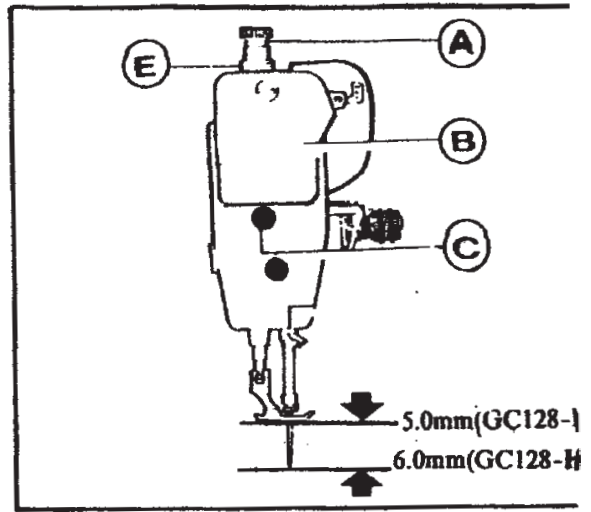

12. ADJUST THE PRESSURE OF PRESSER FOOT (Fig. 10)

Pressure of presser foot is to be adjusted in accordance with thickness of materials to be sewn.

First loosen Lock Nut (A). For heavy materials, turn the pressure regulating thumb screw as shown in Fig. 10 (a) to increase the pressure, while for light materials, turn the pressure regulating thumb screw as shown in Fig. 10 (b) to decrease the pressure. Then tighten Lock Nut (A).

The pressure of presser foot is recommended to be less as long as normal feeding is ensured.

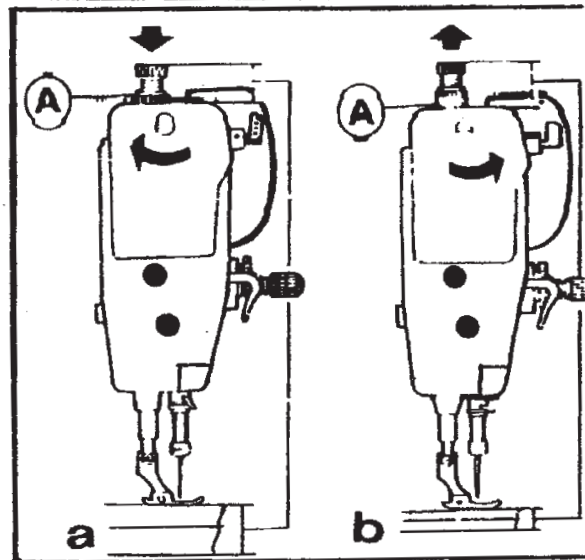

13. ADJUST THREAD TENSION (Fig. 11, 12)

In principle, thread tension is to be adjusted in accordance with materials, thread and other factors.

In practice, thread tension is adjusted according to the stitches obtained. The needle thread tension should be adjusted with reference to the bobbin thread tension. Turn Tension Spring Regulating Screw (A) of bobbin case clockwise for more tension, or turn the screw counter-clockwise for less tension.

It is common practice to test the bobbin thread tension as shown in Fig. 12. Hold the end of the thread from delivery eye. If the bobbin case is falling slowly, the proper tension is obtained. The needle thread tension can be adjusted by setting (1) the thread take-up spring tension, (2) the thread take-up spring stroke and (3) tension spring. All these adjustments will be described in the following.

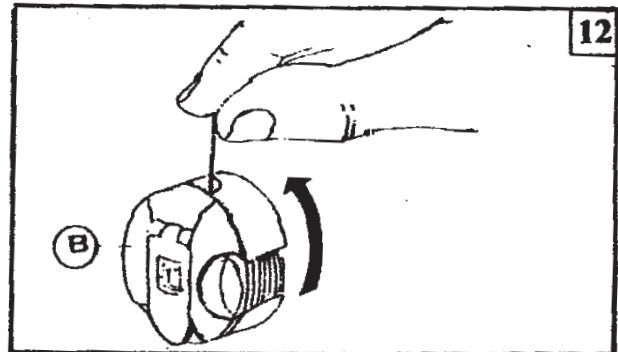
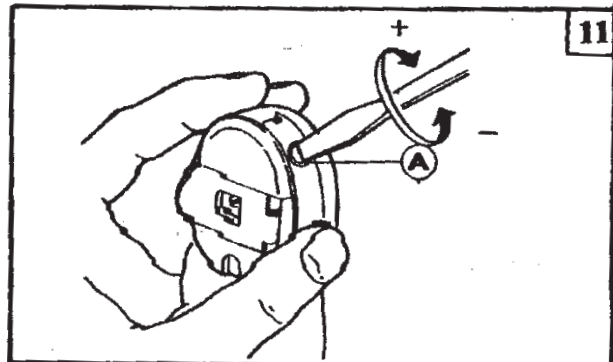

14. ADJUST THREAD TAKE-UP SPRING (Fig. 13, 14)

1) Adjusting the thread take-up spring tension

Loosen Set Screw (A), turn Tension Stud (B) clockwise to increase the spring tension, or turn the stud counter-clockwise to decrease the spring tension. After the adjustment, be sure to tighten Set Screw (A). The thread take-up spring tension should be about 30g. To attain this, first loosen Set Screw (A), turn Tension Stud (B) counter-clockwise to decrease the tension of Thread Take-up Spring (C) to zero, then turn Tension Stud (B) clockwise until Spring (C) comes to the notch of thread tension regulating bushing, and again turn Tension Stud (B) halfway back (counter-clockwise) after the adjustment, tighten Set Screw (A).

2) Adjusting the thread take-up spring stroke

Loosen Set Screw (B), turn Stud (C) clockwise to increase the stroke or turn Stud (C) counter-clockwise to decrease the stroke. After the adjustment, tighten Set Screw (B).

Before leaving the factory, the thread take-up spring has properly been adjusted. Readjustment is needed only in the case of special material or special thread.

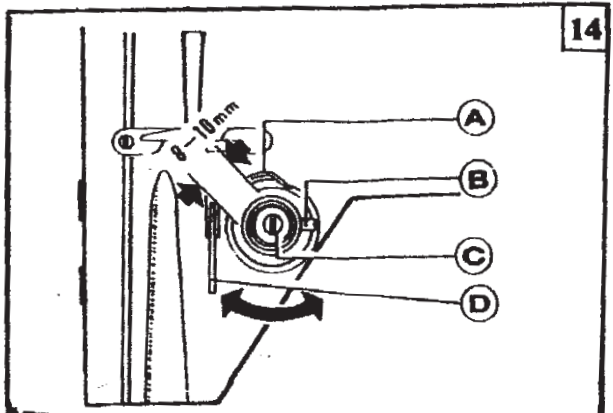
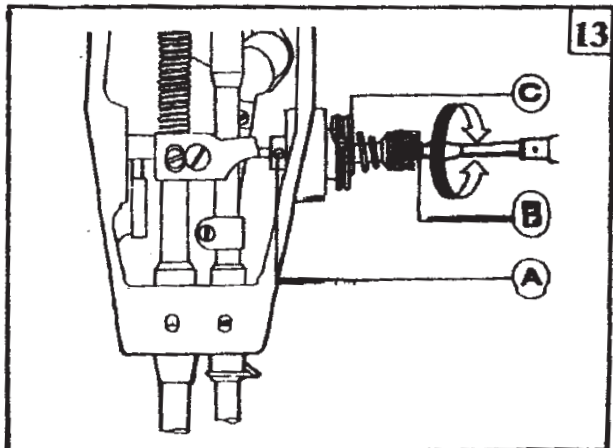

15. ADJUST THREAD GUIDE AND THREAD TENSION (Fig.15,1)

The position of the thread guide affects stitch tightness and therefore must be adjusted according to sewing materials and sewing conditions.

	1	2	3
Thread guide position	Leftward	Center	Rightward
Material weight	Heavy	Medium	Light

Fig. 15 shows different stitch forms. Normal stitch form should be as shown in Fig. 15 (a). When abnormal stitches cause puckering and thread breakage, the tension of needle thread and bobbin thread must be adjusted accordingly.

1) In case needle thread tension is too strong or bobbin thread tension is too weak, as shown in Fig. 15 (b), turn the thumb nut counterclockwise to decrease the needle thread tension, or tighten the tension spring regulating screw of bobbin case to increase the bobbin thread tension (See Fig. 16)

2) In case needle thread tension is too weak or bobbin thread tension is too strong, as shown in Fig. 15 (c), turn the thumb nut clockwise to increase the needle thread tension, or loosen the tension spring regulating screw or bobbin case to decrease the bobbin thread tension.

3) In case of the stitch forms as shown in Fig. 15 (d) and (e), adjustments can be made with reference to the above means.

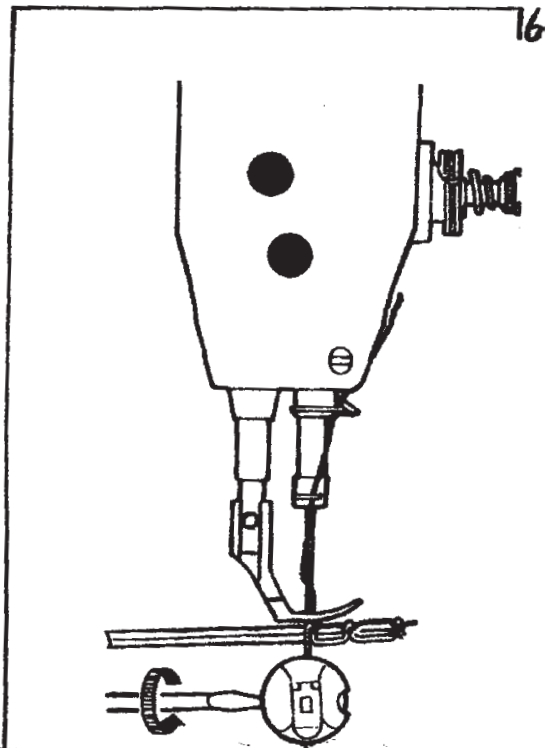
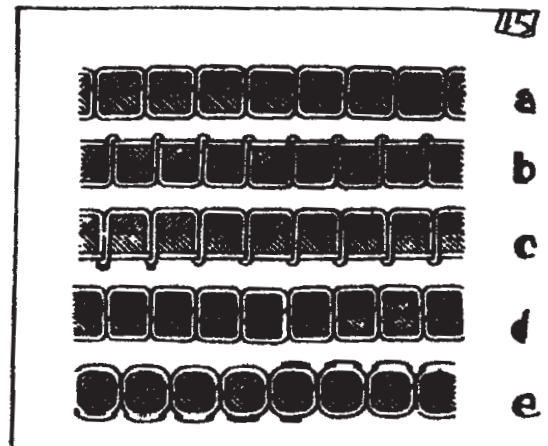

16. TIME NEEDLE TO ROTATING HOOK (Fig. 17,18,19,20)

A. Adjusting the needle position (See Fig.17)

- 1) Turn balance wheel by hand to bring Needle bar (C) to the lowest position of its stroke.
- 2) Remove rubber plug from Face Plate (A)
- 3) Loosen Set Screw (B) of needle bar adaptor.
- 4) Move Needle Bar (C) vertically to adjust needle timing.

5) After the adjustment, tighten Set Screw (B) and put in the rubber plug. The standard needle timing (See Fig. 18) is to align Timing Mark (B) on the needle bar and the bottom of Needle Bar Bushing (A) and meanwhile align the Inner Surface (E) of the hook and the center of Needle Eye (D) when the needle bar gets down to its lowest position.

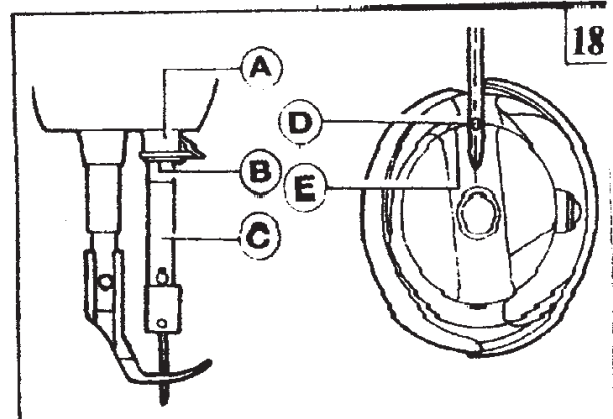
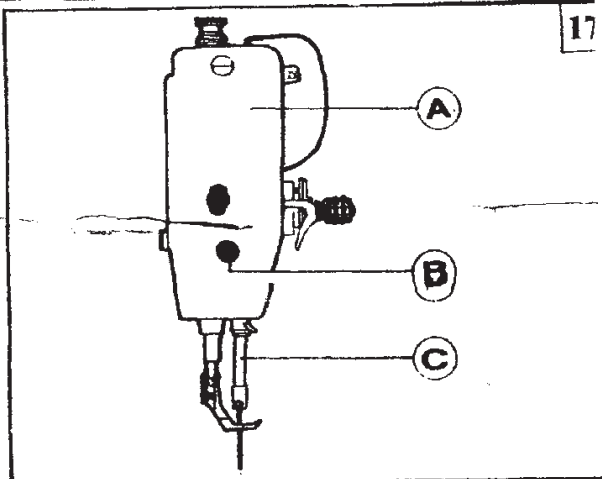

B. Adjusting the hook point timing

Timing of needle motion to rotating hook motion has a great effect on sewing performance. The standard hook point timing (See Fig.19) is to align Hook Point (D) and Needle Centerline (C) when Needle Bar (B) is lifted by 2.2mm (GC128-B:2.2mm, GC128-M and GC128-H: 2.4mm) of its stroke. (2.4 mm suitable for type B and type C). Besides, Hook Point (D) should be 1.0- 1.5mm above the upper end of needle eye (E).

When adjusting the hook point timing, also notice that the clearance between the bottom of needle notch and Hook Point (C) should be approx 0.05mm (See Fig.20)

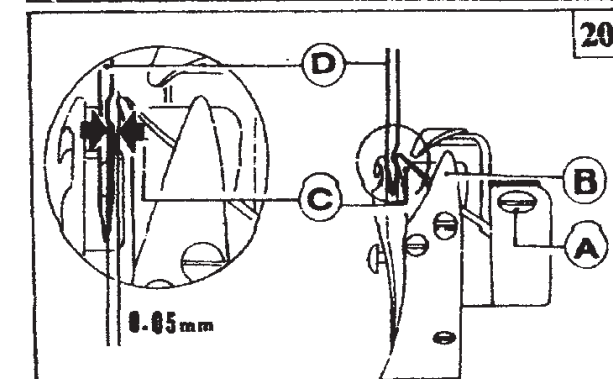
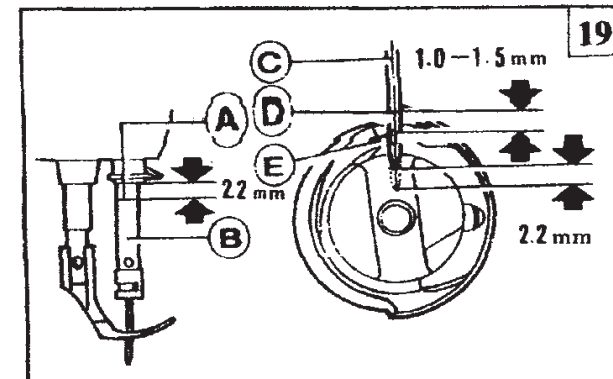

17. REPLACE ROTATING HOOK (Fig.21)

1) Lift needle bar to the highest position of its stroke. 2) Remove throat plate, take down needle and bobbin case.

3) Loosen Screw (C) of hook positioner and take down Hook Positioner (A).

4) Loosen two Screws (D) of rotating hook.

5) Turn balance wheel to raise feed bar to its highest position, then take down the rotating hook by turning it away from feed bar.

6) Installing the hook can be done in reverse sequence. Note that Needle (B) and the convex surface of Hook Positioner (A) should align with a clearance of 0.5–0.7mm between them.

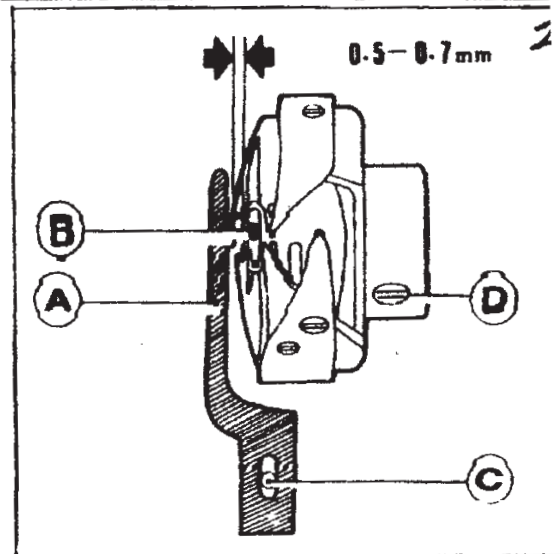

18. ADJUST THE HEIGHT OF FEED DOG (Fig. 22,23)

1) Turn balance wheel until feed dog is lifted to its highest position from throat plate surface.

2) Loosen Screw (A) of feed lifting rock shaft crank right (See Fig. 22, b)

3) Move Feed Bar (B) in the direction shown by the arrow in Fig. 22 (a) to adjust the height of the feed dog. The standard height of feed dog is that the top of feed dog is 1.0mm above Throat Plate Surface (B).

4) After the adjustment, be sure to tighten Screw (A).

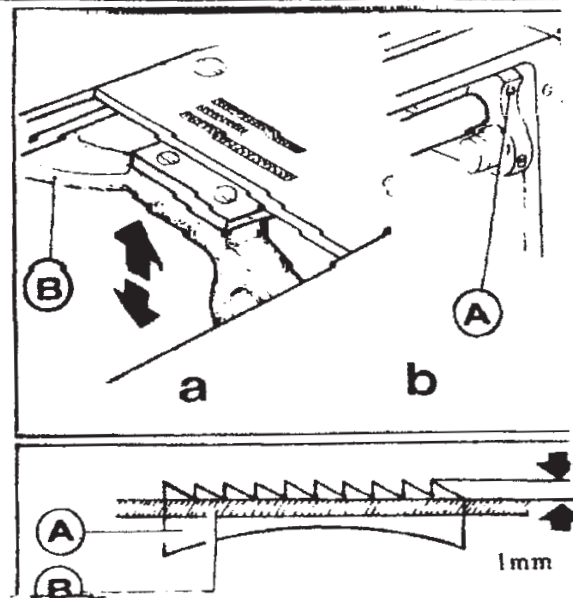

19. ADJUST THE POSITION OF FEED DOG (Fig.24, 25)

The standard position of feed dog is that the arance between the front end of the throat plate slot and the first tooth of the fully advanced feed dog is 0.8mm, as shown in Fig. 24.

1) Fully advance the feed dog toward the front end of the throat plate slot.

2) Loosen Feed Rock Shaft Crank Screw (A). See Fig. 25 (b).

3) Move Feed Bar (B) in the direction shown by the arrow in Fig. 25 (a) to adjust the feed dog position.

4) After the adjustment, be sure to tighten Screw (A).

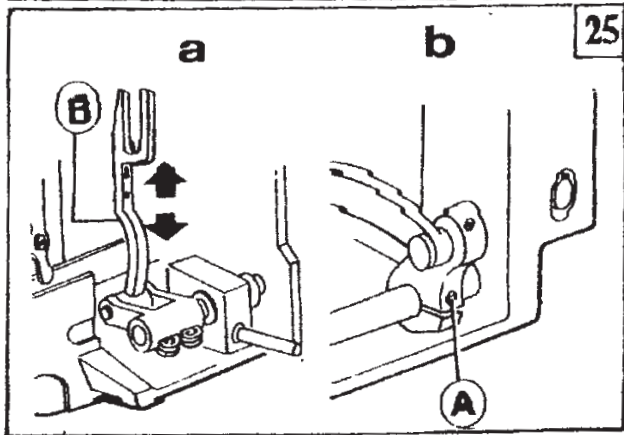
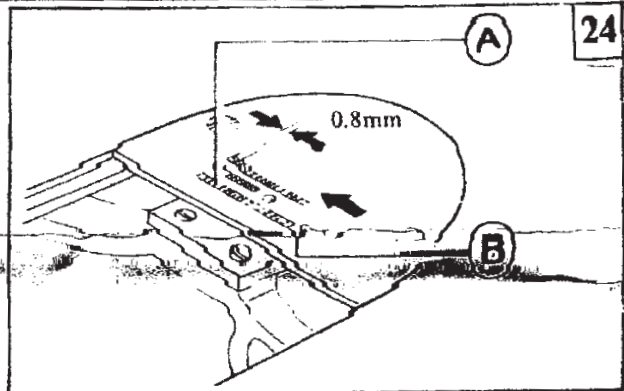

20. TIME FEED MOTION TO NEEDLE MOTION (Fig.26, 27, 28)

The standard timing of feed motion to needle motion is that the top of Feed Dog (C) is flush with Throat Plate Surface (B) when the point of Needle (A) reaches Throat Plate Surface (B). See Fig.26

If feed motion is not timed to needle motion, adjust as follows (See Figs. 27 and 28)

1) Remove Arm Side Cover (F).

2) Loosen Set Screws (A) and (D) of feed and feed lifting eccentric.

3) Hold Feed and Feed Lifting Eccentric (B) and urn Balance Wheel (E) slowly until the upper edge of Arm Shaft Oil Hole (C) aligns with the lower edge of Reference Hole (G) of feed and feed lifting eccentric.

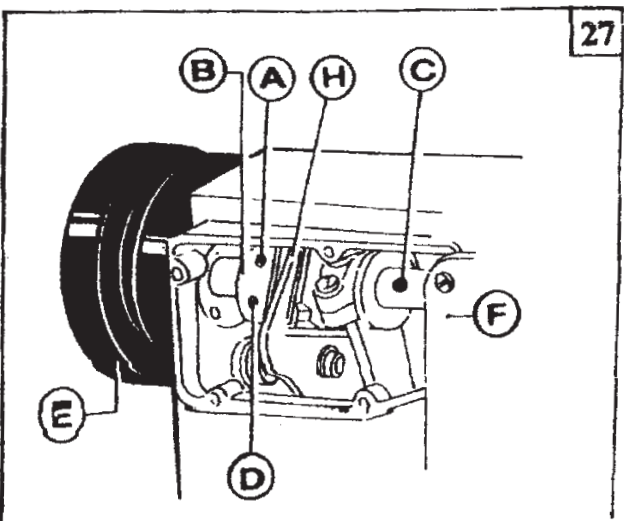
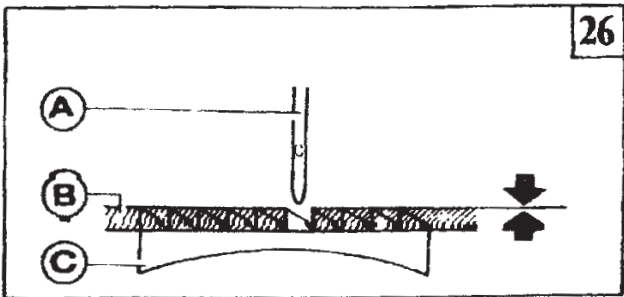

4) Leave a clearance of 0.3-0.5mm between Feed and Feed Lifting Eccentric (B) and Eccentric Sleeve (H), then tighten Set Screws (A) and (D).

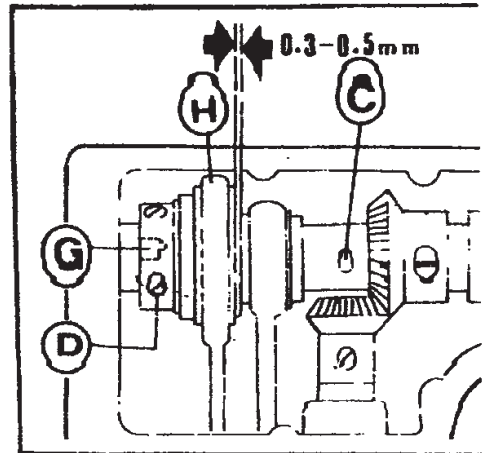

21. ADJUST OPENING TIME OF THE TENSION DISCS (Fig.

Within the presser foot lift range of 2-7mm opening time of the tension discs can be adjusted as follows:

1) Remove the rubber plug from the back of arm and loosen Screw (A) of knee lifter lever (left).

2) Move the tension releasing cam leftward for earlier opening or rightward for later opening. It will facilitate the adjustment to put under the presser foot a block as thick as the presser foot lift.

3) After the adjustment, fully tighten Screw (A).

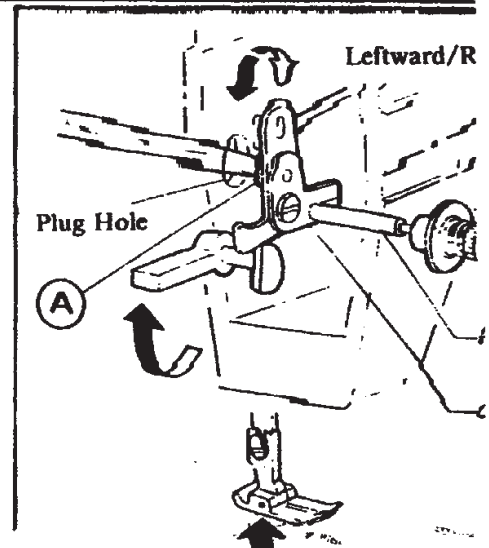

22. LUBRICATION ADJUSTMENT (Fig. 30)

Adjusting the lubrication of rotating hook

The lubrication of the rotating hook can be adjusted by Oil Adjusting Screw (A) as follows:

1) Turn Oil Adjusting Screw (A) clockwise to increase oil and turn Oil Adjusting Screw (A) counterclockwise to decrease oil.

2) Oil Adjusting Screw (A) adjusts oil amount within 5 turns. When Oil Adjusting Screw (A) is fully tightened, oil amount is maximum.

3) Readjustment depends on temperature, sewing speed and the like. In practice, oil amount can be judged as follows: remove the throat plate and place a piece of paper on instead, run the machine for about 20 seconds, then check the oil splashed on the paper.

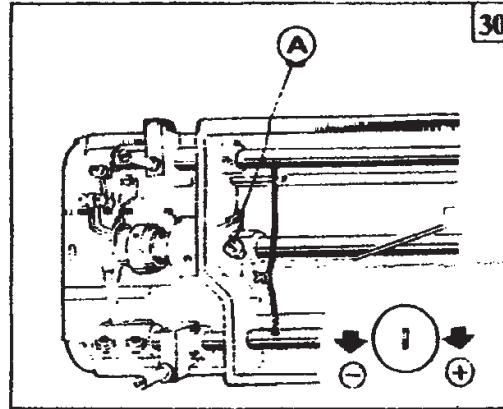

23. REGULAR CLEANING (Fig.31, 32, 33)

1) Cleaning feed dog (See Fig.31)

Remove the throat plate and clear off the dust and lint between feed dog tooth slots.

2) Cleaning rotating hook (See Fig.32)

Swing out the machine head and clean the hook. Wipe the bobbin case with soft cloth.

3) Cleaning oil pump screen (See Fig.33)

Swing out the machine head and clear off the dust and dirt on the oil pump screen.

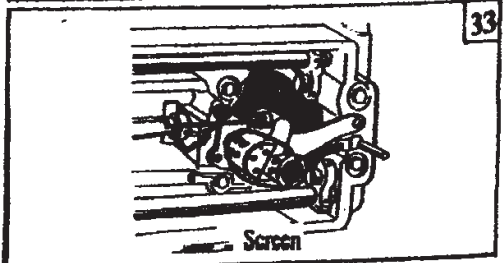
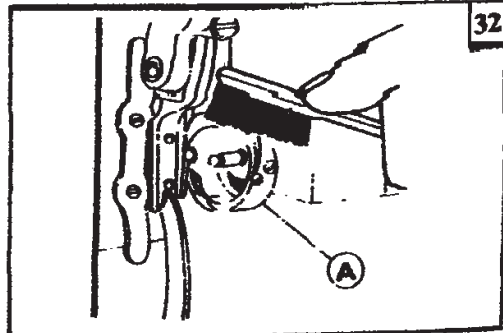
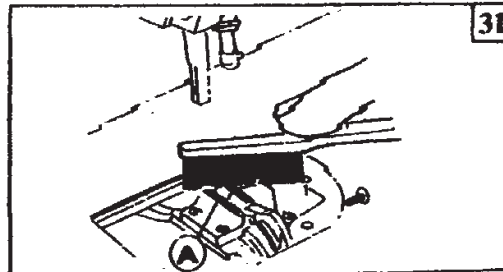

1

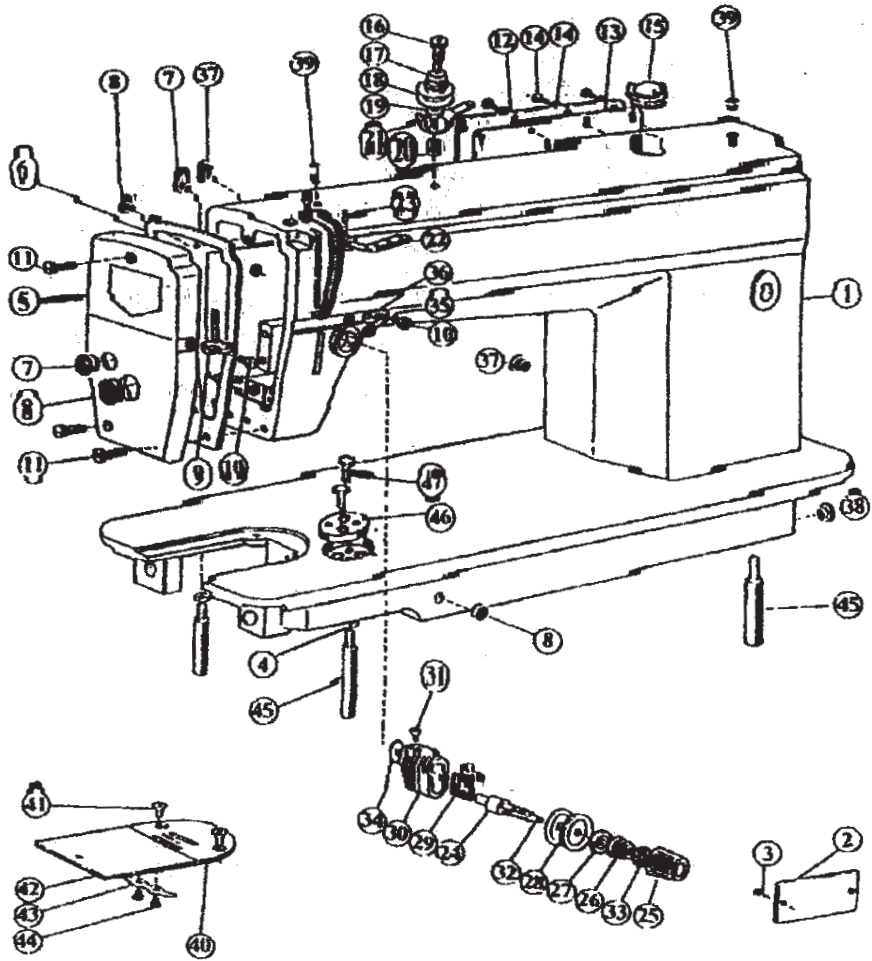

5550

2

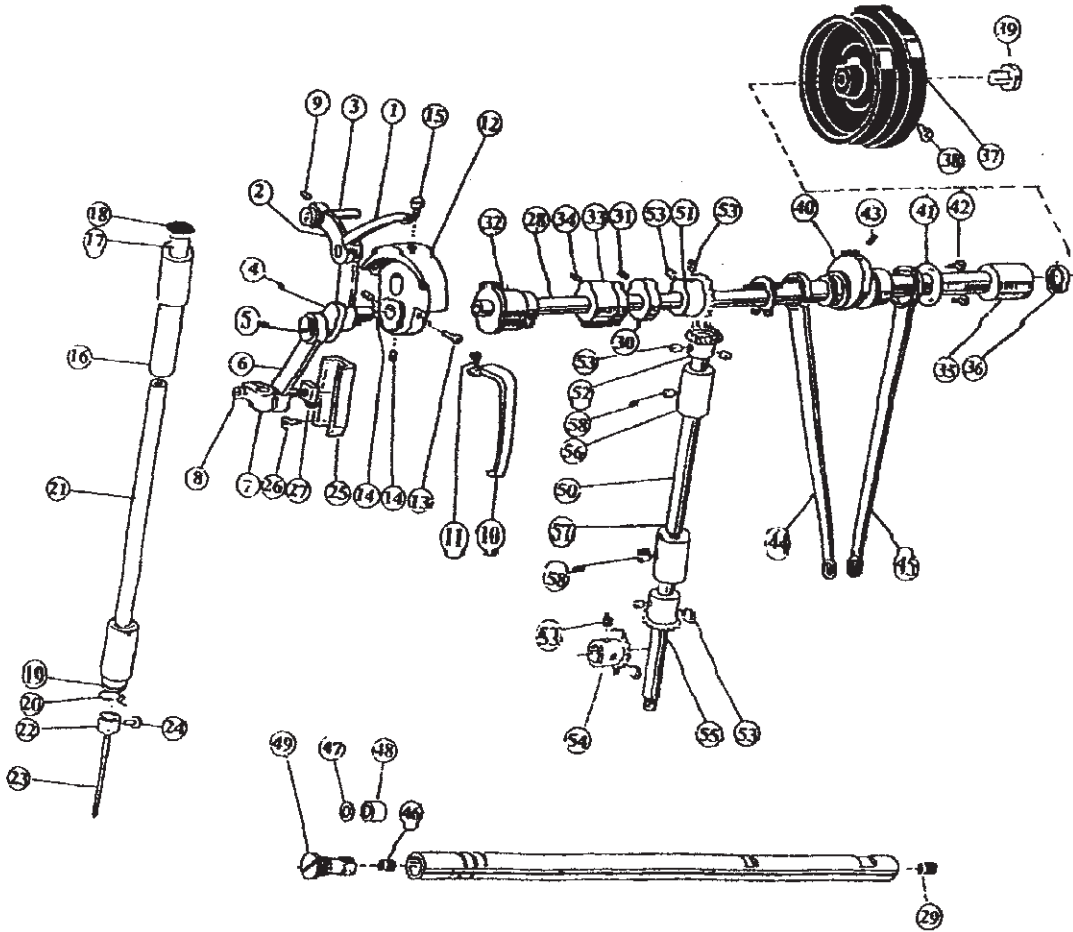

ARM BED AND ITS ACCESSORIES

No.	Ref. No.	Description	M	H	B
1	12H1-001A	Arm	1	1	1
2	12H1-004	Trade mark plate	1		
2	13H1-002	Trade mark plate		1	
2	14H1-001	Trade mark plate			1
3	GB827-86	Trade mark plate rivet	2	2	2
4	GB93-76	Spring washer	2	2	2
5	12H1-005A1	Face plate	1	1	1
6	12H1-005A2	Gasket for face plate	1	1	1
7	72T1-004C3	Rubber plug(ϕ 19)	1	1	1
7	72T1-004C3	Rubber plug(ϕ 19)	1	1	1
8	72T1-004C4	Rubber plug(ϕ 11.8)	1	1	1
8	72T1-004C4	Rubber plug(ϕ 11.8)	1	1	1
8	72T1-004C4	Rubber plug(ϕ 11.8)	1	1	1
9	22T1-003C5	Thread guide on face plate	1	1	
9	74T1-004C1	Thread guide on face plate			1
10	22T1-003C6	Thread guide screw	1	1	1
10	22T1-003C6	Thread guide screw	1	1	1
11	72T1-016	Face plate screw	3	3	3
12	12H1-006B1	Arm side cover	1	1	1
13	12H1-006B2	Gasket for arm side cover	1	1	1
14	72T1-017	Screw	8	8	8
15	12H1-007C1	Oil check window	1	1	1
16	22T1-009E1	Screw type tension stud	1	1	1
17	22T1-009E2	Spring for pre-tension	1	1	1
18	22T1-009E3	Disk for pre-tension	2	2	2
19	22T1-009E4	Space for pre-tension	1	1	1
20	GB896-76	Stop ring	1	1	1
21	22T1-009E5	Pre-tension thread guide	1	1	1
22	22T1-010	Three-hole thread guide	1	1	1
23	22T1-011	Set screw	1	1	1
24	22T1-012F1	Thread tension stud	1	1	1
25	72T1-007F1	Thumb nut	1	1	1
26	22T1-012F3	Thread tension spring	1		
26	83T1-003C2	Thread tension spring		1	1
27	72T1-007F2	Thread tension disc	1	1	1
28	72T1-007F5	Thread tension disc	2	2	2
29	22T1-012F6	Thread take-up spring	1		
29	83T1-003C1	Thread take-up spring		1	1
30	72T1-007F3	Thread tension regulating bushing	1	1	1
31	22T1-012F8	Set screw	1	1	1
32	22T1-012F9	Thread tension releasing pin	1	1	1
33	22T1-012F10	Stop disc	1	1	1
34	22T1-012F11	Rubber ring	1	1	1
35	72T1-008	Set screw	1	1	1
36	22T1-014	Thread guide at ram center	1	1	
36	74T1-005	Thread guide at ram center			1
37	72T1-009	Rubber plug(ϕ 8.8)	2	2	2
38	72T1-010	Rubber plug(ϕ 27)	1	1	1
39	72T1-011	Rubber plug(ϕ 5.7)	2	2	2
40	72T1-012	Needle plate	1		
40	73T1-003	Needle plate		1	1
41	72T1-019	Needle plate screw	2	2	2
42	22T1-021G1	Slide plate	1	1	1
43	22T1-021G2	Slide plate spring	1	1	1
44	22T1-021G3	Screw	2	2	2
45	22T1-022	Leg	3	3	3
46	72T1-014	Cloth guide plate	1	1	1
47	72T1-013	Screw	2	2	2

No.	Ref. No.	Description	M	H	B
1	22T2-001A1a2	Thread take-up lever	1	1	
1	74T2-001A1a2	Thread take-up lever			1
2	22T2-001A2	Thread take-up lever link	1	1	
2	11H2-001A1b1	Thread take-up lever link			1
3	22T2-001A3	Hinge pin	1	1	1
4	72T2-001A2	Thread take-up crank	1		
4	83T7-001A2a2	Thread take-up crank		1	1
4	22T2-001A5	Needle bearing	2	2	2
5	22T2-001A6	Screw(left-handed)	1	1	1
6	72T2-001A7b1	Needle bar link	1	1	1
7	22T2-001A8	Needle bar adaptor	1	1	1
8	22T1-003C6	Set screw	1	1	1
9	22T2-002	Set screw	1	1	1
10	82T7-003	Thread take-up guard	1	1	
10	74T2-002	Thread take-up guard			1
11	72T2-003	Set screw	1	1	1
12	82T2-002B1	Needle bar crank	1		
12	83T2-002A1	Needle bar crank		1	1
13	22T2-006	Set screw	1	1	1
14	72T2-004B2	Set screw	2	2	2
15	22T2-007	Set screw	1	1	1
16	22T2-008	Needle bar bushing(upper)	1	1	1
17	22T2-010	Felt plug	1	1	1
18	72T2-005	Rubber plug	1	1	1
19	72T2-006	Needle bar bushing(lower)	1	1	1
20	72T2-007	Thread guide	1	1	1
21	72T2-008	Needle bar	1		
21	73T2-002	Needle bar		1	1
22	22T2-015	Thread guide for needle bar	1		
22	73T2-003	Thread guide for needle bar		1	1
23	22T2-016	Needle	1		
23	73T2-004	Needle		1	1
24	22T2-017	Needle clamp screw	1	1	1
25	22T2-018	Guide for slide block	1	1	1
26	22T2-019	Set screw	2	2	2
27	22T2-020	Slide block	1	1	1
28	82T2-001A1a1	Arm shaft	1	1	1
29	22T3-001A2	Rubber plug(ϕ 7.4 x 10)	2	2	2
30	22T6-005B1	Collar for arm shaft	1	1	1
31	22T3-002B2	Set screw	2	2	2
32	82T1-001A8	Arm shaft bushing(left)	1	1	1
33	22T3-004	Arm shaft bushing(middle)	1	1	1
34	22T2-002	Set screw	1	1	1
35	72T3-002	Arm shaft bushing (right)	1	1	1
36	72T3-003B	Oil seal	1	1	1
37	22T3-007C1	Balance wheel	1	1	1
38	22T3-007C2	Set screw	2	2	2
39	22T3-008	Screw	1	1	1
40	82T2-003C1a1	Feed and feed lifting eccentric	1		
40	83T2-002B1a1	Feed and feed lifting eccentric		1	1
41	82T2-003C1a2	Washer	1	1	1
42	82T2-003C1a3	Set screw	3	3	3
43	22T2-002	Set screw	2	2	2
44	22T3-009D1c	Crank rod for feed lifting rock shaft	1	1	1
45	82T2-003C1a5	Crank rod for feed rock shaft	1	1	1
46	82T2-001A3	Felt plug	1	1	1
47	82T2-002A2a2	Oil seal	1	1	1
48	82T2-001A2a3	Rubber seal	1	1	1
49	82T2-001A2a1	Oil adjusting bar	1	1	1
50	22T3-010E1	Vertical shaft	1	1	1
51	22T1-010E2a1-2	Bevel gear for arm shaft	1	1	1
52	22T3-010E2a2-2	Bevel gear for vertical shaft(upper)	1	1	1
53	22T2-005B3	Set screw	8	8	8
54	22T3-010E2b1-2	Bevel gear for hook shaft	1	1	1
55	22T3-010E2b2-2	Bevel gear for vertical shaft(lower)	1	1	1
56	22T3-011	Vertical shaft bushing(upper)	1	1	1
57	22T3-011	Vertical shaft bushing(lower)	1	1	
57	74T3-001	Vertical shaft bushing(lower)			1
58	22T2-002	Set screw	2	2	2

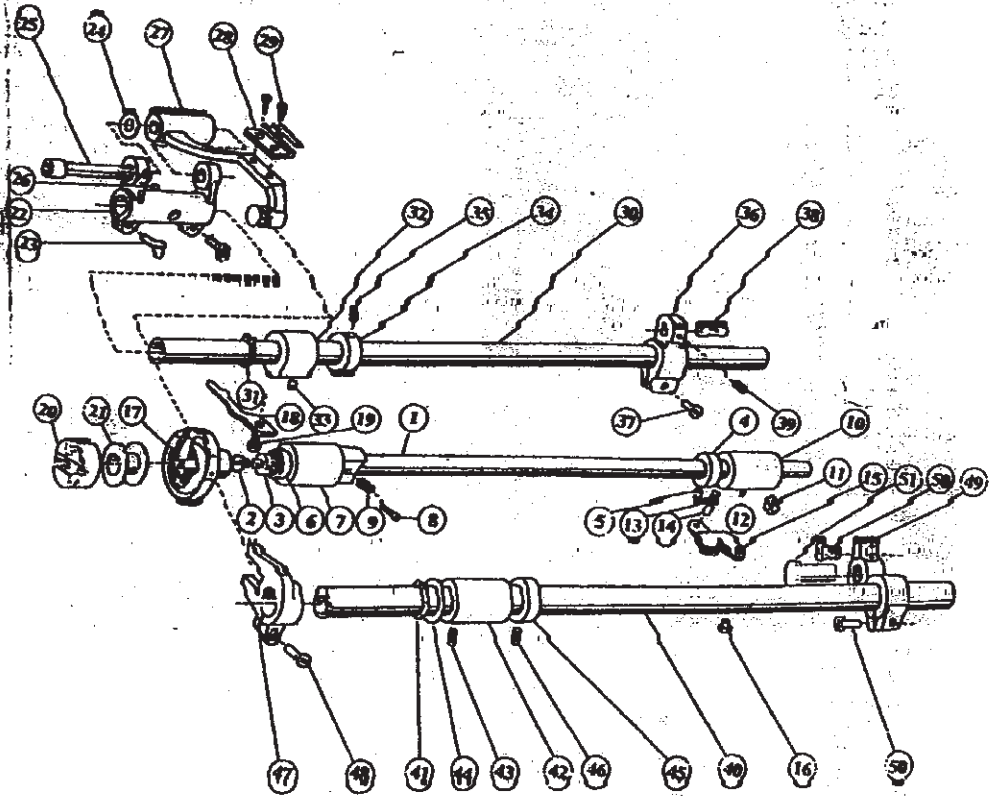

3. FEEDING AND FEED LIFTING. ROTATING HOOK MECHANISM

No.	Ref. No.	Description	M	H	B
1	72T4-001A1	Rotating hook shaft	1	1	
1	72T4-001A1	Rotating hook shaft			1
2	22T4-001A1a1	Filter screw	1	1	1
3	22T4-001A1a2	Filter	1	1	1
4	72T4-002B7	Collar for rotating hook shaft	1	1	1
5	72T4-002B2	Set screw	2	2	2
6	82T4-003	Oil seal for rotating hook shaft	1	1	1
7	82T4-001A4	Hook shaft bushing(left)	1	1	1
8	72T4-003	Oil adjusting screw	1	1	1
9	22T4-006	Spring for oil adjusting-	1	1	1
10	72T4-008C1	Hook shaft bushing(right)	1	1	1
11	22T2-002	Set screw	1	1	1
12	22T4-007C2	Oil pipe for hook shaft bushing	1	1	1
13	72T4-010	Plunger	1	1	1
14	72T4-011	Plunger spring	1	1	1
15	22T4-010	Guide plate	1	1	
15	84T12-001	Guide plate			1
16	22T5-001A4	Set screw	1	1	1
17	22T4-012E	Rotating hook complete	1		
17	83T4-001A	Rotating hook complete		1	
17	84T4-003B	Rotating hook complete			1
18	72T4-005	Rotating hook positioner	1		
18	73T4-002	Rotating hook positioner		1	
18	72T4-004	Rotating hook positioner			1
19	22T4-015	Screw	1	1	1
20	22T4-016F	Bobbin case	1		
20	83T4-002B	Bobbin case		1	
20	84T4-003	Bobbin case			1
21	22T4-017	Bobbin	1	1	
21	74T4-006	Bobbin			1
22	22T6-001A1a	Feed rock shaft crank	1	1	1
23	22T6-001A1b	Screw	2	2	2
24	22T6-001A6	Washer	1	1	1
25	82T9-002A4	Shaft for feed bar(eccentric)	1	1	1
26	22T2-019	Screw	1	1	1
27	82T9-002A3a1	Feed bar	1	1	1
28	22T6-001A3	Feed dog	1	1	1
29	22T6-001A4	Screw	2	2	2
30	72T6-005	Feed rock shaft	1	1	1
31	GB894-76	C-type stop ring	1	1	1
32	22T6-004	Feed rock shaft bushing	1	1	1
33	72T4-002B2	Set screw	1	1	1
34	22T6-005B1	Collar	1	1	1
35	22T3-002B2	Screw	2	2	2
36	82T2-003C1a7	Feed rock shaft crank(right)	1		1
36	82T2-002B1a2	Feed rock shaft crank(right)		1	1
37	82T2-003C1a6	Screw	1	1	1
38	82T2-003C1a10-1	Feed rock shaft crank pin	1	1	1
39	82T2-003C1a8	Screw	1	1	1
40	82T10-001A2	Feed lifting rock shaft	1	1	1
41	GB894-76	C-type stop ring	1	1	1
42	22T6-012	Feed lifting rock shaft bushing	1	1	1
43	22T2-002	Screw	1	1	1
44	22T6-013	Washer	1	1	1
45	22T6-005B1	Collar for feed lifting rock shaf	1	1	1
46	22T3-005B2	Screw	2	2	2
47	82T10-001A1a1	Feed lifting rock shaft crank(left)	1	1	1
48	22T6-008D3	Screw	1	1	1
49	82T10-002B1	Feed lifting rock shaft crank(right)	1		
49	72T6-003C1	Feed lifting rock shaft crank(right)		1	1
50	22T6-001A1b	Set screw	2	2	2
51	22T6-007	Hinge pin	1	1	1

4

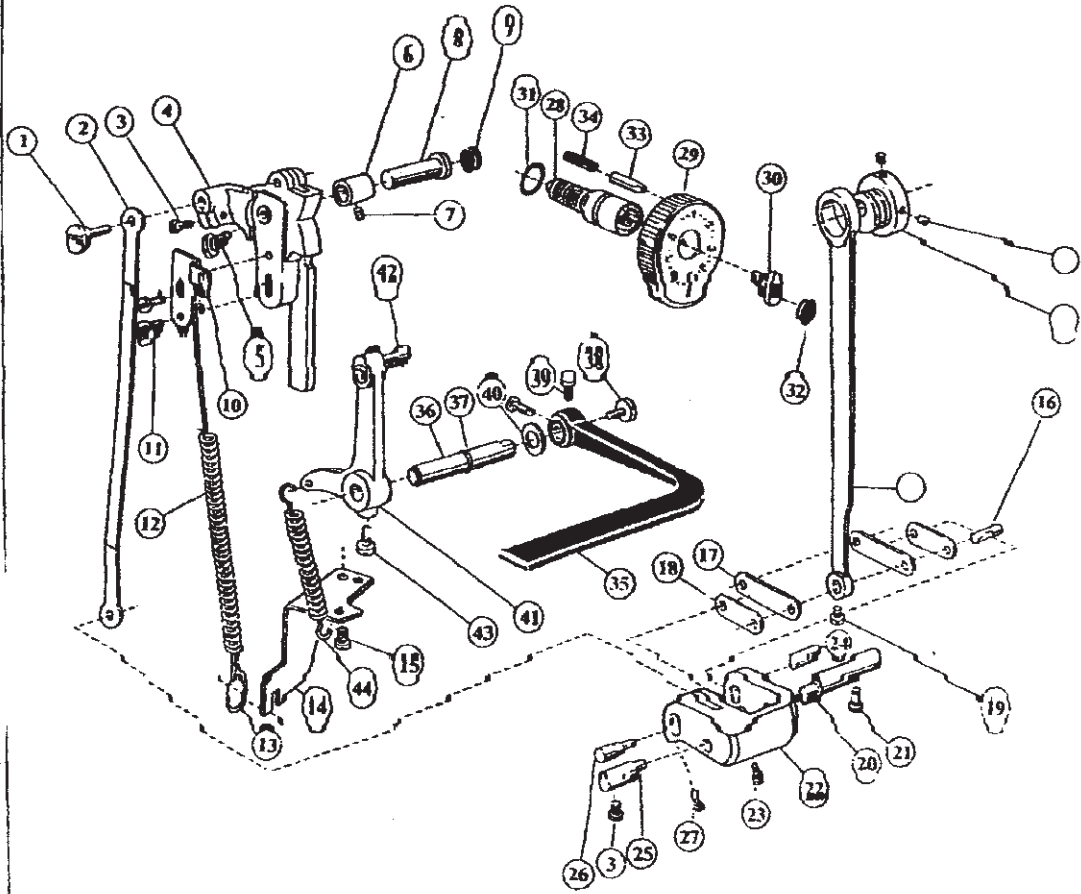

9. STITCH LENGTH REGULATING MECHANISM

No.	Ref. No.	Description	M	H	B
1	82T2-006	Connecting rod stud	1	1	1
2	82T2-003C1a4	Feed connecting link	1	1	1
3	22T6-008D3	Screw	1	1	1
3	22T6-008D3	Screw	1	1	1
4	12H4-001A1	Feed regulator	1		
4	13H4-001A1	Feed regulator		1	1
5	22T5-010D4	Screw	1	1	1
6	82T1-001A5	Feed regulator bushing	1	1	1
7	22T2-002	Screw	1	1	1
8	22T5-004	Hinge pin for feed regulator	1	1	1
9	72T5-003	Rubber plug(ϕ 20 x 4)	1	1	1
10	12H4-002	Spring retainer	1	1	1
11	22T2-019	Screw	2	2	2
12	12H4-005	Coil spring	1	1	1
13	83T2-003C5	Spring retainer	1	1	1
14	83T5-001	Spring holder	1	1	1
15	22T5-001A4	Screw	1	1	1
16	82T2-003C1a10-2	Link stud	1	1	1
17	82T2-003C1a9-2	Link(long)	2		
17	83T2-002B1a3	Link(long)		2	2
18	82T2-003C1a9-1	Link(short)	2	2	2
19	82T2-003C1a8	Set screw	1	1	1
20	82T2-004	Feed regulator shaft(right)	1	1	1
21	22T6-008D3	Set screw	1	1	1
22	82T2-003C1a15	Stitch length adjusting crank	1	1	1
23	82T2-003C1a12	Set screw	1	1	1
24	82T2-003C1a13	Link stud	1	1	1
25	82T2-005	Feed regulator shaft(left)	1	1	1
26	82T2-003C1a14	Link stud	1	1	1
27	82T2-003C1a11	Screw	1	1	1
28	22T5-006C1	Feed regulator screw bar	1	1	1
29	72T5-004B1	Dial	1		
29	72T5-003C2	Dial		1	1
30	22T5-006C3	Screw	1	1	1
31	22T5-006C4	O-ring	1	1	1
32	72T5-005	Rubber plug	1	1	1
33	22T5-008	Stopper pin	1	1	1
34	22T5-009	Spring for stopper pin	1	1	1
35	72T5-006C1	Reverse feed lever	1	1	1
36	22T5-010D2a	Reverse feed lever pin	1	1	1
37	22T5-010D2b	O-ring	1	1	1
38	22T5-010D3	Screw	1	1	1
39	22T5-001A4	Screw	2	2	2
40	22T5-011	Washer	1	1	1
41	12H4-003B1	Reverse feed lever crank	1	1	1
42	22H3-004C1	Reverse feed lever crank pin	1	1	1
43	22T5-013	Screw	1	1	1
44	12H4-004	Spring for feed regulator crank	1	1	1

5

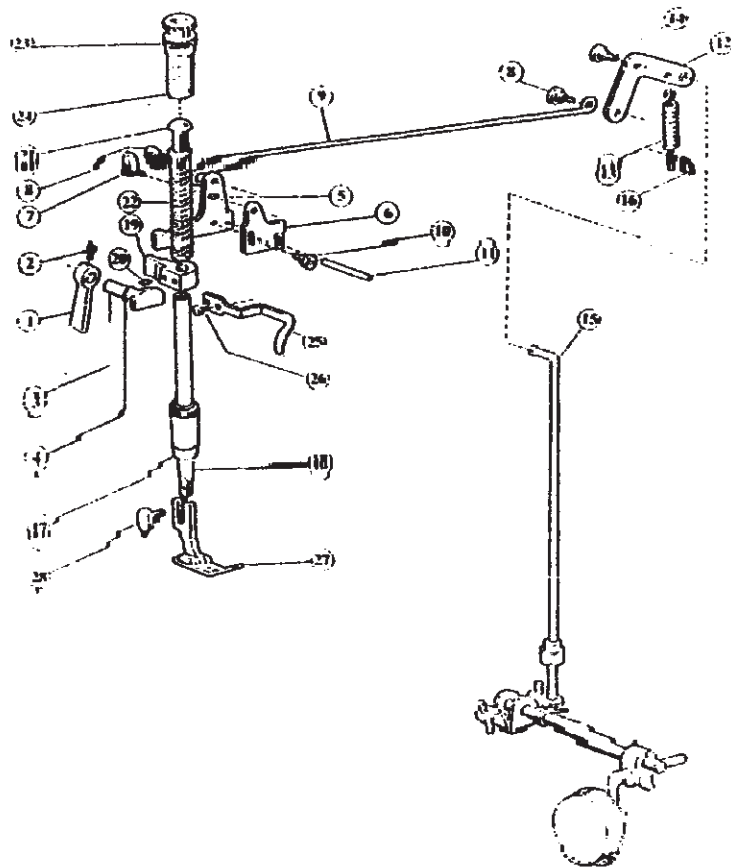

5. PRESSER FOOT MECHANISM

No.	Ref. No.	Description	M	H	B
1	12H5-001A1	Presser bar lifter	1	1	1
2	72T1-017	Set screw	1	1	1
3	12H5-002B1	Presser bar lifting cam	1		
3	13H5-001A1	Presser bar lifting cam		1	1
4	72T7-008	Oil seal for presser bar lifting	1	1	1
5	22T7-004B1a	Knee lifter lever(left)	1	1	1
6	72T7-002B1-1	Tension releasing cam	1	1	1
7	22T7-004B1c	Screw	1	1	1
8	22T7-004B2	Screw	2	2	2
9	22T7-004B3	Knee lifter rod	1	1	1
10	22T7-005	Screw	1	1	1
11	22T7-006	Tension releasing pin	1	1	1
12	22T7-007C1	Knee lifter lever(right)	1	1	1
13	22T7-007C2	Spring for knee lifter lever	1	1	1
14	22T7-005	Screw	1	1	1
15	72T7-003C1	Knee lifter connecting rod	1	1	1
16	22T7-008	Pin for spring	1	1	1
17	72T7-009	Presser bar bushing	1	1	1
18	72T7-011	Presser bar	1	1	1
19	72T8-004C1	Presser bar lifting bracket	1	1	1
20	72T3-005D1a	Screw	1	1	1
21	22T7-012	Presser bar guide	1	1	1
22	22T7-013	Presser bar spring	1	1	1
23	22T7-014E2	Lock nut	1	1	1
24	72T7-006D1	Pressure regulating thumb screw	1	1	1
25	72T7-012	Upper thread guide	1	1	1
26	22T2-004	Screw	1	1	1
27	72T7-007E	Presser foot complete	1	1	
27	11H7-001A	Presser foot complete			1
28	22T7-015	Screw	1	1	1

6

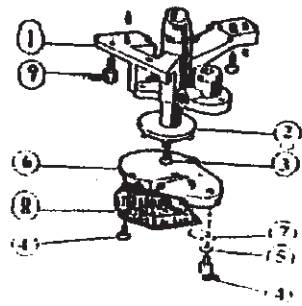
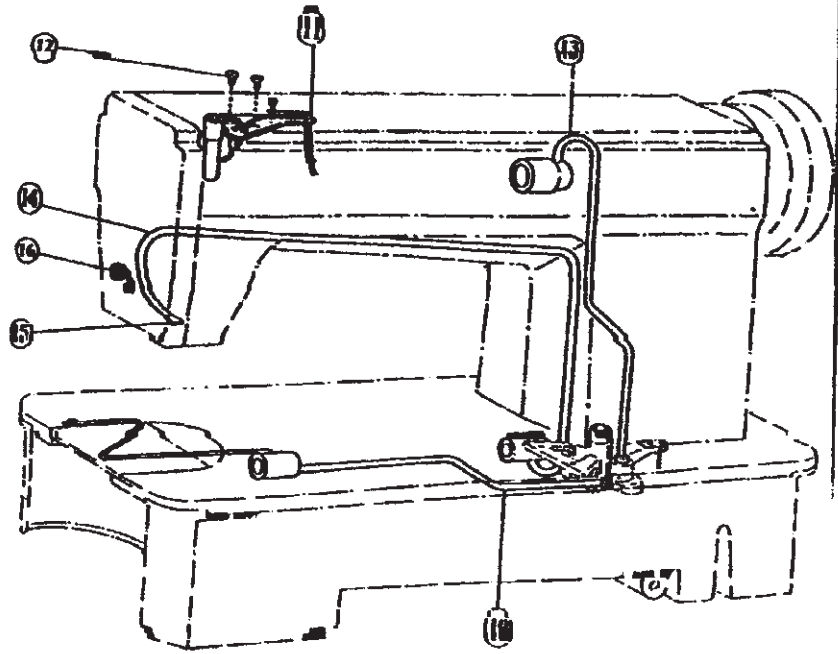

5. LUBRICATION MECHANISM

No.	Ref. No.	Description	M	H	B
1	22T8-001	Oil pump body	1	1	1
2	22T8-002	Oil pump impeller	1	1	1
3	22T8-003	Screw	1	1	1
4	72T8-005	Screw	3	3	3
5	22T8-005	Spring washer	1	1	1
6	22T8-006	Oil pump fitting plate	1	1	1
7	22T8-007	Oil adjusting plate	1	1	1
8	22T8-008A	Oil pump screen complete	1	1	1
9	22T8-009	Screw	3	3	3
10	22T8-010B	Oil pipe for hook shaft	1	1	1
11	72T8-001A	Oil braid fitting plate	1	1	1
12	22T8-011C4	Screw	2	2	2
13	22T8-013D	Oil pipe for arm shaft	1	1	1
14	72T8-002B1	Oil return pipe	1	1	1
15	22T8-015	Felt pouch	1	1	1
16	72T8-006	Piper holder	1	1	1

7

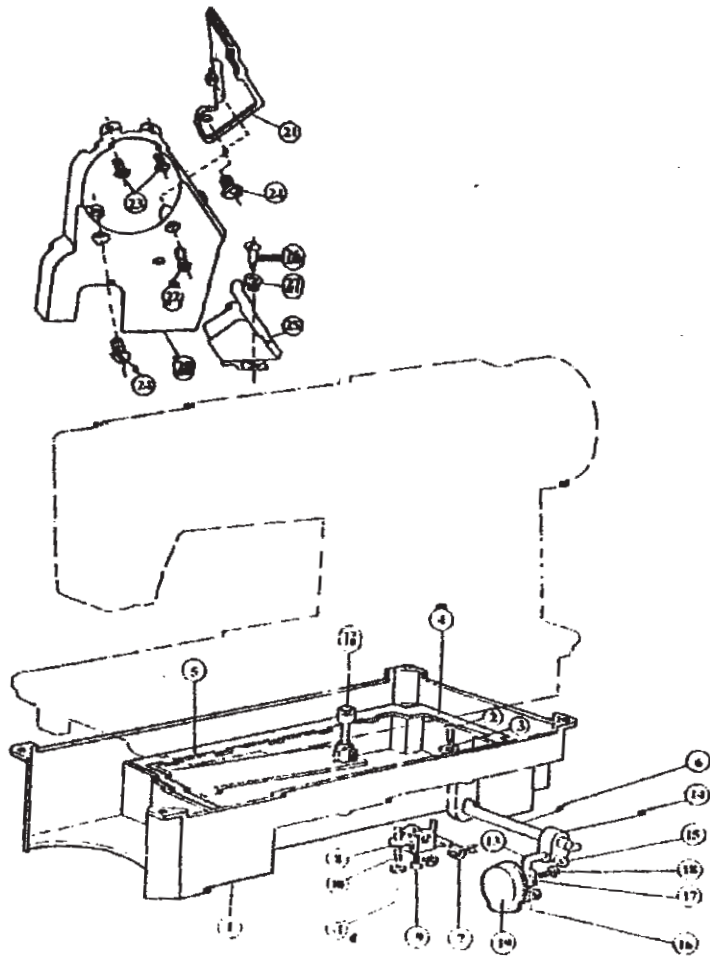

OIL RESERVOIR AND OTHER ACCESSORIES

8

No.	Ref. No.	Description	M	H	B
1	72T9-001A1	Oil reservoir	1	1	1
2	22T9-001A2	Oil drain screw	1	1	1
3	22T9-001A3	Washer	1	1	1
4	22T9-001A4	Gasket for oil reservoir(small)	1	1	1
5	22T9-001A5	Gasket for oil reservoir(big)	1	1	1
6	72T9-016	Hinge pin for knee lifter	1	1	1
7	22T9-001A7	Backspring for knee lifter	1	1	1
8	22T9-001A8	Knee lifter stop bracket	1	1	1
9	22T3-007C2	Screw	1	1	1
10	22T9-001A9	Adjusting screw	2	2	2
11	22T9-001A10	Lock nut	2	2	2
12	22T9-003B1	Knee lifter lifting rod	1	1	1
13	22T9-003B2	Knee lifter bell crank	1	1	1
14	22T9-003B3	Joint for knee lifter bell crank	1	1	1
15	72T9-018	Screw	2	2	2
16	22T9-003B5	Knee lifter plate	1	1	1
17	22T9-003B6	Bracket for knee lifter plate	1	1	1
18	22T9-003B7	Screw	1	1	1
19	22T9-003B8	Pad for knee lifter plate	1	1	1
20	72T9-002B1	Belt guard	1	1	1
21	72T9-002B2a	Belt guard	1	1	1
22	72T9-025	Set screw	1	1	1
23	72T1-017	Screw	2	2	2
24	72T9-028	Screw	2	2	2
25	72T9-002B3	Belt	1	1	1
26	GB99-76	Screw	2	2	2
27	72T9-023	Washer	2	2	2

8

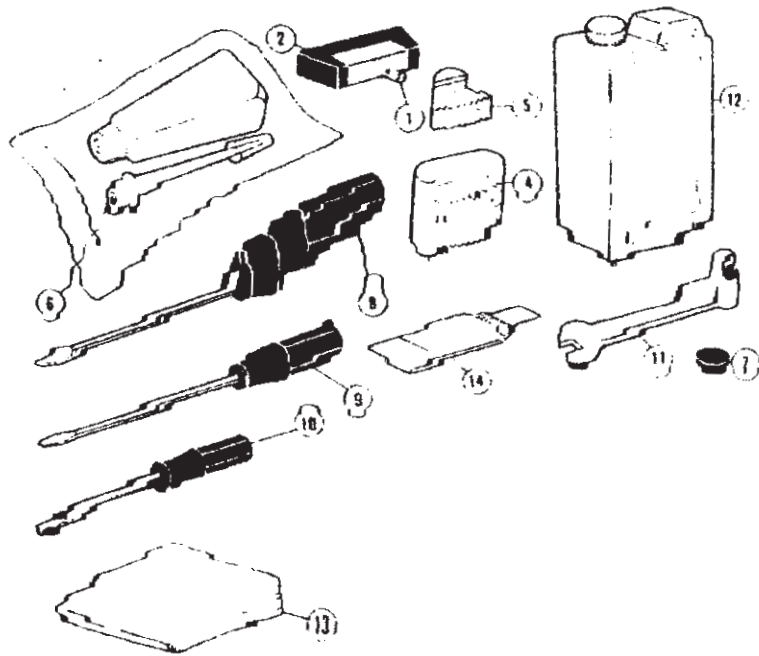

8. OTHER ACCESSORIES

No.	Ref. No.	Description	M	H	B
1	22T9-007F1	Hinge of machine head	2	2	2
2	72T9-004C1	Rubber socket for hinge	2	2	2
4	72T9-005	Rubber cushion(big)	2	2	2
5	72T9-006	Rubber cushion(small)	2	2	2
6	22T9-011	Oiler	1	1	1
7	22T9-012	Magnet	1	1	1
8	72T9-007	Screw driver(long)	1	1	1
9	72T9-020	Screw driver(medium)	1	1	1
10	72T9-021	Screw driver(short)	1	1	1
11	72T9-022	Double-end wrench	1	1	1
12	22T9-017	Oil container	1	1	1
13	72T9-017	Vinyl cover	1	1	1
14	73T9-004	Needle	4	4	4

9

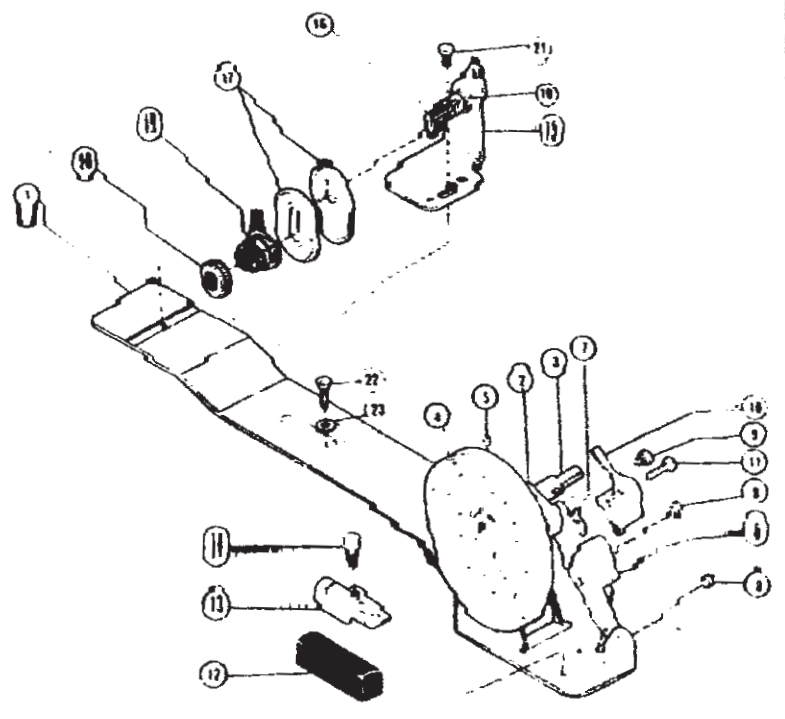

9. BOBBIN WINDER MECHANISM

No.	Ref. No.	Description	M	H	B
1	22T9-006D1	Bobbin winder base	1	1	1
2	22T9-006D2	Bobbin winder arm	1	1	1
	22T9-006D3	Shaft for bobbin winder arm	1	1	1
	22T9-006D4	Spring	1	1	1
3	7F0-022	Bobbin winder spindle	1	1	1
4	22T9-006D6	Bobbin winder pulley	1	1	1
5	22T9-006D7	Screw	1	1	1
6	22T9-006D8	Bobbin winder stop latch lever	1	1	1
7	22T9-006D9	Bobbin winder connecting bar	2	2	2
8	22T9-006D10	Rivet	1	1	1
9	22T9-006D11	Screw	1	1	1
10	22T9-006D12	Bobbin winder stop latch	1	1	1
11	22T9-006D13	Adjusting screw	1	1	1
12	22T9-006D14	Stopper block	1	1	1
13	22T9-006D15	Fixture for stopper block	1	1	1
14	22T9-006D16	Set screw	1	1	1
15	22T9-006D17	Bobbin winder tension bracket	1	1	1
16	22T9-006D18	Bobbin winder tension stud	1	1	1
17	22T9-006D19	Bobbin winder tension disc	2	2	2
18	22T9-006D20	Tension stud bushing	1	1	1
19	22T9-006D21	Bobbin winder tension spring	1	1	1
20	22T9-006D22	Tension stud nut	1	1	1
21	22T9-006D23	Tension bracket screw	1	1	1
22		Wood screw	2	2	2
23		Washer	2	2	2