

ARTISAN®



797 AB

Series
Sewing Machines

Operators Manual
and
Spare Parts List

1. MAIN SPECIFICATIONS

- | | |
|-----------------------|----------------------------------------------------------|
| 1. Function: | Stitch Used to Sew Fabrics and Leather. |
| 2. Max. Sewing Speed: | Up to 2000 SPM |
| 3. Stitch Length: | 0 - 6 mm |
| 4. Needle Bar Stroke: | 35 mm |
| 5. Presser Bar Lift: | 6 mm by hand lever, 15 mm by Knee Lift |
| 6. Needle: | 135 x 17 (Fabric) 135 x 15 (Leather) Size 22 |
| 7. Lubrication: | Automatic with pressure oil pump and some manual points. |
| 8. Hook: | Big Bobbin HD Rotating Hook |
| 9. Bobbin: | "W" size Big Bobbin |

2. INSTALL THE MOTOR (Fig.1)

Align Motor Pulley Groove (B) and Balance Wheel Groove (A) by moving the motor leftward or rightward.

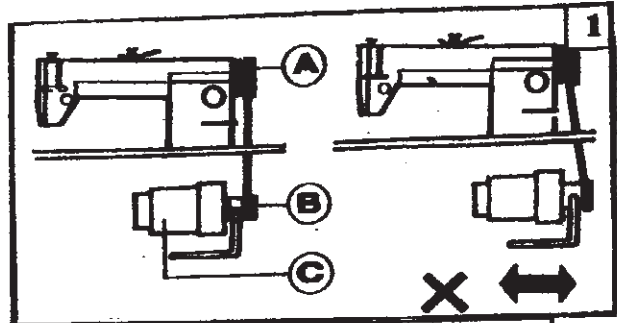

3. CONNECT THE CLUTCHLEVER WITH THE PEDAL (Fig. 2)

- 1) The optimum tilt angle of Pedal (A) is approximately 15 deg.
- 2) Adjust Clutch Cover (D) so that Clutch-Lever (C) and Draw Bar (B) run in line.
- 3) The balance wheel should rotate counter-clockwise when viewed from the outside of Balance Wheel (G). The direction of the motor pulley rotation can be reversed by reversing (turning over 180 deg.) the power plug of the motor.
- 4) Adjust the tension of V-belt (F) by turning Motor Vertical Position Screw (E). The proper tension of the V-belt is a slack of 10-20mm when the belt is depressed at the center of the belt by finger.

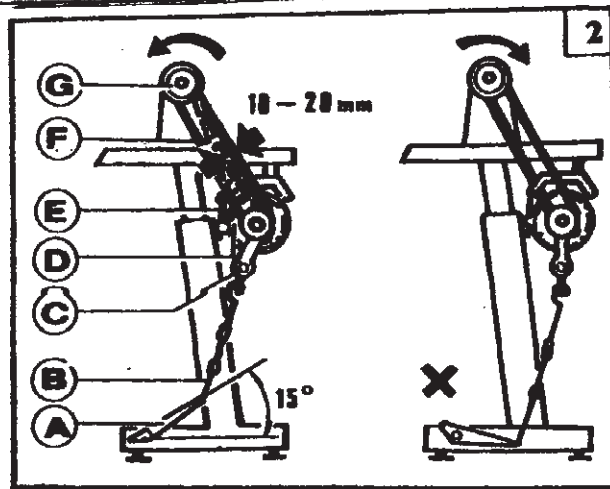

4. PREPARATION AND LUBRICATION (Fig.3)

1) Cleaning the machine

Before leaving the factory, the machine parts are coated with rust-preventive grease, which may be hardened and contaminated by dust during storage and shipment. This grease must be removed with gasoline.

2) Examination

Though every machine is confirmed by strict inspection and test before leaving the factory, the machine parts may be loose or deformed after long distance transportation with jolt. A thorough examination must be performed after cleaning the machine. Turn the balance wheel to see if there is running obstruction, parts collision, uneven resistance or abnormal noise. If these exist, adjustment must be made accordingly before run-in operation.

3) Oiling

(1) Required amount of oil

Line (A) on the oil reservoir: Max. oil level.

Line (B) on the oil reservoir: Min. Oil level

If oil level goes down under Line (B), oil cannot be distributed to each part of the machine, thus causing the parts a seizure.

(2) Replenishing

Always use only No. 18 special machine oil for high speed sewing. Be sure to replenish oil to Line (A) before starting operation.

(3) Replacing oil

To replace oil, remove Screw (C) to drain oil. After completely draining off oil, clean the oil reservoir and securely tighten Screw (C), then fill the reservoir with fresh oil.

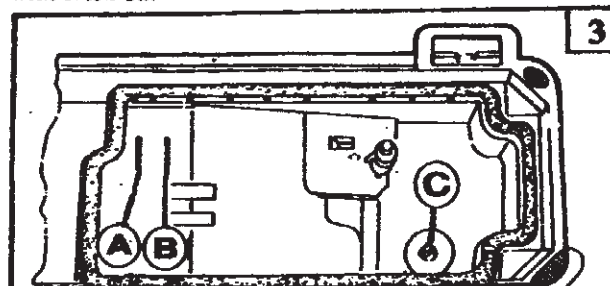

5. REPLACE NEEDLES (Fig.4)

Turn the balance wheel to lift needle bar to the upper end of its stroke. Loosen Needle Clamp Screw A. While keeping the long groove of the needle leftward fully insert the needle shank up to the bottom of the needle socket. Then tighten Needle Clamp Screw A.

Note: Fig. (b): insufficient insertion.

Fig. (c): wrong direction of long groove.

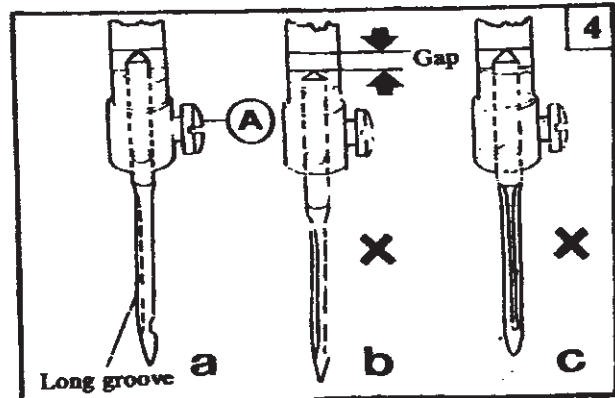

6. NEEDLE, THREAD AND MATERIAL TO BE SEWN

Needle Size	Thread Number	Material
No.14	No.60-No.65	Cotton, Woolen
No.16	No.30-No.50	Muslin, Woolen, Tarpaulin, Thin Leather
No.22		Medium leather, Canvas

7. RUN-IN OPERATION (Fig. 5)

Run-in operation is required for a new sewing machine, or a sewing machine left out of operation for a considerable length of time.

1) Remove Red Rubber Plugs (A) on the top of the arm and replenish sufficient amount of oil.

2) Lift Presser Foot (B)

3) Run the machine at a low speed (1000-1500rpm) to check oil distributing condition through Oil Check Window (C).

4) Perform run-in operation at 1000-1500 spm for 30 minutes. After a lapse of one month of service during which the working speed is increased gradually and the machine runs sufficiently well, the high speed 2000spm can be adopted according to the nature of the work.

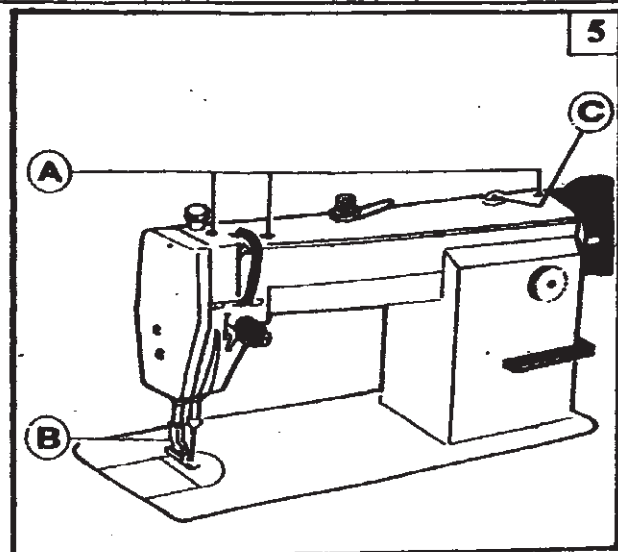

8. THREADING (Fig. 6)

To thread the needle thread, raise needle bar to the upper end of its stroke, lead the thread from spool and perform threading as shown in Fig. 6. To draw the bobbin thread; hold the end of the needle thread and turn the balance wheel to lower the needle bar and then to lift it to its highest position. Pull the needle thread and the bobbin thread is drawn up. Put the ends of needle thread and bobbin thread forward under presser foot.

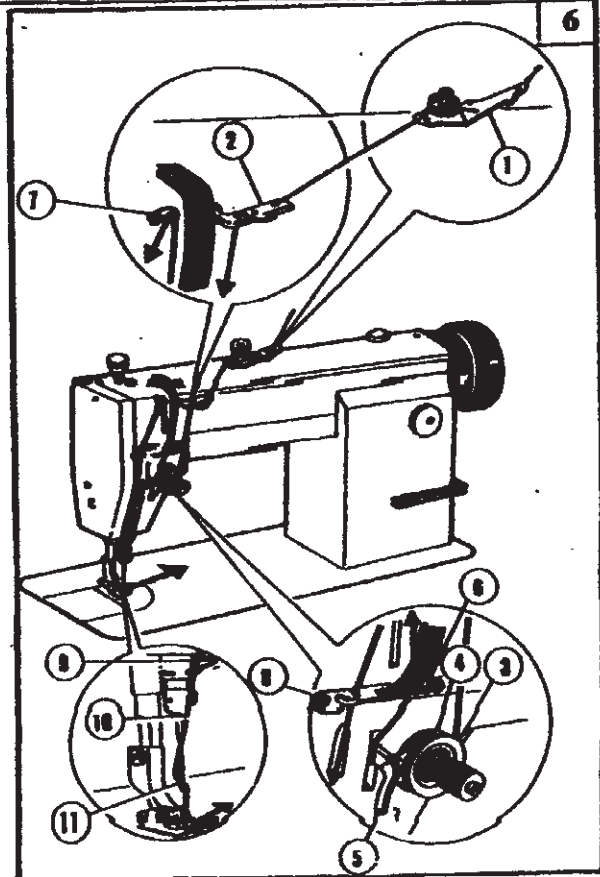

9. WINDING ADJUSTMENT (Fig. 7)

1) The wound bobbin thread should be neat and tight, if not, adjust the winding tension by turning Tension Stud Nut (A) of bobbin winder tension bracket.

Note: nylon or polyester thread should be wound with little tension, otherwise, Bobbin (D) might break or deform.

2) When the wound thread layer does not present a cylindrical shape as shown in Fig. 7 (a), loosen Set Screw (B) of bobbin winder tension bracket and slide Bracket (C) leftward or rightward. If thread is wound as shown in Fig. 7 (b), move the bracket rightward, but if thread is wound as shown in Fig. 7 (c), move the bracket leftward.

After adequately positioning the bracket, tighten Set Screw (B).

3) Do not overfill the bobbin. The optimum length of thread will fill about 80% of bobbin capacity. This can be adjusted by Adjusting Screw (E) of bobbin winder stop latch.

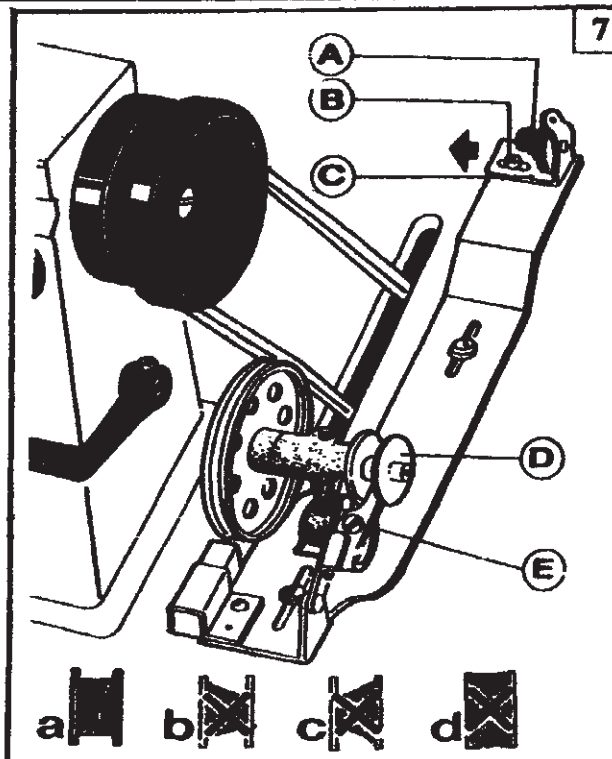

10. SET STITCH LENGTH AND REVERSE FEEDING (Fig. 8)

- 1) Stitch length can be set by turning Dial (A).
- 2) The figures on Face (B) of dial show stitch length in mm.
- 3) Reverse feeding starts when Reverse Feed Lever (C) is depressed, and the machine will feed forward again if Reverse Feed lever (C) is released.

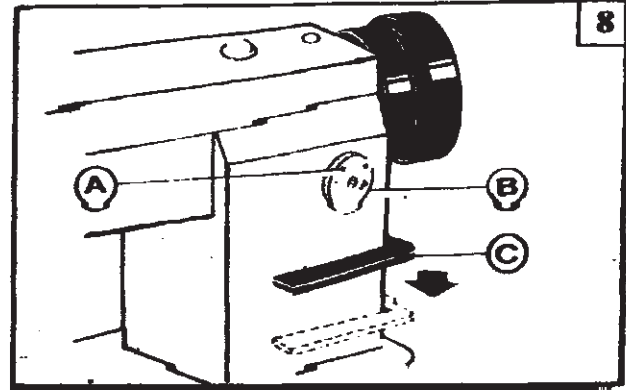

11. POSITION PRESSER BAR (Fig. 9)

- 1) Loosen Lock Nut (E) and Pressure Regulating Thumb Screw (A).
- 2) Remove rubber plug from Face Plate (B).
- 3) Loosen Screw (C) and adjust the position of Presser Bar, till the presser foot is 6mm above the throat plate with the presser foot lifted to its highest.
- 4) Tighten Screw (C) and put in the rubber plug.
- 5) Tighten Pressure Regulating Thumb Screw (A) and Lock Nut (E).

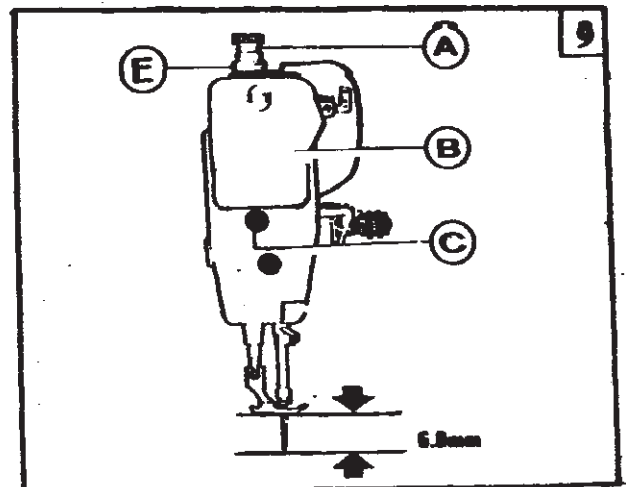

12. ADJUST THE PRESSURE OF PRESSER FOOT (Fig. 10)

Pressure of presser foot is to be adjusted in accordance with thickness of materials to be sewn.

First loosen Lock Nut (A). For heavy materials, turn the pressure regulating thumb screw as shown in Fig. 10 (a) to increase the pressure, while for light materials, turn the pressure regulating thumb screw as shown in Fig. 10 (b) to decrease the pressure. Then tighten Lock Nut (A).

The pressure of presser foot is recommended to be less as long as normal feeding is ensured.

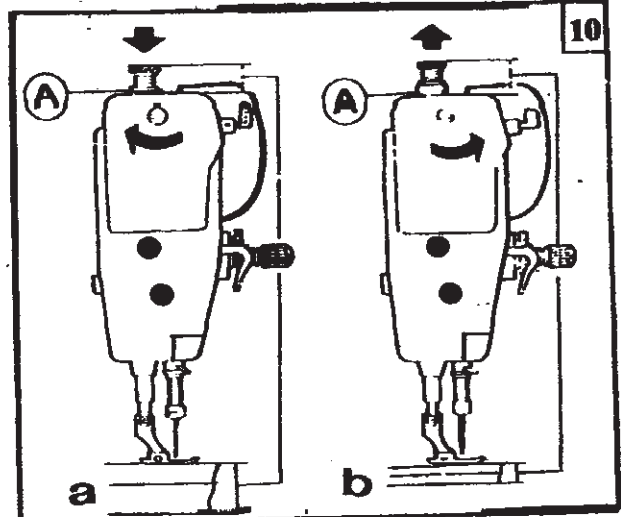

13. ADJUST THREAD TENSION (Fig. 11, 12)

In principle, thread tension is to be adjusted in accordance with materials, thread and other factors.

In practice, thread tension is adjusted according to the stitches obtained. The needle thread tension should be adjusted with reference to the bobbin thread tension. Turn Tension Spring Regulating Screw (A) of bobbin case clockwise for more tension, or turn the screw counter-clockwise for less tension.

It is common practice to test the bobbin thread tension as shown in Fig. 12. Hold the end of the thread from delivery eye. If the bobbin case is falling slowly, the proper tension is obtained. The needle thread tension can be adjusted by setting (1) the thread take-up spring tension, (2) the thread take-up spring stroke and (3) tension spring. All these adjustments will be described in the following.

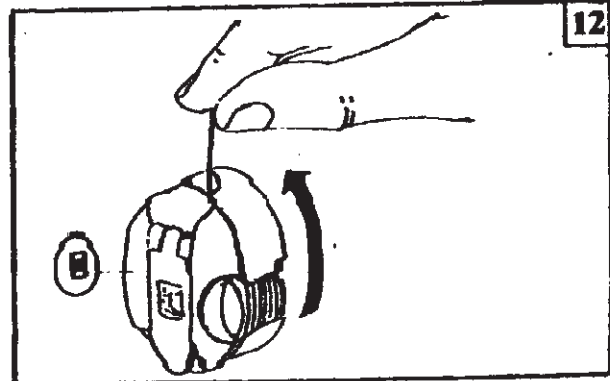
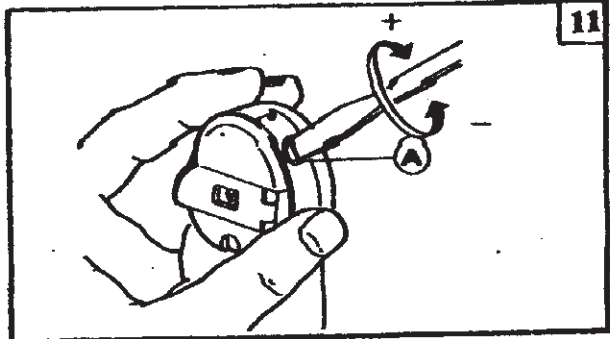

14. ADJUST THREAD TAKE-UP SPRING (Fig. 13, 14)

1) Adjusting the thread take-up spring tension

Loosen Set Screw (A), turn Tension Stud (B) clockwise to increase the spring tension, or turn the stud counter-clockwise to decrease the spring tension. After the adjustment, be sure to tighten Set Screw (A). The thread take-up spring tension should be about 30g. To attain this, first loosen Set Screw (A), turn Tension Stud (B) counter-clockwise to decrease the tension of Thread Take-up Spring (C) to zero, then turn Tension Stud (B) clockwise until Spring (C) comes to the notch of thread tension regulating bushing, and again turn Tension Stud (B) halfway back (counter-clockwise) after the adjustment, tighten Set Screw (A).

2) Adjusting the thread take-up spring stroke

Loosen Set Screw (B), turn Stud (C) clockwise to increase the stroke or turn Stud (C) counter-clockwise to decrease the stroke. After the adjustment, tighten Set Screw (B).

Before leaving the factory, the thread take-up spring has properly been adjusted. Readjustment is needed only in the case of special material or special thread.

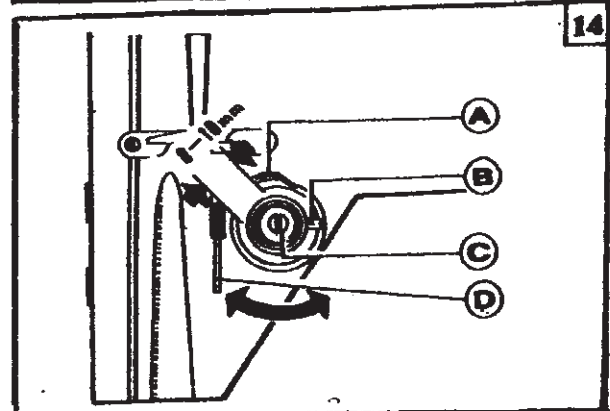
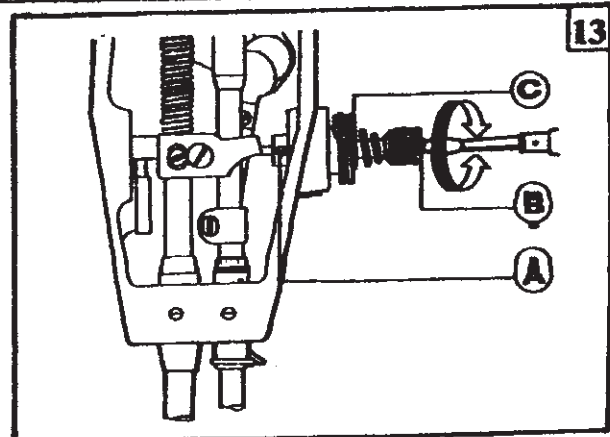

15. ADJUST THREAD GUIDE AND THREAD TENSION (Fig.15,16)

The position of the thread guide affects stitch tightness and therefore must be adjusted according to sewing materials and sewing conditions.

	1	2	3
Thread guide position	Leftward	Center	Rightward
Material weight	Heavy	Medium	Light

Fig. 15 shows different stitch forms. Normal stitch form should be as shown in Fig. 15 (a). When abnormal stitches cause puckering and thread breakage, the tension of needle thread and bobbin thread must be adjusted accordingly.

1) In case needle thread tension is too strong or bobbin thread tension is too weak, as shown in Fig. 15 (b), turn the thumb nut counterclockwise to decrease the needle thread tension, or tighten the tension spring regulating screw of bobbin case to increase the bobbin thread tension (See Fig. 16)

2) In case needle thread tension is too weak or bobbin thread tension is too strong, as shown in Fig. 15 (c), turn the thumb nut clockwise to increase the needle thread tension, or loosen the tension spring regulating screw of bobbin case to decrease the bobbin thread tension.

3) In case of the stitch forms as shown in Fig. 15 (d) and (e), adjustments can be made with reference to the above means.

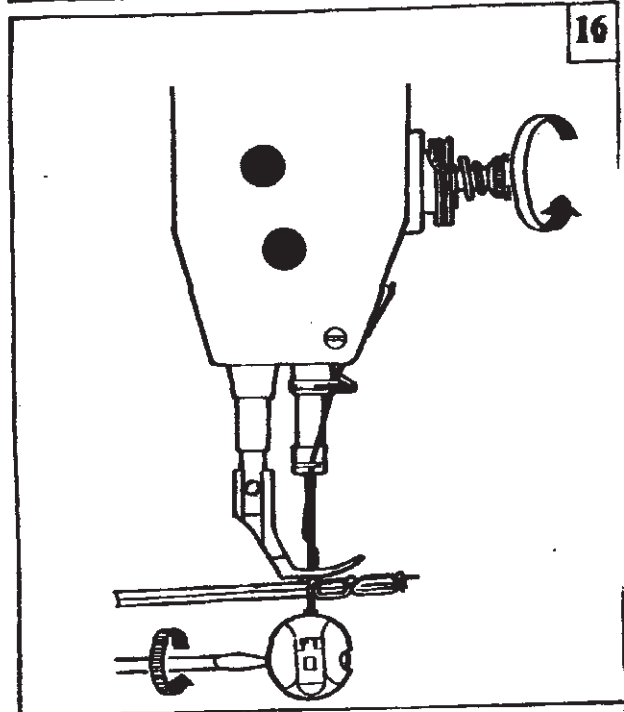
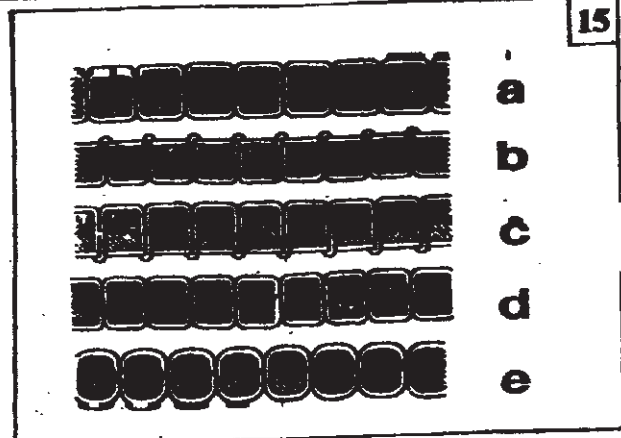

16. TIME NEEDLE TO ROTATING HOOK (Fig. 17,18,19,20)

A. Adjusting the needle position (See Fig.17)

1) Turn balance wheel by hand to bring Needle Bar (C) to the lowest position of its stroke.

2) Remove rubber plug from Face Plate (A)

3) Loosen Set Screw (B) of needle bar adaptor.

4) Move Needle Bar (C) vertically to adjust needle timing.

5) After the adjustment, tighten Set Screw (B) and put in the rubber plug. The standard needle timing (See Fig. 18) is to align Timing Mark (B) on the needle bar and the bottom of Needle Bar Bushing (A) and meanwhile align the Inner Surface (E) of the hook and the center of Needle Eye (D) when the needle bar gets down to its lowest position.

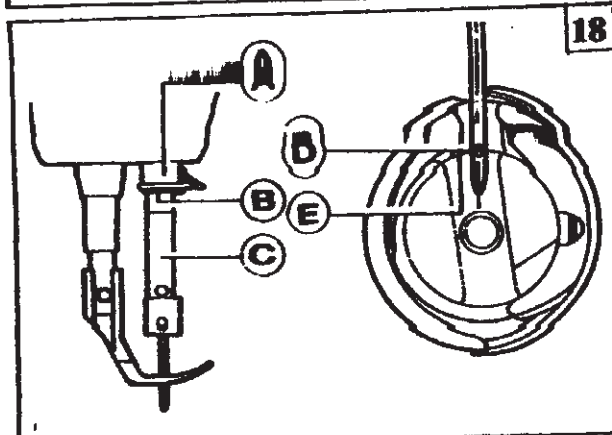
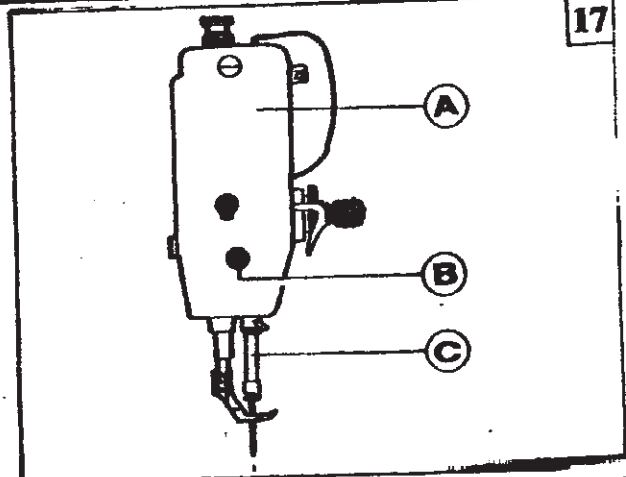

B. Adjusting the hook point timing

Timing of needle motion to rotating hook motion has a great effect on sewing performance. The standard hook point timing (See Fig.19) is to align Hook Point (D) and Needle Centerline (C) when Needle Bar (B) is lifted by 2.4mm from the lower end of its stroke. (2.4 mm suitable for type B and type C). Besides, Hook Point (D) should be 1.0-1.5mm above the upper end of needle eye (E).

When adjusting the hook point timing, also notice that the clearance between the bottom of needle notch and Hook Point (C) should be approx 0.05mm (See Fig.20)

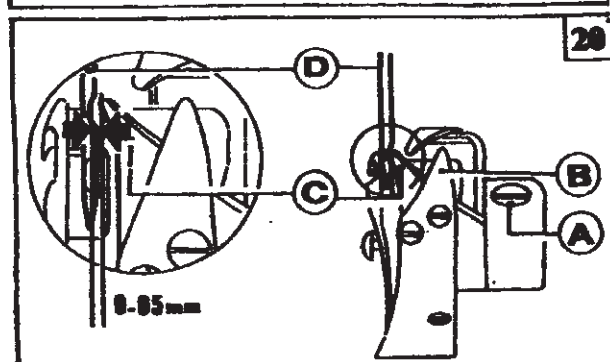
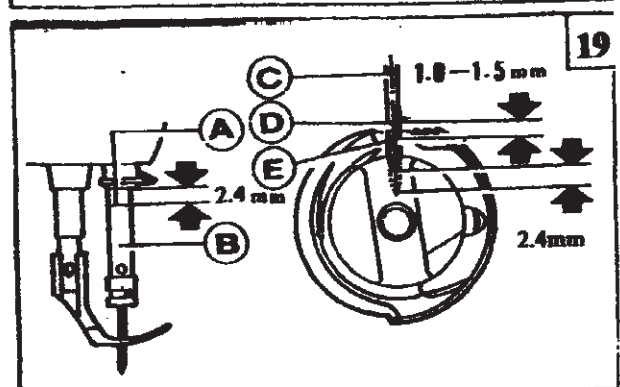

17. REPLACE ROTATING HOOK (Fig.21)

1) Lift needle bar to the highest position of its stroke. 2) Remove throat plate, take down needle and bobbin case.

3) Loosen Screw (C) of hook positioner and take down Hook Positioner (A).

4) Loosen two Screws (D) of rotating hook.

5) Turn balance wheel to raise feed bar to its highest position, then take down the rotating hook by turning it away from feed bar.

6) Installing the hook can be done in reverse sequence. Note that Needle (B) and the convex surface of Hook Positioner (A) should align with a clearance of 0.5-0.7mm between them.

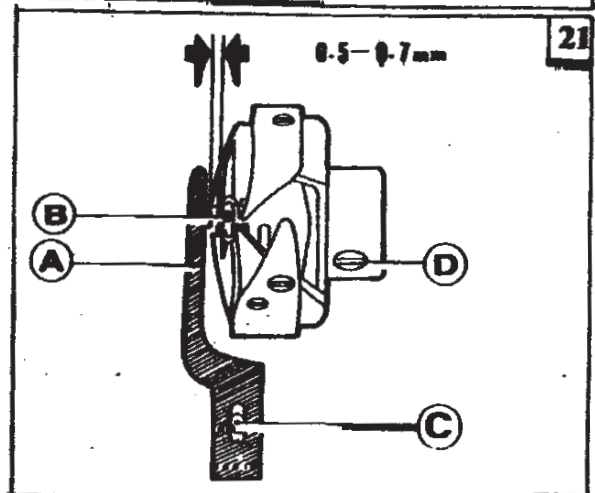

18. ADJUST THE HEIGHT OF FEED DOG (Fig. 22,23)

1) Turn balance wheel until feed dog is lifted to its highest position from throat plate surface.

2) Loosen Screw (A) of feed lifting rock shaft crank right (See Fig. 22, b)

3) Move Feed Bar (B) in the direction shown by the arrow in Fig. 22 (a) to adjust the height of the feed dog. The standard height of feed dog is that the top of feed dog is 1.0mm above Throat Plate Surface (B).

4) After the adjustment, be sure to tighten Screw (A).

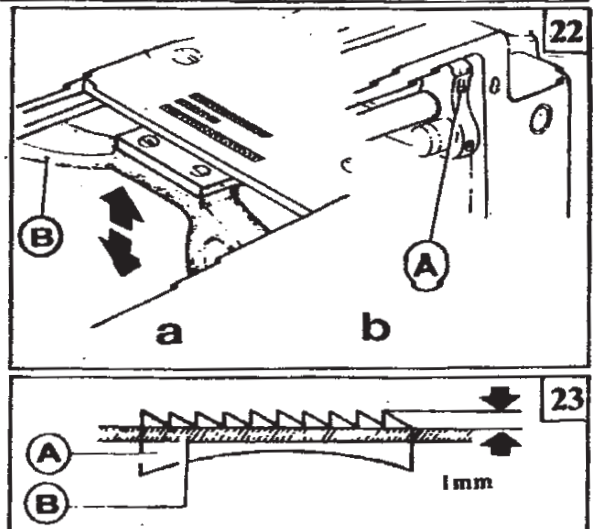

19. ADJUST THE POSITION OF FEED DOG (Fig.24, 25)

The standard position of feed dog is that the clearance between the front end of the throat plate slot and the first tooth of the fully advanced feed dog is 1mm, as shown in Fig. 24.

1) Fully advance the feed dog toward the front end of the throat plate slot.

2) Loosen Feed Rock Shaft Crank Screw (A), See Fig. 25 (b).

3) Move Feed Bar (B) in the direction shown by the arrow in Fig. 25 (a) to adjust the feed dog position.

4) After the adjustment, be sure to tighten Screw (A).

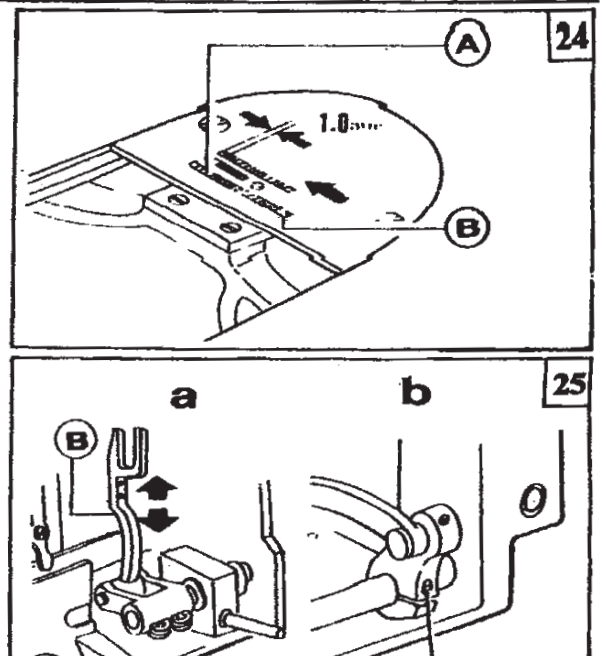

20. TIME FEED MOTION TO NEEDLE MOTION (Fig.26, 27, 28)

The standard timing of feed motion to needle motion is that the top of Feed Dog (C) is flush with Throat Plate Surface (B) when the point of Needle (A) reaches Throat Plate Surface (B). See Fig.26

If feed motion is not timed to needle motion, adjust as follows (See Figs. 27 and 28)

1) Remove Arm Side Cover (F).
2) Loosen Set Screws (A) and (D) of feed and feed lifting eccentric.

3) Hold Feed and Feed Lifting Eccentric (B) and turn Balance Wheel (E) slowly until the upper edge of Arm Shaft Oil Hole (C) aligns with the lower edge of Reference Hole (G) of feed and feed lifting eccentric.

4) Leave a clearance of 0.3-0.5mm between Feed and Feed Lifting Eccentric (B) and Eccentric Sleeve (H), then tighten Set Screws (A) and (D).

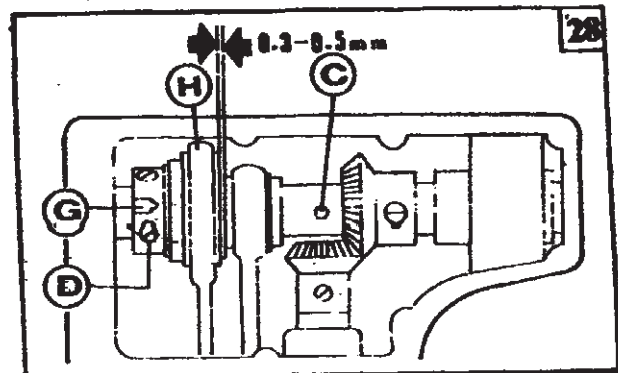
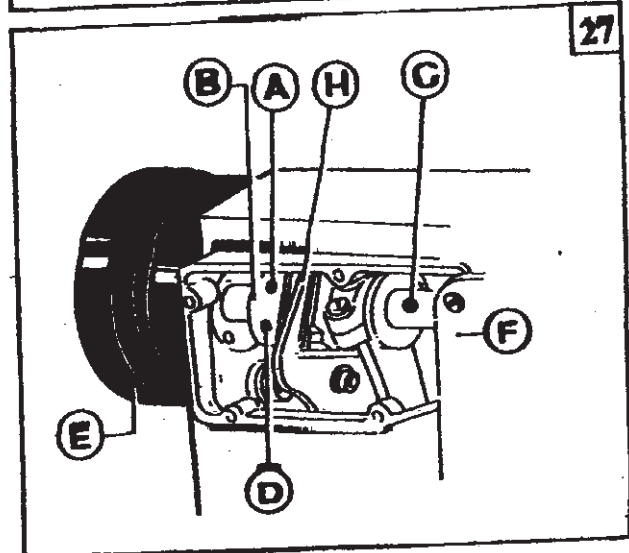
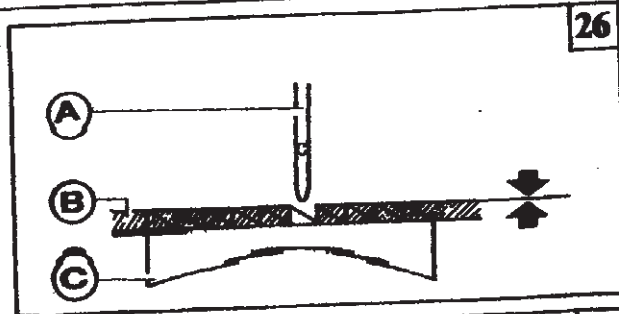

21. ADJUST OPENING TIME OF THE TENSION DISCS (Fig. 29)

Within the presser foot lift range of 2-7mm opening time of the tension discs can be adjusted as follows:

1) Remove the rubber plug from the back of arm and loosen Screw (A) of knee lifter lever (left).

2) Move the tension releasing cam leftward for earlier opening or rightward for later opening. It will facilitate the adjustment to put under the presser foot a block as thick as the presser foot lift.

3) After the adjustment, fully tighten Screw (A).

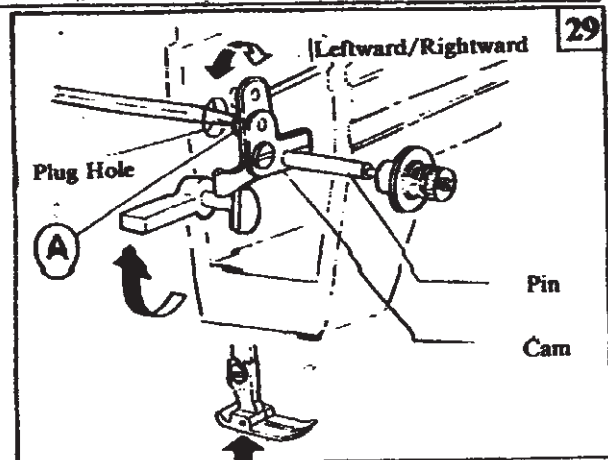

Adjusting the lubrication of rotating hook

The lubrication of the rotating hook can be adjusted by Oil Adjusting Screw (A) as follows:

1) Turn Oil Adjusting Screw (A) clockwise to increase oil and turn Oil Adjusting Screw (A) counterclockwise to decrease oil.

2) Oil Adjusting Screw (A) adjusts oil amount within 5 turns. When Oil Adjusting Screw (A) is fully tightened, oil amount is maximum.

3) Readjustment depends on temperature, sewing speed and the like. In practice, oil amount can be judged as follows: remove the throat plate and place a piece of paper on instead, run the machine for about 20 seconds, then check the oil splashed on the paper.

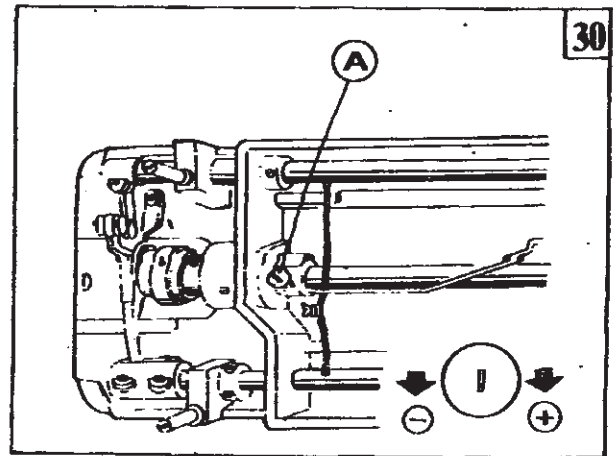

23. REGULAR CLEANING (Fig.31, 32, 33)

1) Cleaning feed dog (See Fig.31)

Remove the throat plate and clear off the dust and lint between feed dog tooth slots.

2) Cleaning rotating hook (See Fig.32)

Swing out the machine head and clean the hook. Wipe the bobbin case with soft cloth.

3) Cleaning oil pump screen (See Fig.33)

Swing out the machine head and clear off the dust and dirt on the oil pump screen.

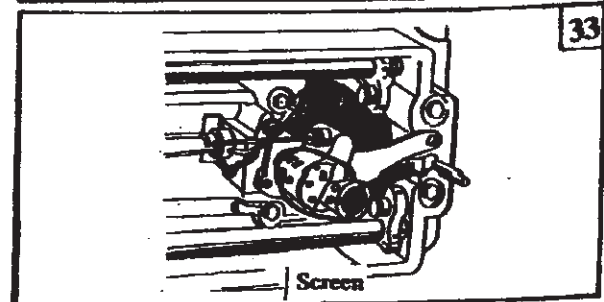
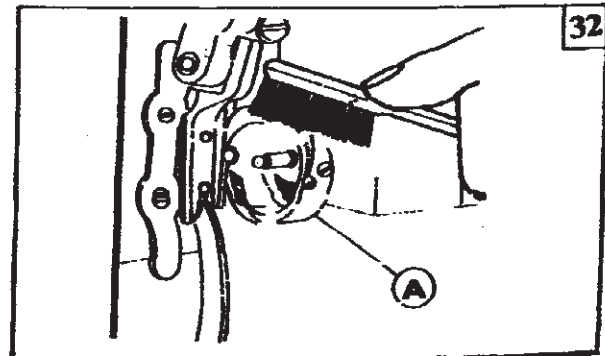
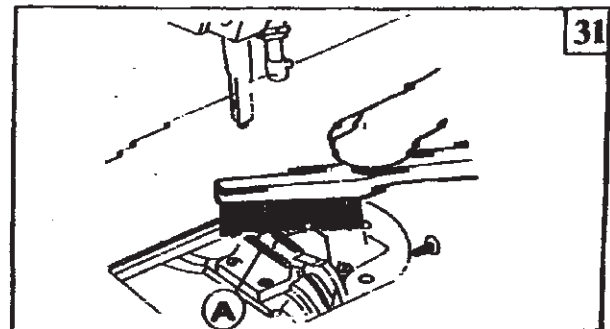

1

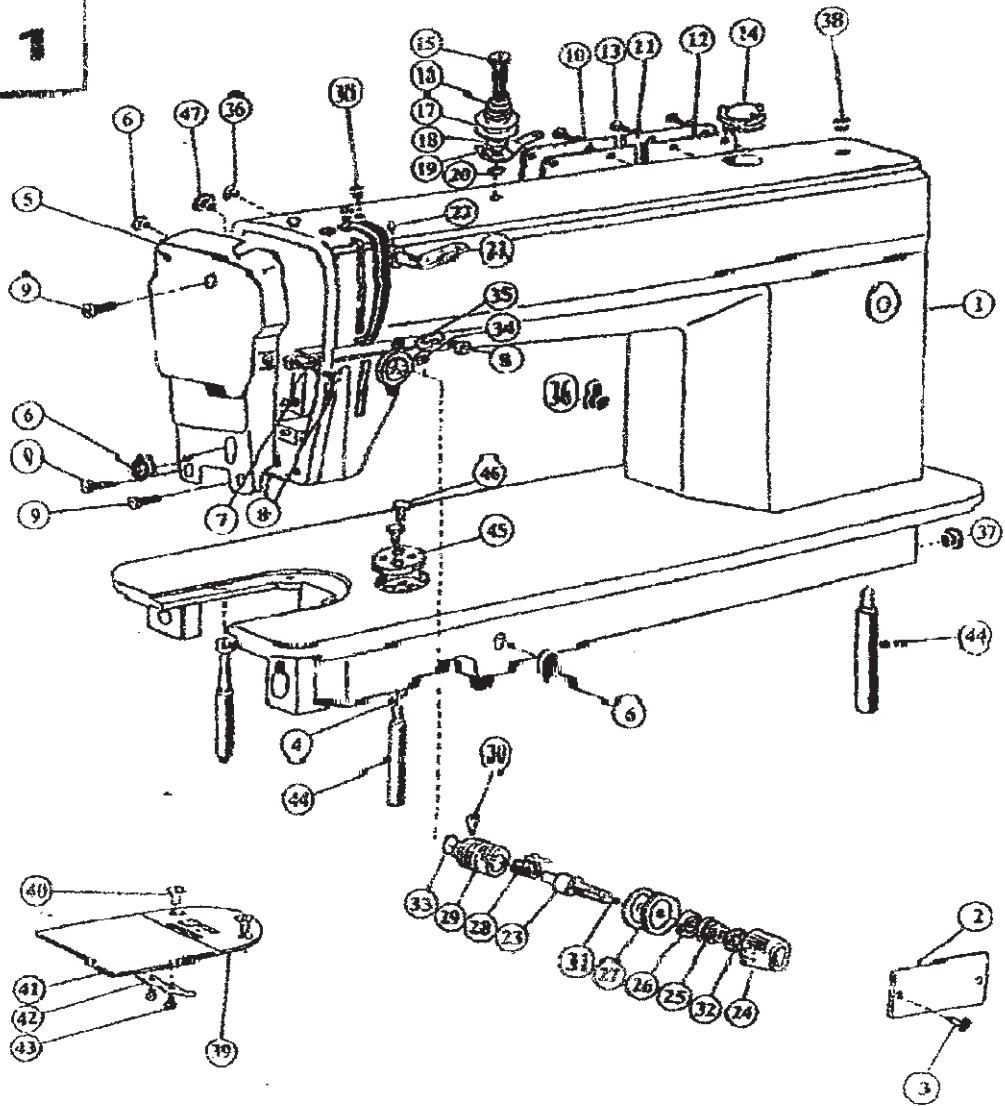

1. Casting and Accessories

No.	Ref No.	Description	Pcs.	Remarks
1	21H1-001A2	Arm	1	
2	21H1-003A	Trade mark plate	1	
3	GB827-86	Trade mark plate rivet	4	2.5 x 5
4	GB93-76	Spring washer	2	6
5	21H1-005	Face plate	1	
6	72T1-004C4	Rubber plug(φ 11.8)	1	
6	72T1-004C4	Rubber plug(φ 11.8)	1	
6	72T1-004C4	Rubber plug(φ 11.8)	1	
7	74T1-004C1	Thread guide on face plate	1	
8	22T1-003C6	Set screw	1	SM9/64"(3.57) x 40/6
9	20H1-003	Set screw	3	SM11/64"(4.37) x 40/10
10	21H1-007	Arm side cover(left)	1	
11	21H1-008	Arm side cover(right)	1	
12	21H1-009	Gasket for arm side cover	1	
13	72T1-017	Set screw	8	SM11/64"(4.37) x 40/9
14	12H1-007C1	Oil check window	1	
15	22T1-009E1	Screw type tension stud	1	
16	22T1-009E2	Spring for pre-tension	1	
17	22T1-009E3	Disc for pre-tension	2	
18	22T1-009E4	Space for pre-tension	1	
19	22T1-009E5	Pre-tension thread guide	1	
20	GB895-76	Stop ring	1	
21	22T1-010	Three-hole thread guide	1	
22	22T1-011	Set screw	1	SM11/64"(4.37) x 40/5
23	22T1-012F1	Thread tension stud	1	
24	72T1-007F1	Thumb nut	1	
25	22T1-012F3	Thread tension spring	1	
26	72T1-007F2	Thread tension releasing disc	1	
27	72T1-007F5	Thread tension disc	2	
28	22T1-012F6	Thread take-up spring	1	
29	22T1-007F3	Thread tension regulating bar	1	
30	22T1-012F8	Set screw	1	SM9/64"(3.57) x 40/6
31	22T1-012F9	Thread tension releasing pin	1	
32	22T1-012F10	Stop disc	1	
33	22T1-012F11	Rubber ring	1	
34	72T1-008	Set screw	1	SM15/64"(5.95) x 28/6
35	74T1-005	Thread guide at arm center	1	
36	72T1-009	Rubber plug(φ 8.8)	2	
37	72T1-010	Rubber plug(φ 27)	1	
38	72T1-011	Rubber plug(φ 5.7)	2	
39	11H1-016	Needle plate	1	
40	72T1-019	Needle plate screw	2	SM"/64"(4.37) x 40/4.5
41	22T1-021G1	Slide plate	1	
42	22T1-021G2	Slide plate spring	1	
43	22T1-021G3	Set screw	2	SM3/32"(2.38) x 56/2.2
44	22T1-022	Leg	3	
45	72T1-014	Cloth guide plate	1	
46	72T1-013	Set screw	2	SM11/64"(4.37) x 40/5
47	72T1-004C1	Rubber plug	1	

2.

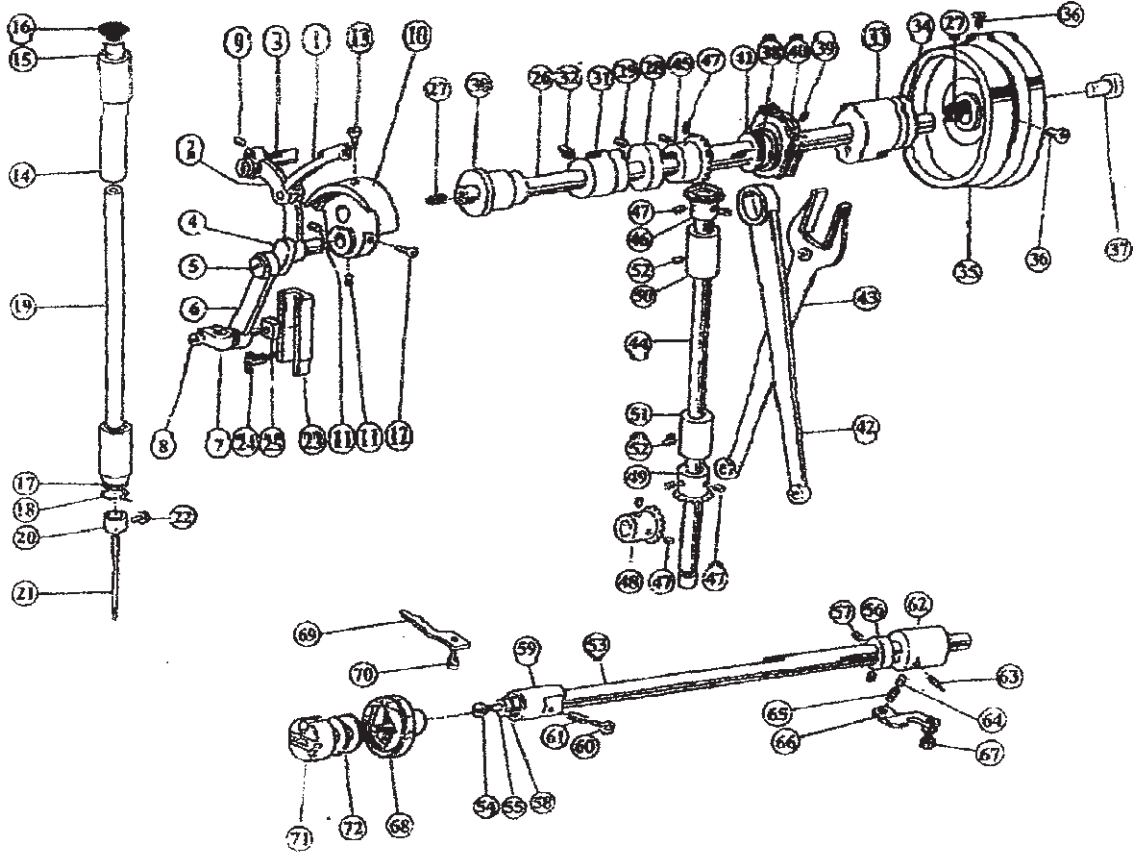

2. Internal Mechanisms

No.	Ref. No.	Description	Pcs.	Remarks
1	11H2-001A1a1	Thread take-up lever	1	
2	11H2-001A1b1	Thread take-up lever link	1	
3	22T2-001A3	Hinge pin	1	
4	73T2-001A1	Thread take-up crank	1	
4	22T2-001A5	Needle bearing	2	
5	22T2-001A6	Set screw(left handed)	1	
6	72T2-001A3	Needle bar link	1	
7	22T2-001A8	Needle bar adaptor	2	
8	22T1-001A9	Set screw	1	SM9/64*(3.57) x 40/6
9	22T2-002	Set screw	1	SM15/64*(5.95) x 28/10
10	72T2-004B1	Needle bar crank	1	
11	72T2-004B2	Set screw	2	SM1/4*(6.35) x 40/6
12	22T2-006	Set screw	1	SM9/32*(7.14) x 28/13
13	22T2-007	Set screw	1	SM9/32*(7.14) x 28/14
14	22T2-008	Needle bar bushing(upper)	1	
15	22T2-010	Felt plug	1	
16	72T2-005	Rubber plug	1	φ 8.8
17	73T2-005	Needle bar bushing(lower)	1	
18	73T2-006	Lower thread guide	1	
19	74T2-004	Needle bar	1	
20	73T2-003	Thread guide for needle b	1	
21	73T2-004	Needle	1	DB x 1-2 #22
22	22T2-017	Needle clamp screw	1	SM1/8*(3.18) x 44/4.5
23	22T2-018	Guide for slide block	1	
24	22T2-019	Set screw	2	SM11/64*(4.37) x 40/8
25	22T2-020	Slide block	1	

No.	Ref. No.	Description	Pcs.	Remarks
26	72T3-001A1	Arm shaft	1	
27	22T3-001A2	Rubber plug(ϕ 7.4 x 10)	2	
28	22T6-005B1	Collar for arm shaft	1	
29	22T3-002B2	Set screw	2	SM1/4"(6.35) x 40/4
30	22T3-003	Arm shaft bushing left	1	
31	22T3-004	Arm shaft bushing middle	1	
32	22T2-002	Set screw	1	SM15/64"(5.95) x 28/10
33	22T3-005	Arm shaft bushing right	1	
34	22T3-006F	Oil seal	1	
35	20H2-004	Balance wheel	1	
36	22T3-007C2	Set screw	2	
37	22T3-008	Set screw	1	SM11/32"(8.73) x 28/10
38	11H3-002B1a1	Feed lifting eccentric	1	
39	72T3-005D1a3	Set screw	2	SM15/54"(5.95) x 28/7
40	72T3-005D1a2	Eccentric sleeve	1	
41	22T3-009D1b	Retaining ring	1	
42	22T3-009D1c	Crank rod for feed lifting	1	
43	73T3-001A1	Feed forked connection	1	
44	11H3-003	Vertical shaft	1	
45	22T3-010E2a1-2	Bevel gear for arm shaft	1	Z=27
46	22T3-010E2a2-2	Bevel gear for vert shaft	1	Z=18
47	22T2-005B3	Set screw	8	SM1/4"(6.35) x 40/7
48	22T3-010E2b1-2	Hook shaft gear	1	Z=21
49	22T3-010E2b2-2	Lower vertical shaft gear	1	Z=28
50	22T3-011	Upper vertical shaft bushing	1	
51	74T3-001	Lower vertical shaft bushing	1	
52	22T2-002	Set screw	2	SM15/64"(5.95) x 28/10
53	74T4-001A1	Rotating hook shaft	1	
54	22T4-001A1a1	Filter screw	1	
55	22T4-001A1a2	Filter	1	
56	72T4-002B1	Collar for hook shaft	1	GC6-1
57	72T4-002B2	Set screw	2	SM15/64"(5.95) x 28/4.
58	22T4-003G	Hook shaft oil seal "O" ring	1	
59	22T4-004	Hook shaft bushing(left)	1	
60	72T4-003	Oil adjusting screw	1	
61	22T4-006	Spring for oil adjuster	1	
62	72T4-008C	Hook shaft bushing(right)	1	
63	22T4-007C2	Oil pipe for hook shaft bus	1	
64	72T4-010	Plunger	1	
65	72T4-011	Plunger spring	1	
66	74T4-002	Guide plate	1	
67	22T5-001A4	Screw	1	SM15/64"(5.95) x 28/10
68	21H4-001A	Rotating hook complete	1	
69	74T4-004	Rotating hook positioner	1	
70	22T4-015	Set screw	1	SM11/64"(4.37) x 40/10
71	74T4-005C	Bobbin case	1	
72	11H4-001	Bobbin	1	

3.

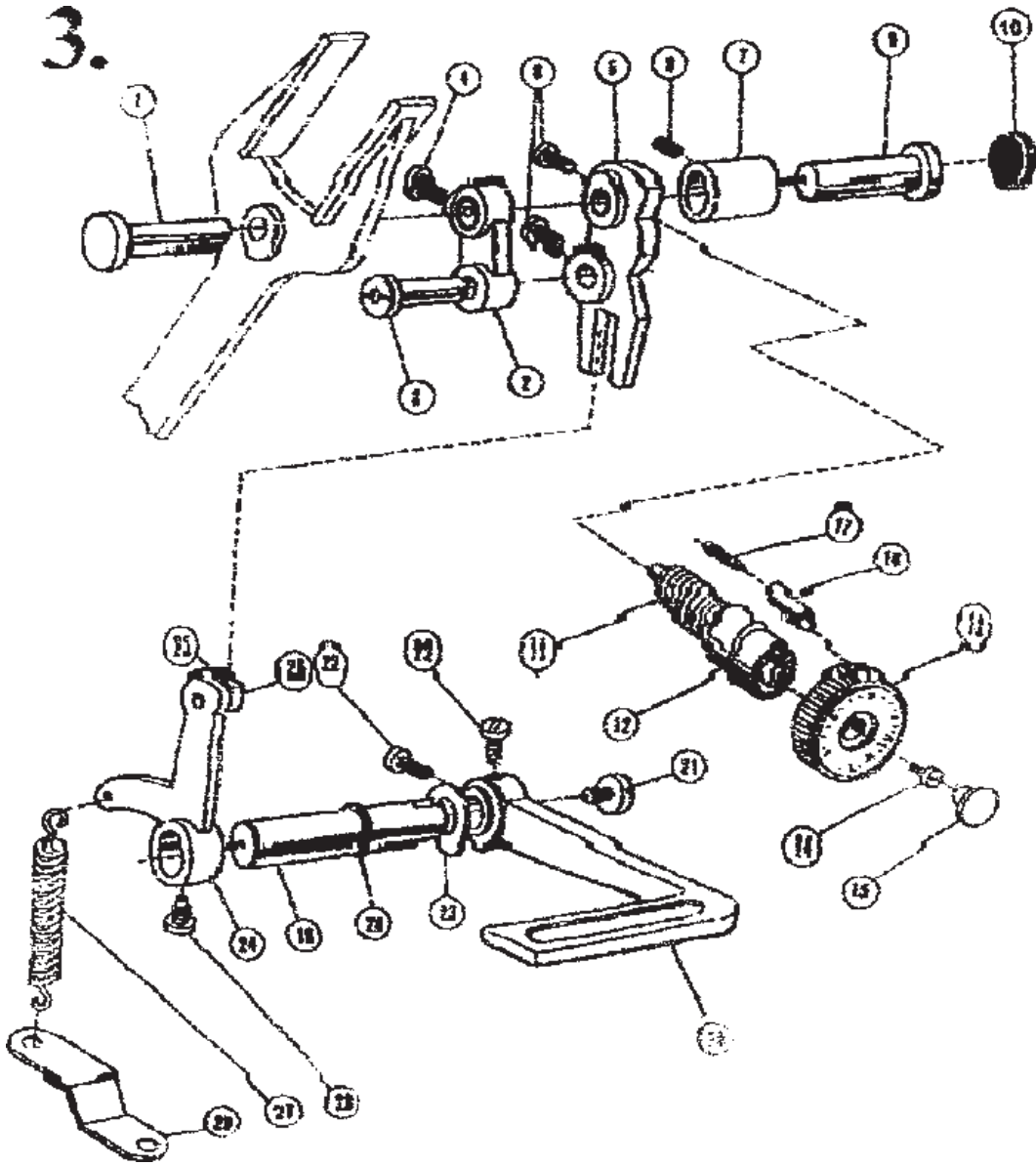

3. STITCH LENGTH REGULATING MECHANISM

No.	Ref. No.	Description	Pcs.	Remarks
1	22T5-001A1	Hinge pin	1	
2	22T5-001A2	Feed connecting link	1	
3	22T5-001A3	Hinge pin for feed connecting li	1	
4	22T5-001A4	Set screw	1	SM15/64*(5.95) x 28/10
5	73T5-002B1	Feed regulator	1	
6	22T5-001A4	Set screw	2	SM15/64*(5.95) x 28/10
7	72T5-002	Feed regulator bushing	1	
8	22T2-002	Set screw	1	SM15/64*(5.95) x 28/10
9	22T5-004	Hinge pin for feed regulator	1	
10	72T5-003	Rubber plug(ϕ 20 x 4)	1	
11	73T5-003C1	Feed regulator screw bar	1	
12	22T5-006C4	O-ring	2	ϕ 14 x 2.4
13	11H5-001A1	Dial	1	
14	22T5-006C3	Screw	1	SM3/16*(4.76) x 28/8
15	72T5-005	Rubber plug	1	
16	22T5-008	Stopper pin	1	
17	22T5-009	Spring for stopper pin	1	
18	72T5-006C1	Reverse feed lever	1	
19	22T5-010D2a	Reverse feed lever shaft	1	
20	22T5-010D2b	O-ring	1	ϕ 9 x 1.9
21	22T5-010D3	Screw	1	SM3/16*(4.76) x 28/6.5
22	22T5-001A4	Screw	2	SM15/64*(5.95) x 28/10
23	22T5-011	Washer	1	
24	22T5-012E1	Reverse feed crank	1	
25	22T5-012E1a1	Slide block pin	1	
26	22T5-012E1a2	Slide block	1	
27	22T5-012E2	Spring for reverse feed crank	1	
28	22T5-013	Screw	1	SM15/64*(5.95) x 28/14
29	22T5-014	Bracket for spring	1	

4.

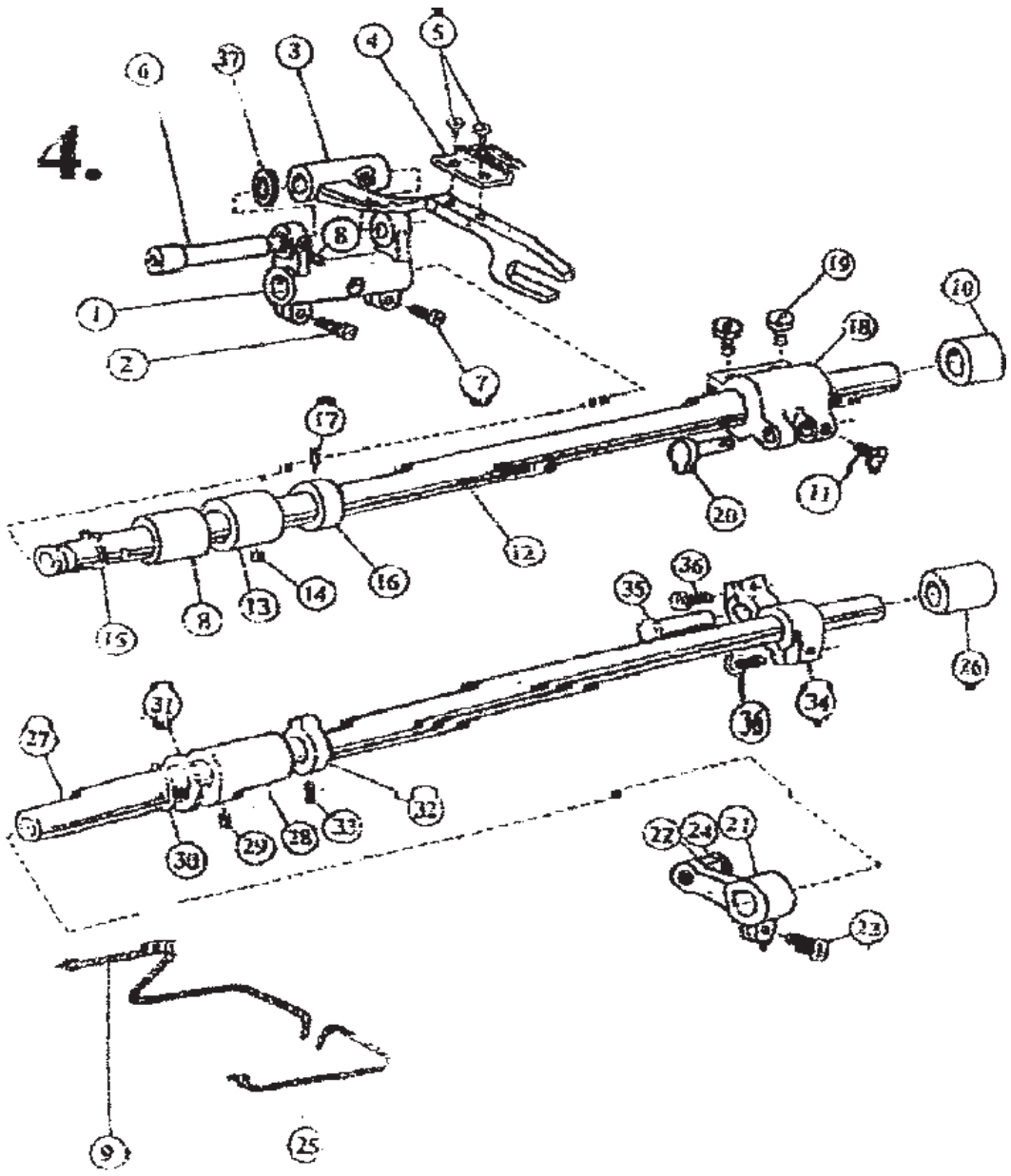

4. FEEDING AND FEED LIFTING MECHANISM

No.	Ref. No.	Description	Pcs.	Remarks
1	22T6-001A1a	Feed rock shaft crank	1	
2	72T6-001A6	Screw	2	SM3/16"(4.76) x 28/15
3	20H11-001B1	Feed bar	1	
4	22T6-001A3	Feed dog	1	
5	22T6-001A4	Screw	2	SM1/8"(3.18) x 44/6
6	11H6-004	Shaft for feed bar	1	
7	22T2-019	Screw	1	SM1 1/64"(4.37) x 40/8
8	11H6-007	Bushing for feed rock shaft(left)	1	
9	72T6-001A5	Oil braid	1	φ 2.5 x 315
10	11H6-006	Bushing for feed rock shaft(right)	1	
11	22T5-001A6	Screw	1	SM15/64"(5.95) x 28/10
12	11H6-001	Feed rock shaft	1	
13	11H6-008	Bushing for feed rock shaft	1	
14	72T4-002B2	Screw	1	SM15/64"(5.95) x 28/4
15	GB894-76	C-type stop ring	1	15
16	22T6-005B1	Collar	1	
17	22T3-002B2	Screw	2	SM1/4"(6.35) x 40/4
18	21H6-001	Feed rock shaft crank	1	
19	22T6-001A1b	Screw	2	SM3/16"(4.76) x 28/12
20	21H6-002	Hinge pin	1	
21	72T6-002B1a	Feed lifting rock shaft crank(left)	1	
22	72T6-002B1b	Hinge pin	1	
23	22T6-008D3	Screw	1	SM11/64"(4.37) x 40/12
24	72T6-007D1a	Feed lifting connection sleeve	1	
25	72T6-002B4	Oil braid	1	φ 2.5 x 265
26	11H6-010	Bushing for feed lifting rock shaft	1	
27	54T6-002	Feed rock lifting shaft	1	
28	22T6-012	Bushing for feed lifting rock shaft	1	
29	22T2-002	Screw	1	SM15/64"(5.95) x 28/10
30	GB894-76	C-type stop ring	1	15
31	22T6-013	Washer	1	
32	22T6-005B1	Collar for feed lifting rock shaft	1	
33	22T3-002B2	Screw	2	SM1/4"(6.35) x 40/4
34	72T6-003C1	Feed lifting rock shaft crank(right)	1	
35	22T6-007	Hinge pin	1	
35	22T2-009	Screw	1	
36	22T6-001A1b	Screw	2	SM3/16"(4.76) x 28/12
37	22T6-001A6	Washer	1	

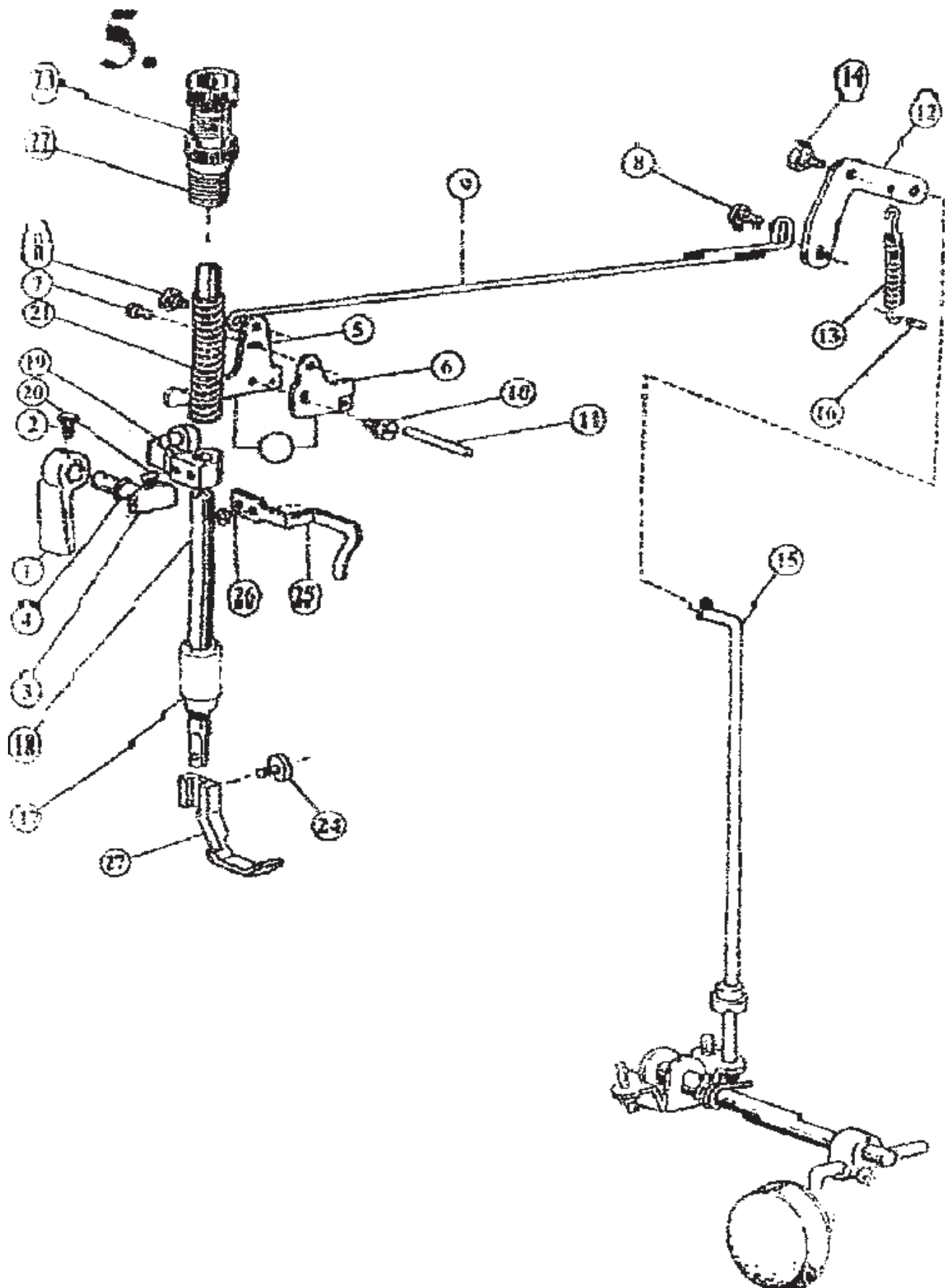

3. PRESSER FOOT MECHANISM

No.	Ref. No.	Description	Pcs.	Remarks
1	21H7-001A1	Presser bar lifter	1	
2	72T1-017	Set screw	1	SM11/64"(4.37) x 40/5
3	21H7-001B1	Presser bar lifting cam	1	
4	72T7-008	Oil seal for press bar lifting cam	1	φ 8 x 1.9
5	22T7-004B1a	Knee lifter lever(left)	1	
6	72T7-002B1-1	Tension releasing cam	1	
7	22T7-004B1c	Screw	1	SM11/64"(4.37) x 40/6
8	22T7-004B2	Hinged screw	2	SM3/16"(4.76) x 28/3.5
9	22T7-004B3	Knee lifter rod	1	
10	22T7-005	Bolt	1	SM15/64"(5.95) x 28/13
11	22T7-006	Tension releasing pin	1	
12	22T7-007C1	Knee lifter lever(right)	1	
13	22T7-007C2	Spring	1	
14	22T7-005	Bolt for knee lifter lever	1	SM15/64"(5.95) x 28/10
15	72T7-003C1	Knee lifter connecting rod	1	
16	22T7-008	Pin for spring	1	
17	72T7-009	Presser bar bushing	1	
18	20H8-001	Presser bar	1	
19	21H7-002C1	Presser bar lifting bracket	1	
20	72T3-005D1a3	Set screw	1	SM15/64"(5.95) x 28/7
21	21H7-003	Presser bar spring	1	
22	20H8-002A	Pressure regulating thumb screw	1	
23	22T7-014E2	Lock nut	1	
24	22T7-015	Set screw	1	SM9/64"(3.57) x 40/11
25	72T7-012	Upper thread guide	1	
26	82T5-010	Screw	1	SM11/64"(4.37) x 40/7
27	20H8-004	inner presser	1	

6.

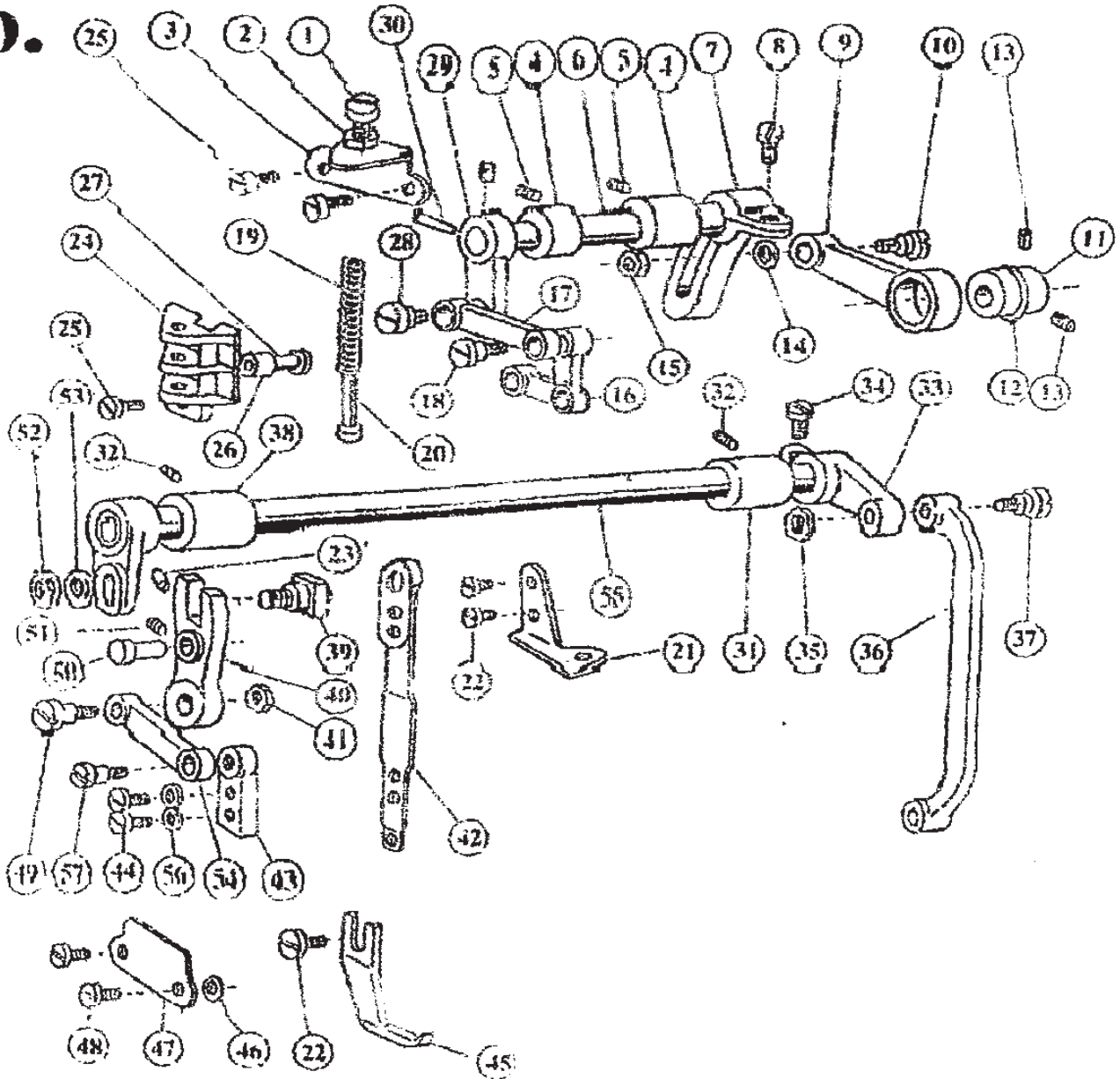

6.PRESSER LIFTING, FEEDING MECHANISM

No.	Ref. No.	Description	Pcs	Remarks
1	20H9-007A	lifting presser adjusting screw	1	
2	20H9-007B	lifting presser adjusting nut	1	
3	20H9-006	lifting presser bracket for spring	1	
4	20H1-006D	Presser lifting shaft bushing	2	
5	22T1-011	Screw	2	
6	20H9-008B	Presser lifting shaft	1	4 x 20
7	21H8-001	Adjusting crank for eccentric wheel ro	1	
8	20H13-009A2	Set screw	1	
9	21H8-001A	Eccentric wheel rod	1	
10	20H9-010	Set screw	1	
11	20H9-011A2	Eccentric wheel	1	
12	GB894-86	C-type stop ring	1	
13	72T2-004B2	Screw	2	
14	GB95-85	Washer	1	
15	GB52008	Nut	1	
16	21H8-002	Presser feed crank	1	
17	20H9-001A2	Presser feed crank link	1	
18	20H9-001A3	Screw	1	
19	20H9-005	lifting presser spring	1	
20	20H9-004B	Presser spring guide	1	
21	20H9-001A8	lifting presser guide plate	1	
22	20H8-005	Screw	1	
23	GB877-86	pin	1	
24	20H9-002	lifting presser plate	1	
25	72T2-003	Screw	2	
26	20H9-003	Lifting presser spring guide pin	1	
27	20H9-001A5	Feed crank guide shaft	1	
28	20H9-001B2	Screw	1	
29	20H9-008A	Presser lifting crank	1	
30	GB117-76	pin	1	
31	20H1-006B	Presser swing shaft bushing(right)	1	
32	22T1-011	Screw	2	
33	20H13-009A1	Presser swing crank(right)	1	
34	20H13-009A2	Screw	1	
35	20H9-007B	lifting presser adjusting nut	1	
36	21H8-003	Presser swing crank(right) rod	1	
37	20H13-009B	Screw	1	
38	20H1-006B	Presser swing shaft bushing(left)	1	
39	20H13-010A	Lifting presser sway crank shaft compl	1	
40	20H13-010E	Lifting presser sway crank	1	
41	20H13-005B	Lock nut	1	
42	20H9-001A4	Presser rod	1	
43	20H9-001B1	Presser rod guide	1	
44	20H9-001C	Screw	2	
45	21H8-004	Out presser	1	
46	20H13-004	Space for presser rod plate	2	
47	20H13-003	Lifting presser rod plate	1	
48	22T6-008D3	Screw	2	
49	20H13-005A	Screw	1	
50	20H13-010B	Lifting presser sway crank guide pin	1	
51	72T3-005D1a3	Screw	1	
52	20H13-010C	Presser crank connecting nut	1	
53	GB95-85	Washer	1	
54	20H13-010F	Presser swing crank(left)	1	
55	20H13-006B	Presser swing shaft	1	
56	22T8-005	Washer	1	
57	20H9-001B2	Screw	1	

7.

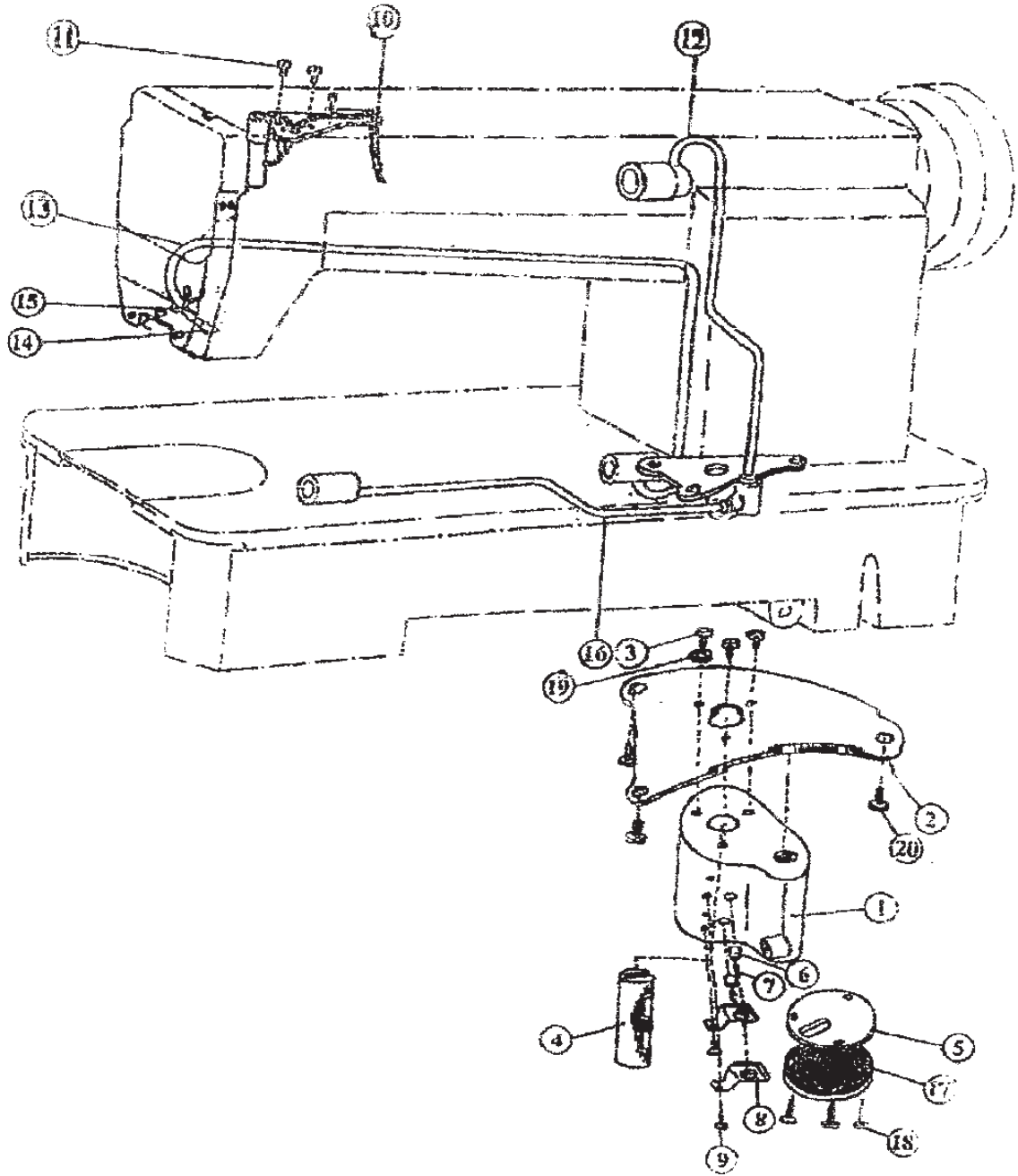

4. LUBRICATION MECHANISM

No.	Ref. No.	Description	Pcs.	Remarks
1	11H8-001	Oil pump body	1	
2	11H8-003	Oil pump body plate	1	
3	72T1-003	Screw	3	SM1 1/64" (4.37) x 40/8
4	11H8-004	Oil pump shaft	1	
5	11H8-005	Oil pump pin guide plate	1	
6	58T5-009	Plunger	2	
7	58T5-010	Plunger spring	2	
8	58T5-011	Guide plate	2	
9	22T2-017	Screw	2	SM1/8" (3.18) x 44/4.5
10	73T8-001A	Oil braid fitting plate	1	
11	22T8-012	Screw	2	SM9/64" (3.57) x 40/11
12	11H8-006A	Oil pipe for arm shaft	1	
13	72T8-002B1	Oil return pipe	1	φ 3 x 650
14	22T8-015	Felt pouch	1	
15	72T8-008	Pipe hold	1	
16	22T8-010B	Oil pipe for hook shaft	1	
17	11H8-008B	Oil pump screen complete	1	
18	11H8-010	Screw	3	SM1/8" (3.18) x 44/8
19	22T1-007	Washer	3	
20	72T2-003	Screw	3	

8.

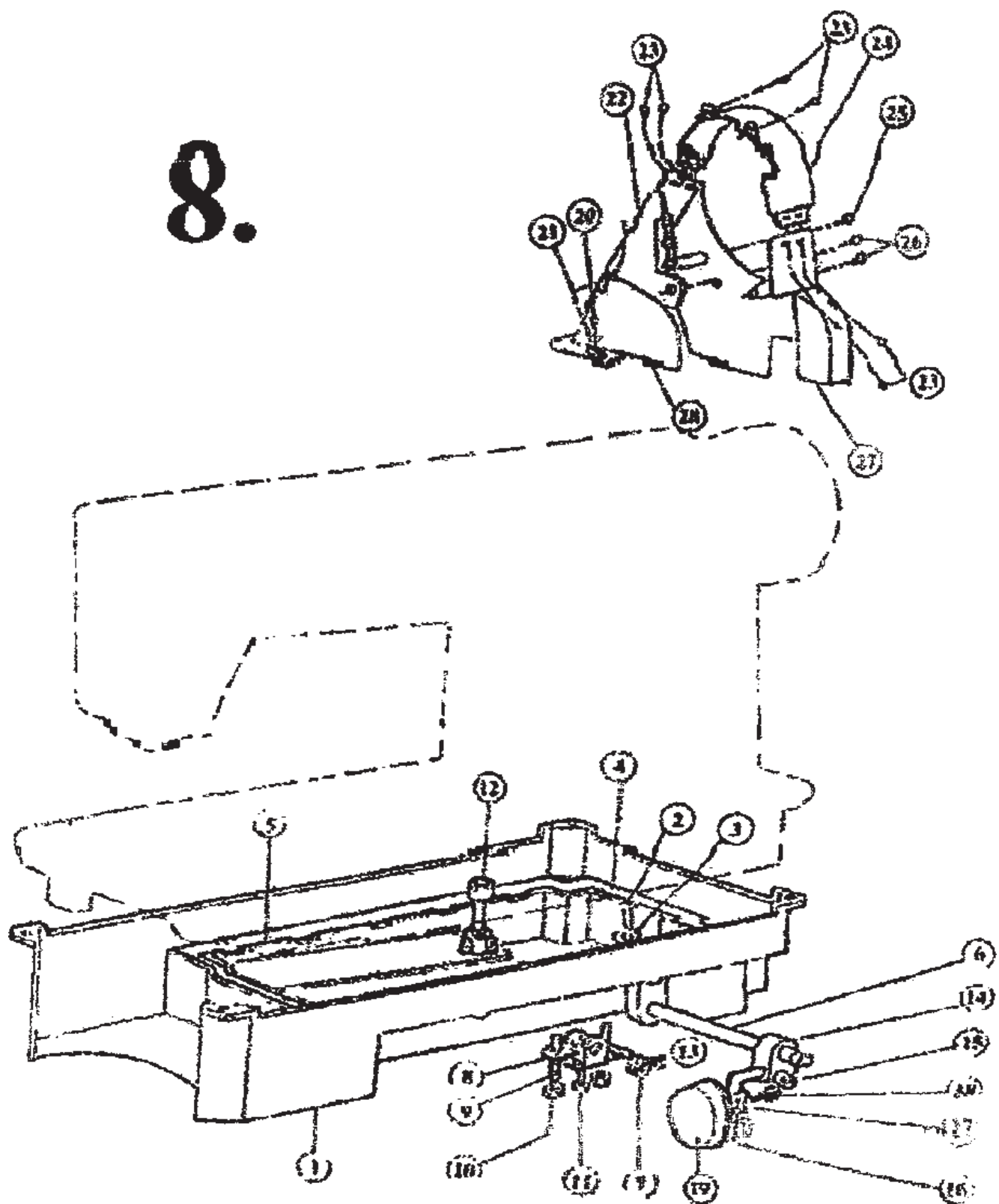

8.OIL RESERVOIR AND OTHER ACCESSORIES

No.	Ref. No.	Description	Pcs	Remarks
1	74T9-001A	Oil reservoir	1	
2	22T9-001A2	Oil drain screw	1	SM5/16"(7.94) x 28/10
3	22T9-001A3	Washer	1	
4	22T9-001A4	Gasket for oil reservoir(small)	1	
5	22T9-001A5	Gasket for oil reservoir(big)	1	
6	72T9-016	Hinge pin for knee lifter	1	
7	22T9-001A7	Backspring for knee lifter	1	
8	22T9-001A8	Knee lifter stop bracket	1	
9	22T9-001A9	Adjusting screw	2	SM15/64"(5.95) x 28/28
10	22T9-001A10	Lock nut	2	
11	22T3-007C2	Screw	1	
12	22T9-003B1	Knee lifter lifting rod	1	
13	22T9-003B2	Knee lifter bell crank	1	
14	22T9-003B3	Joint for knee lifter bell crank	1	
15	72T9-018	Set screw	2	SM5/16"(7.94) x 18/16
16	22T9-003B5	Knee lifter plate	1	
17	22T9-003B6	Bracket for knee lifter plate	1	
18	22T9-003B7	Set screw	1	SM15/64"(5.95) x 28/8
19	22T9-003B8	Pad for knee lifter plate	1	
20	GB99-76	Screw	2	φ 4.5 x 20
21	GB848-76	Washer	2	5
22	20H14-005D	Belt(upper)	1	
23	72T2-017	Screw	6	
24	20H14-005C1	Belt mark complete	1	
25	GB65-85	Screw	1	M4 x 14
26	72T9-028	Screw	2	SM15/64"(5.95) x 28/8
27	20H14-005C	Belt(lower)	1	
28	72T9-002B5	Belt complete	1	

9.

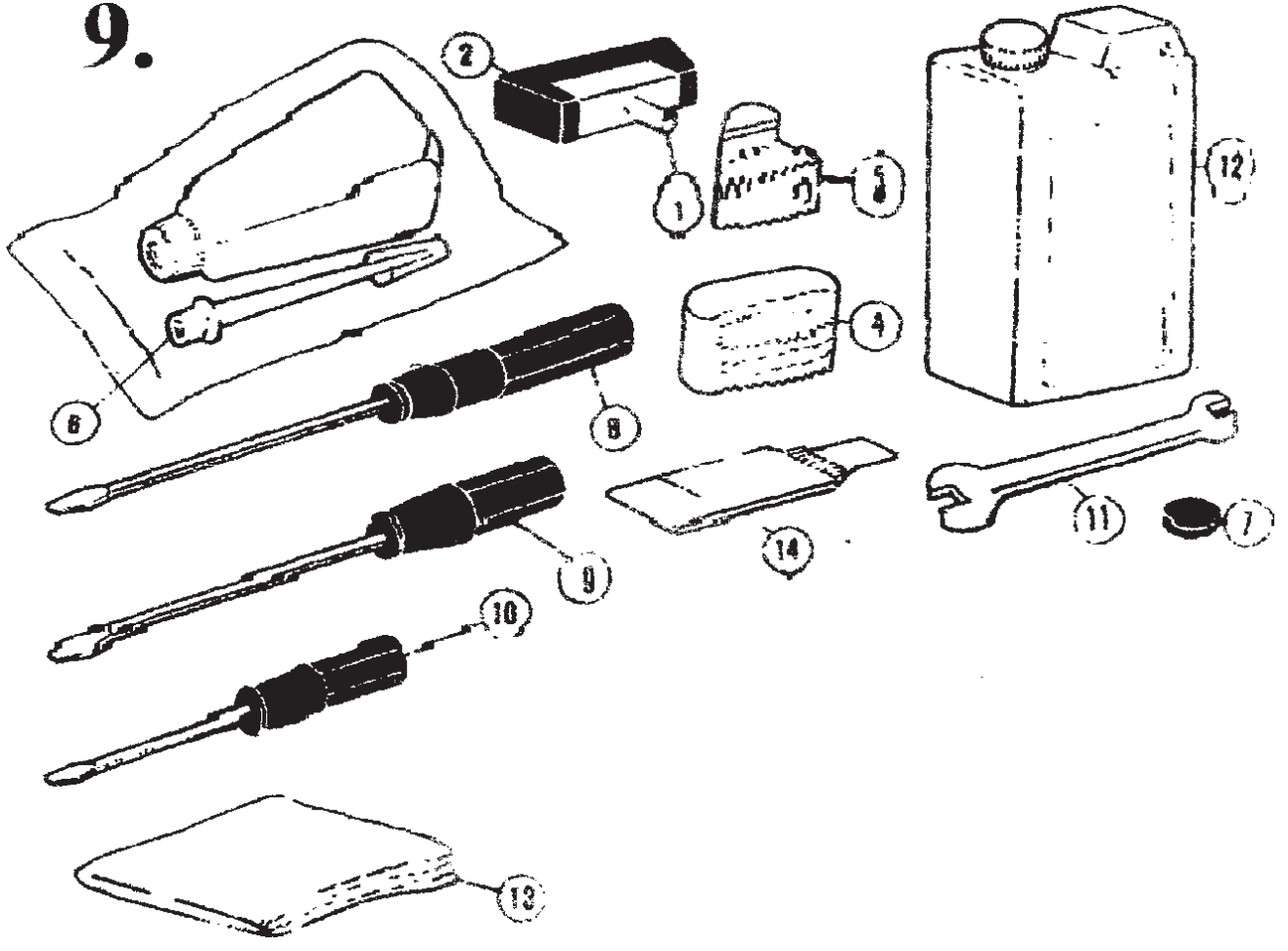

9. OTHER ACCESSORIES

No.	Ref. No.	Description	Pcs.
1	22T9-007F1	Hinge of machine head	2
2	72T9-004C1	Rubber socket for hinge	2
4	72T9-005	Rubber cushion(big)	2
5	72T9-006	Rubber cushion(small)	2
6	22T9-011	Oiler	1
7	22T9-012	Magnet	1
8	72T9-007	Screw driver(long)	1
9	72T9-020	Screw driver(media)	1
10	72T9-021	Screw driver(short)	1
11	72T9-022	Double-end wrench	1
12	22T9-017	Oil container	1
13	22T9-018	Vinyl cover	1
14	73T2-004	Needle	4

10.

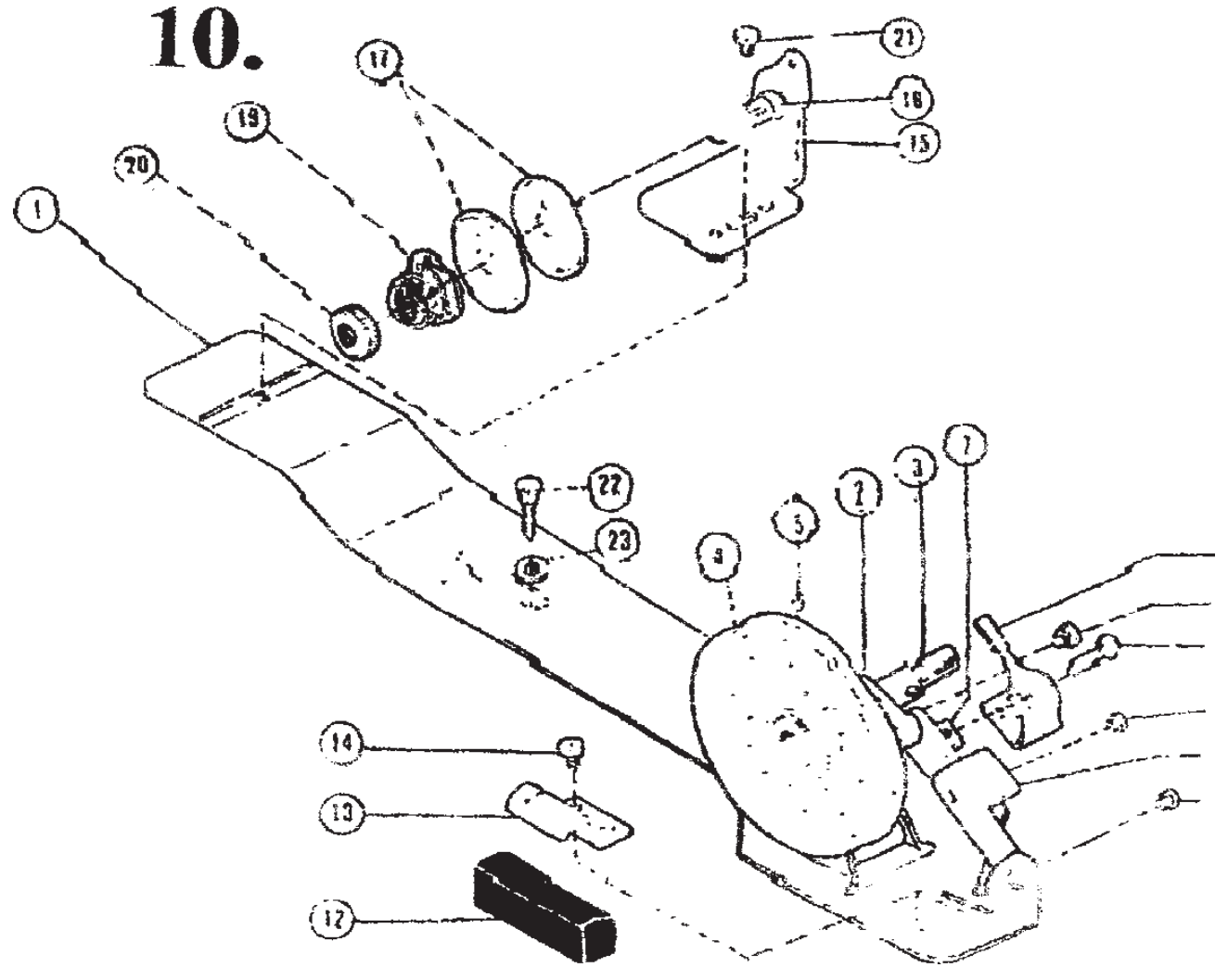

10. BOBBIN WINDER MECHANISM

No.	Ref. No.	Description	Pcs.
1	22T9-006D1	Bobbin winder base	1
2	22T9-006D2	Bobbin winder arm	1
	22T9-006D3	Shaft for bobbin winder arm	1
	22T9-006D4	Spring	1
3	7F0-022	Bobbin winder spindle	1
4	22T9-006D6	Bobbin winder pulley	1
5	22T9-006D7	Screw	1
6	22T9-006D8	Bobbin winder stop latch lev	1
7	22T9-006D9	Bobbin winder connecting ba	2
8	22T9-006D10	Rivet	1
9	22T9-006D11	Screw	1
10	22T9-006D12	Bobbin winder stop latch	1
11	22T9-006D13	Adjusting screw	1
12	22T9-006D14	Stopper block	1
13	22T9-006D15	Fixture for stopper block	1
14	22T9-006D16	Set screw	1
15	22T9-006D17	Bobbin winder tension brack	1
16	22T9-006D18	Bobbin winder tension stud	1
17	22T9-006D19	Bobbin winder tension disc	2
18	22T9-006D20	Tension stud bushing	1
19	22T9-006D21	Bobbin winder tension spring	1
20	22T9-006D22	Tension stud nut	1
21	22T9-006D23	Tension bracket screw	1
22		Wood screw	2
23		Washer	2