

CM-500

TABLE BLINDSTITCH MACHINE

INSTRUCTION MANUAL

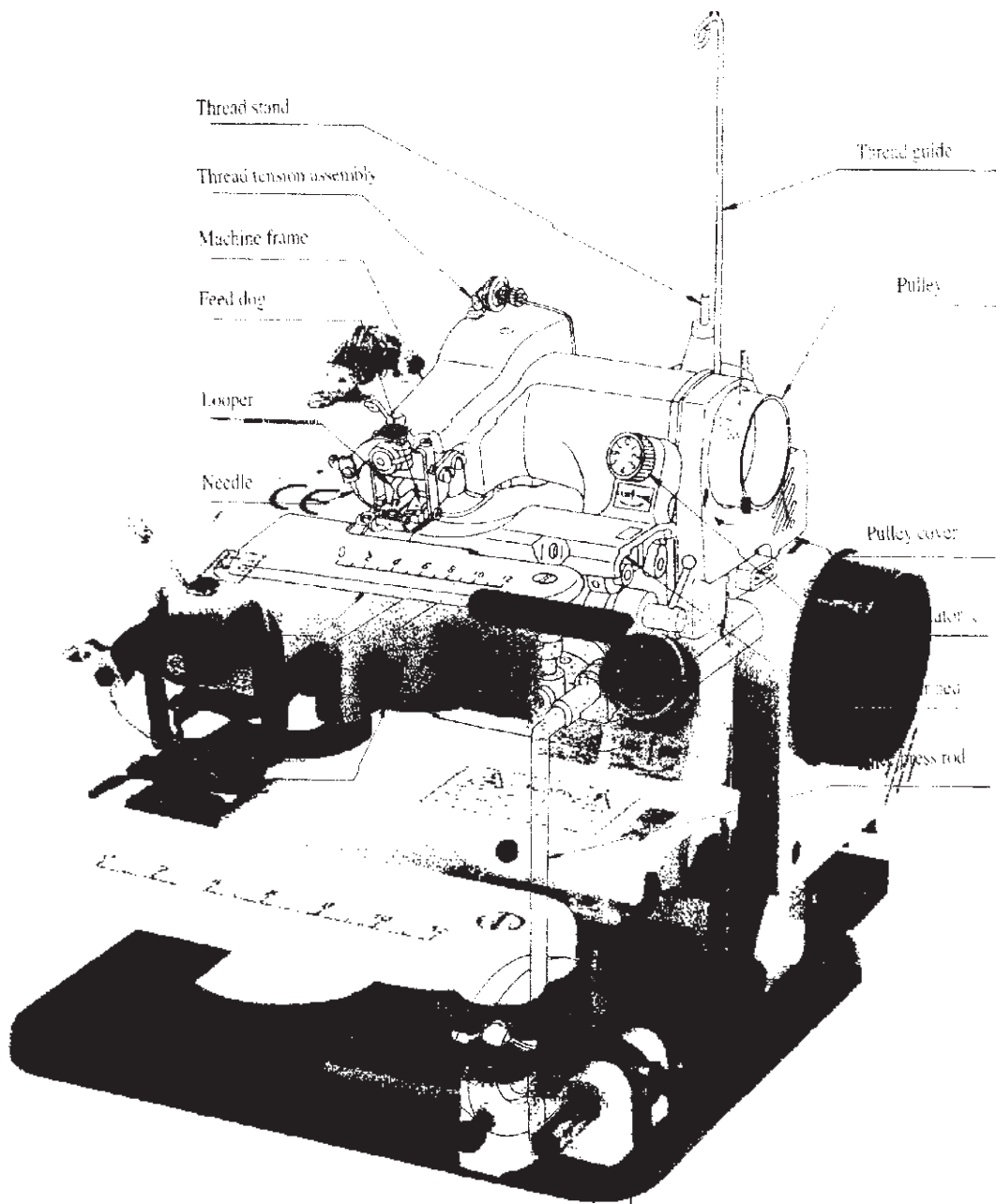

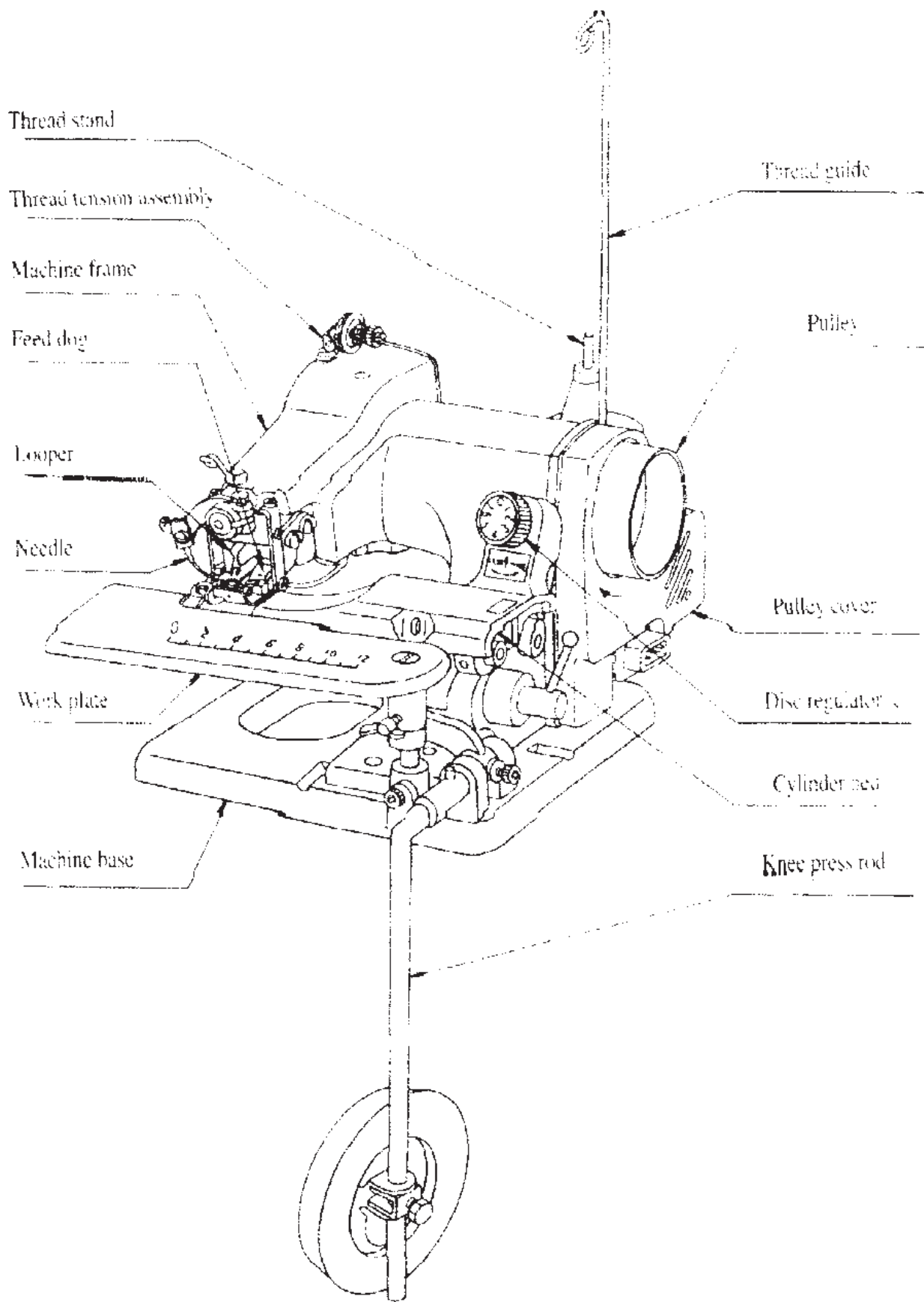

1. INSTALLING THE MACHINE

Take all spare parts and accessory out of the box

A. LOCATING THE MACHINE (FIG.1-2)

Place the machine on a steady table and close to the right forward of the table as far as possible. take the machine clamp assembly out of the spare parts to fix the bottom of the machine onto the side of the table. The machine clamp assembly can insert into the channel of the bottom through forward of right as you require. to make sure the tighten of the machine.(Please refer to the fig.1 & fig.2)

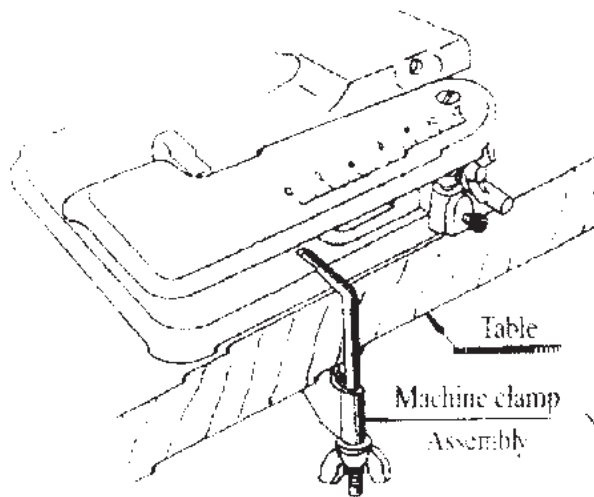

FIG.1

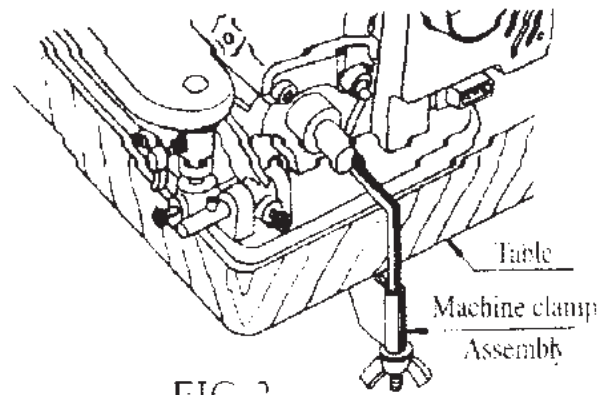

FIG.2

B. SET LINE SOCKET (FIG.3)

At first, loosen the thread guide set screw(1). Then insert the thread guide (2) and the thread guide stud (3) in the hole of the back and tighten the set screw (1).

The second, loosen the thread guide screw (4) and adjust the thread guide top (5) to face the thread stand (6). Then tighten the thread guide screw(4).

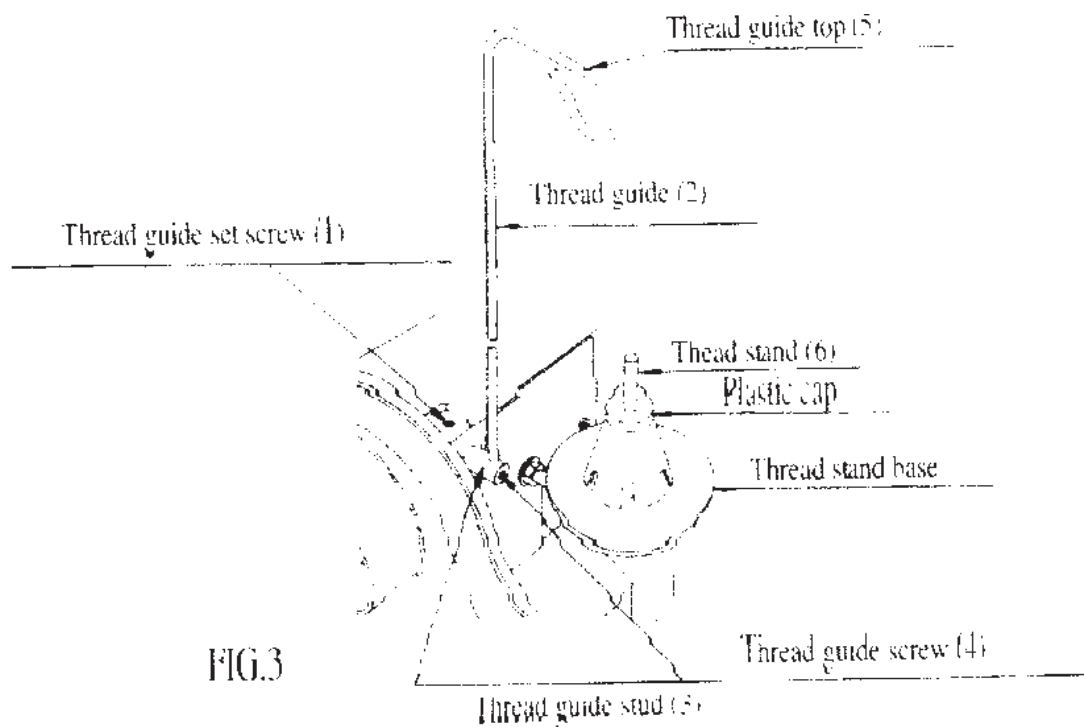

FIG.3

C. CONNECTING THE MOTOR CONTROLLER. (FIG.4-5)

Insert the three-hole connector into the joint machine and insert the standard connector in the wall-type plug, then put the motor controller on the ground to adjust the speed.

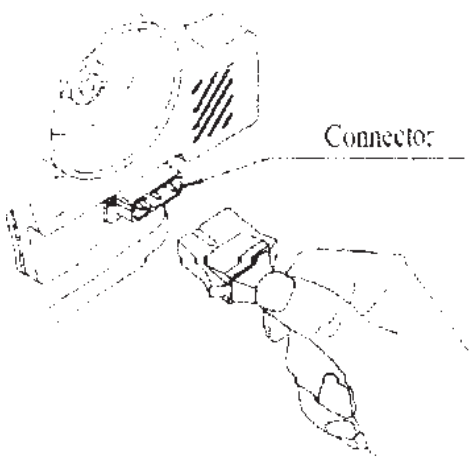

FIG.4

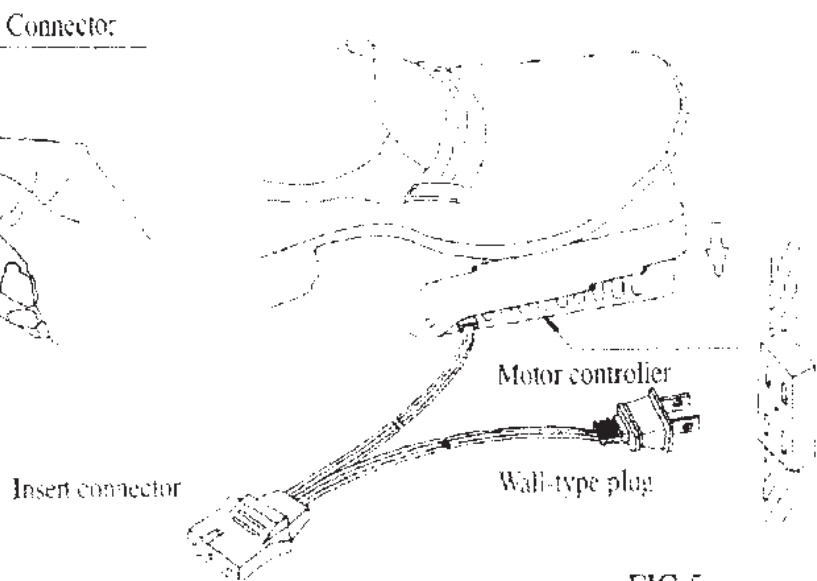
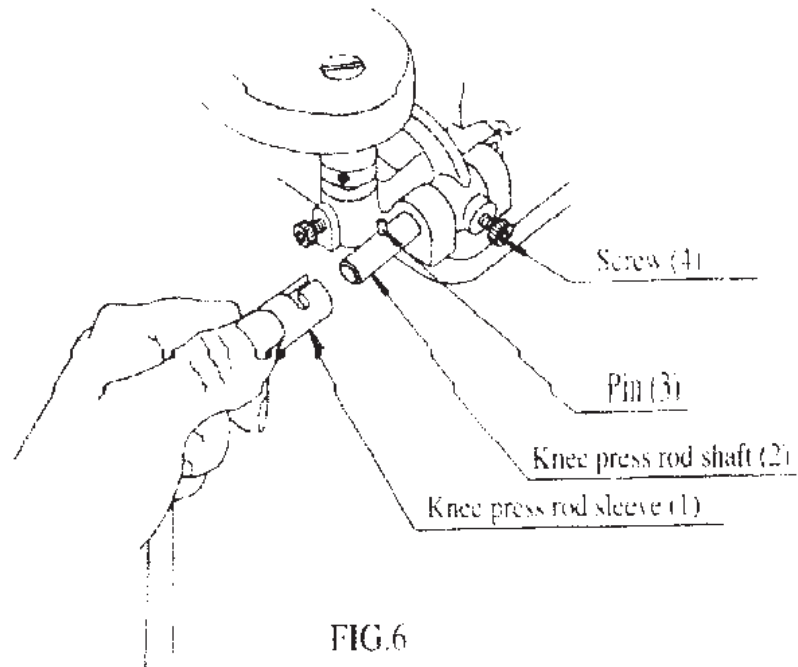

FIG.5

D. INSTALLING KNEE PRESS ROD (FIG.6)

Push the knee press rod (1) forward to the knee press rod shaft (2) and make the pin (3) be put into the I-groove smoothly. Loosen the screw (4) to adjust the angle of the knee press rod as you require and then tighten the screw (4).



2. LUBRICATION (FIG.7)

After installing the machine, pour some lubrication oil into the holes on the machine to operate smoothly and lengthen the serve life (Fig.7). You can also pour some machine oil on the running parts inside the machine to operate smoothly after opening the arm side cover and the arm rear cover. You had better pour one or two drops of machine oil before operation everyday to lengthen the serve life.

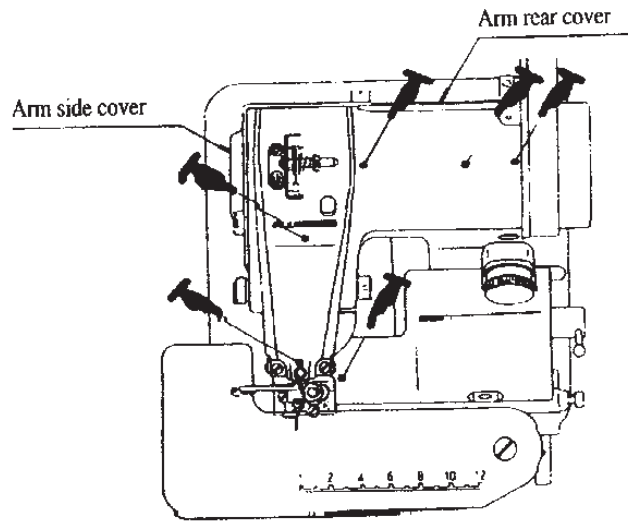

FIG.7

3. NEEDLE AND THREAD

Select the needle (LW × 6T)

To ensure the good operation, the thread and terial should be selected as follows:

Needle	Thread	Sewing material
Size 3(11)	No.80-100	Nylon silk or other thin materials
Size 3 1/2(14)	No.60-70	Cotton, woolen or other medium material
Size 4(16)	No.50-60	Thick woolen or other thick material

4. REPLACING NEEDLE (FIG.8)

Raise needle to its highest position by turning the wheel clockwise and loosen the needle clamp set screw (1) about two round, then replace the needle and insert the new needle into the needle carrier (2) and push it up as far as it will go. Install the needle clamp and tighten the needle clamp set screw. (Please refer to Fig.8)

FIG.8

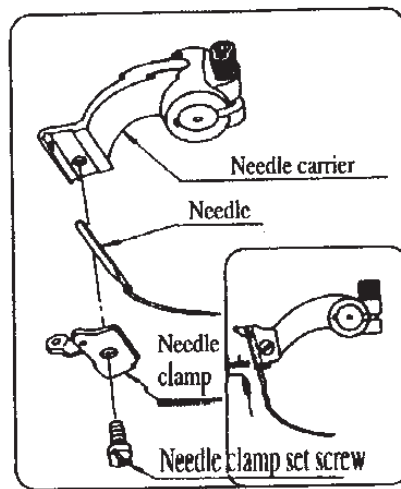

5. THREAD THE MACHINE (FIG.9-12)

A. Put the thread on the plastic cap (Fig.9)

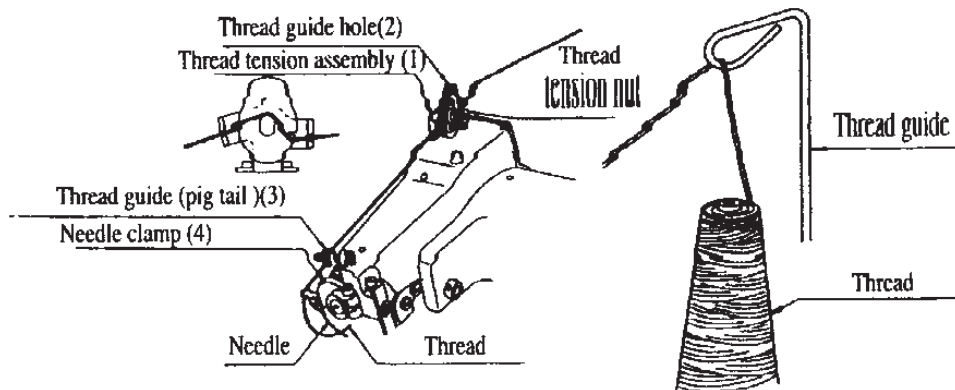

FIG.9

B. Using common thread spool ,please take off the plastic cap and put the thread spool on the thread stand. (Fig.10)

C. Please carefully refer to Fig.9 to thread the machine correctly.

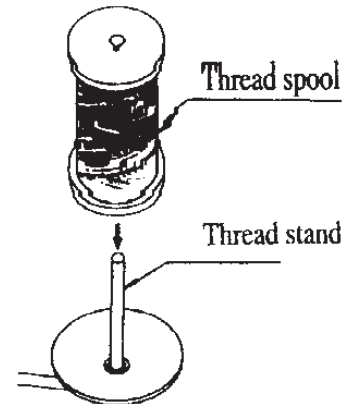

FIG.10

When the thread is up to the thread guide assembly (1), draw the thread through thread guide hole (2) out of the front hole (Fig.9), thread guide (3) and the hole of the needle clamp (4) from up to down. Please note that the direction of the needle is over left, draw the thread upward through out of the needle hole (Fig.11).

If loosen the work plate set screw and open the work plate, it is easier to thread the needle. (Fig.12)

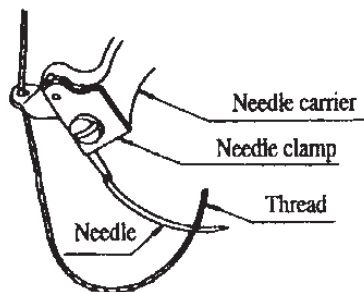

FIG.11

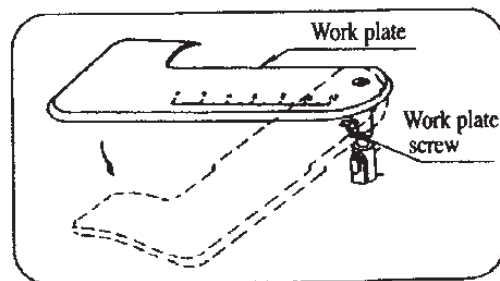

FIG.12

6. BEFORE OPERATION (FIG.13-14)

You should press the knee press rod to cause the clearance between the presser foot and the cylinder bed, and then make the sewing material flat put in the gap of needle plate presser plate or let the edge of the sewing material and the edge of the edge guide parallel.

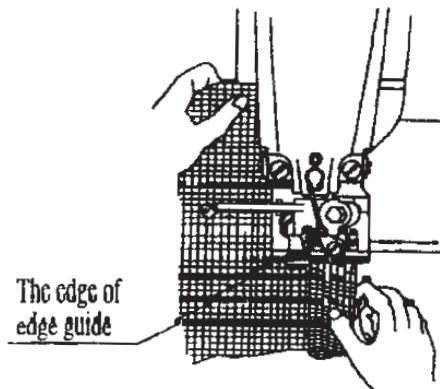

FIG.13

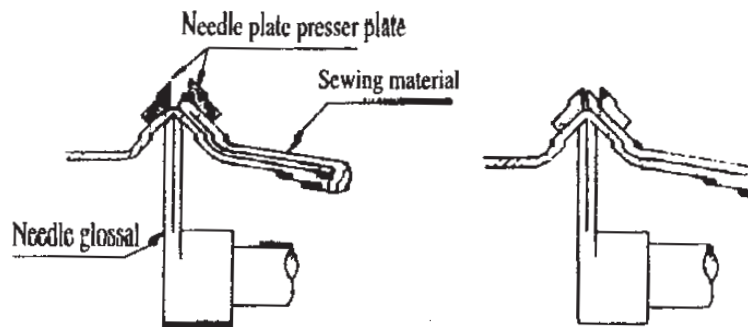

FIG.14-1

FIG.14-2

Loosen the knee press rod after putting down the sewing material and begin to operate slowly. Not only look at the needle, but also pay more attention to whether the sewing material is parallel to the edge of the edge guide or not.

A. Sewing edge of double-level material, put down the sewing material as Fig.14-1 showed.

B. Sewing edge of single-level material, put down the sewing material as Fig.14-2 showed.

7. ADJUSTING THE THREAD TENSION (FIG.15-16)

You should select the different thread according to the different sewing material. The thread tension can be adjusted by turning the thread tension nut on the moving arm.

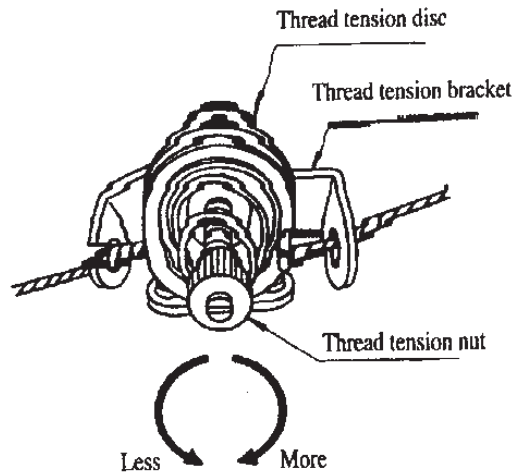

FIG.16

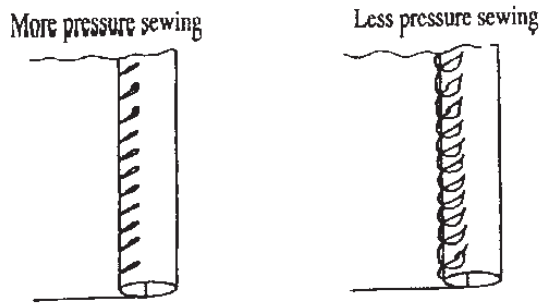
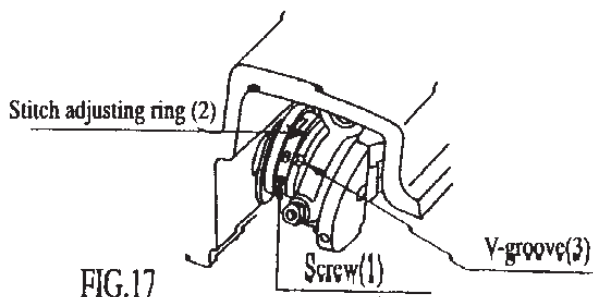

FIG.15

Turning the nut clockwise to increase pressure, Turning the nut counter-clockwise to decrease pressure. To avoid moving over 1/4 round in loosening or tightening every time, If need, you can test the pressure at first and adjust it again.

8. PRESETTING THE STITCH LENGTH (FIG.17)

Loosen the two nuts and open the arm side cover, then loosen the two nuts (1) in the stitch adjusting ring (2); Turn the stitch adjusting ring (2) until the V-groove aims at the number as you required, and then tighten the screws (1). The presetting number of our factory is "6"



The number of the stitch adjusting ring is on behalf of the stitch length showed as follows:

Number	4	5	6	7	8
Stitch length (M/M)	4	5	6	7	8

For getting suitable stitch, we suggest that you should operate in advance after selecting different material.

9. TO ADJUST THE STITCH DEPTH (FIG.18)

You can adjust the stitch depth needle by turning disc regulator in the front of the machine

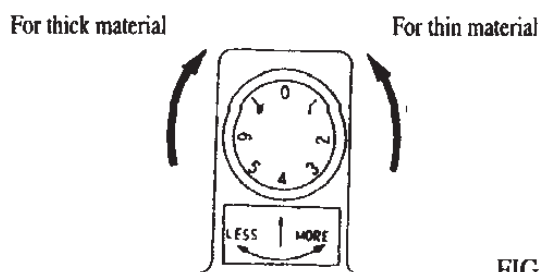

When you are sewing the thin material, please turn the disc regulator counter-clockwise to increase the stitch depth. The number on the disc is bigger, the depth of stitch is deeper. On the contrary, turn the disc regulator clockwise to decrease the stitch depth.

To avoid the needle and machine being broken, we suggest that you had better try to sew in a short length before operation and decide the suitable depth according to the actual stitch.

Note :Adjust the disc regulator until the machine stop.

10. TAKING THE SEWING MATERIAL OUT (FIG.19)

You can stop the machine and turn the pulley clockwise until the needle separated from the fabric (the needle is up to the highest position). And then, you can press the knee press rod to right and draw the fabric out of the rear of the machine that can lock the end clearance and broke the thread.

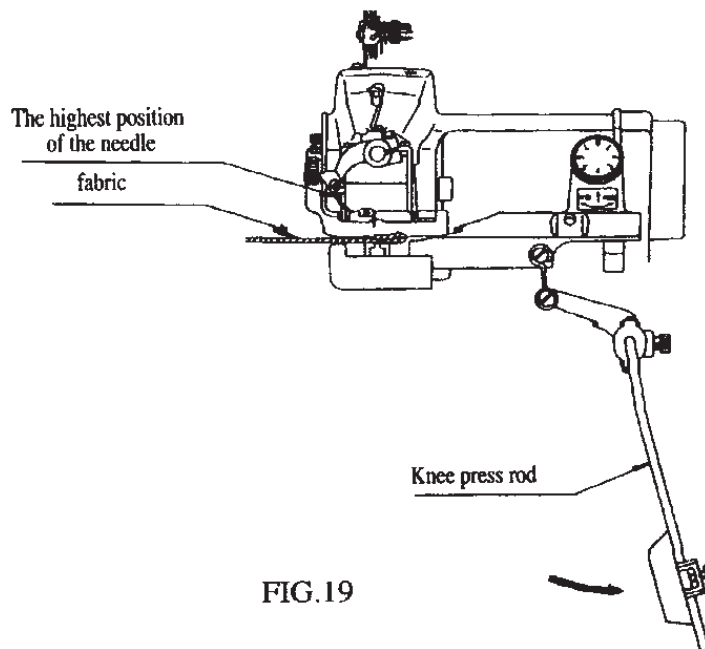

FIG.19

11. SKIP STITCH DEVICE (FIG.20-21)

The adjusting lever on the right side is the skip stitch device. When the skip lever is pointed to the "NO SKIP", it is the normal sewing that the needle threads the fabric each stitch. If the skip lever is point to the "SKIP", it is the skip sewing that the needle threads the fabric every other stitch.

To get good stitch, the skip lever should be preset until the machine stops. If you move the skip lever to the center, you will not guarantee the stitch effect. When you change the "SKIP" to "NO SKIP", you had better adjust the disc regulator again as your requirement.

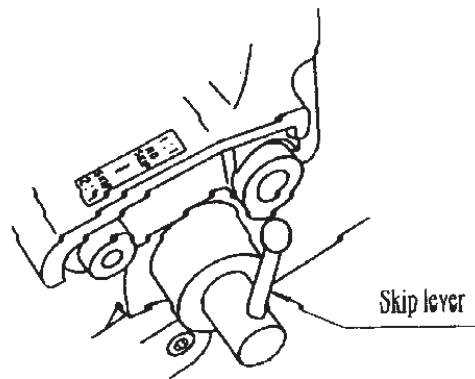

FIG.20

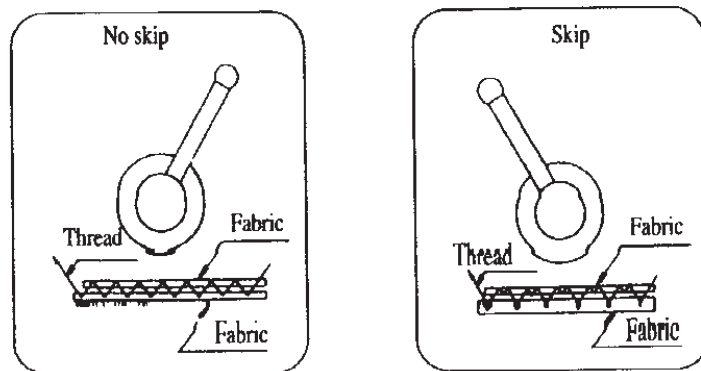
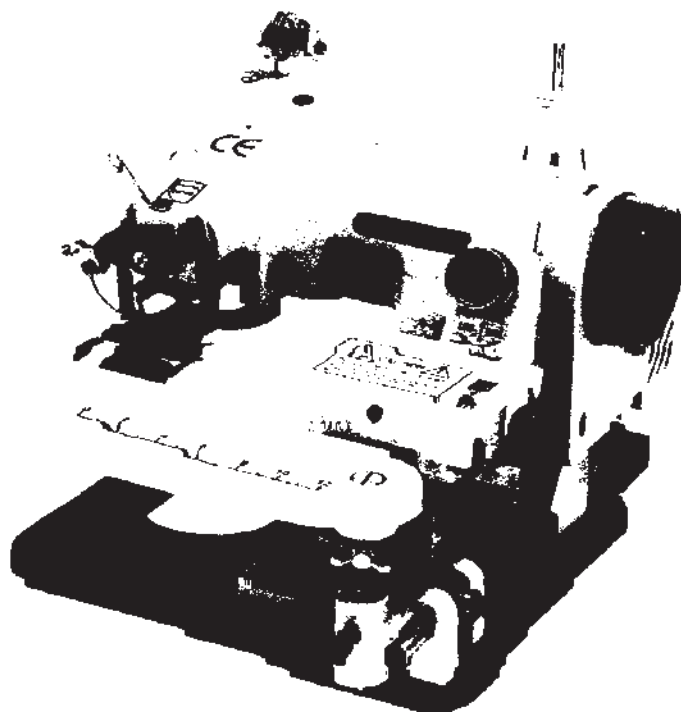

FIG.21

CM-500

TABLE BLINDSTITCH MACHINE

PARTS BOOK



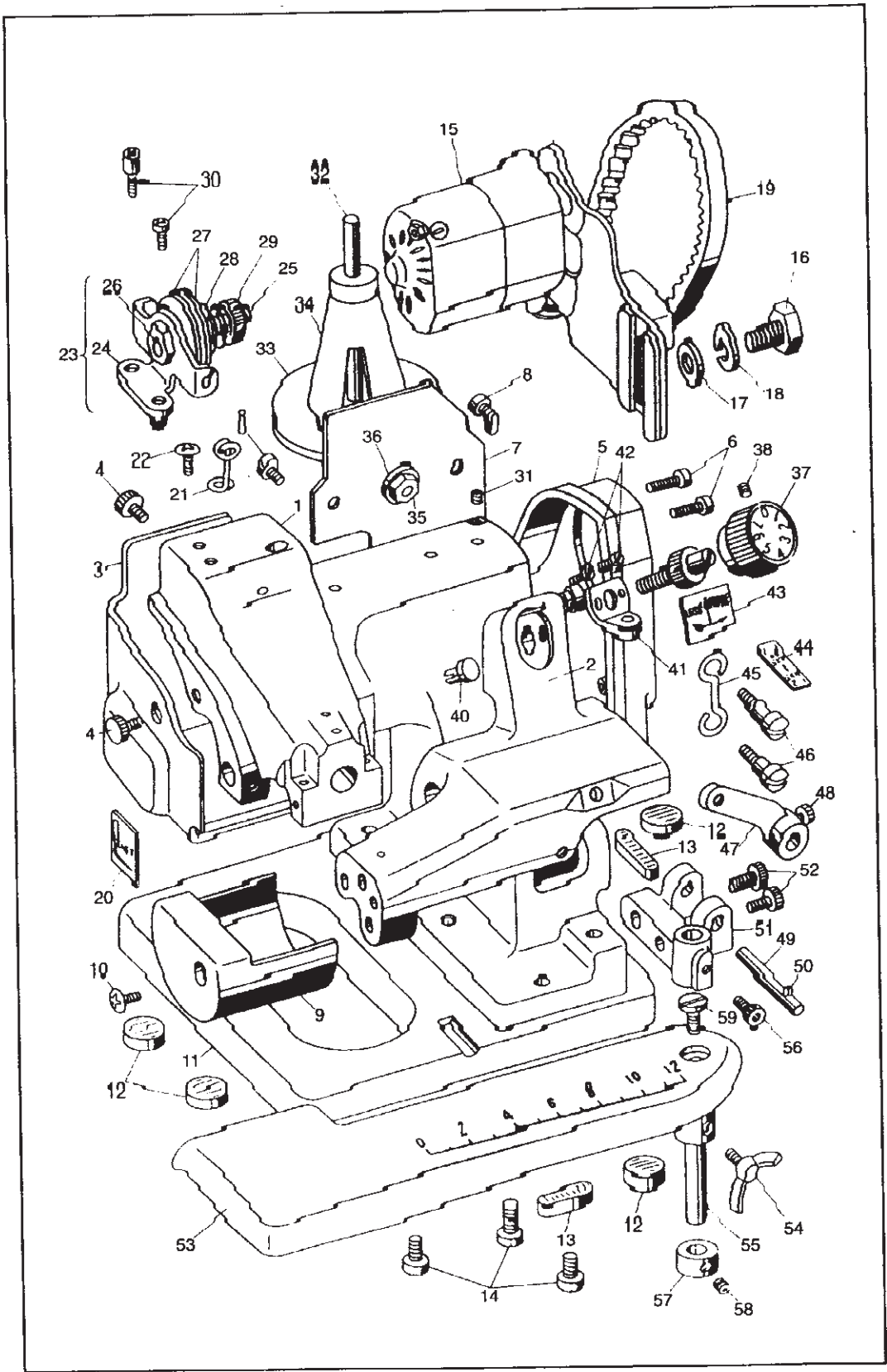

Ref. Nos.	Parts No.	Description
1	21001	Machine Frame
2	21002	Cylinder Bed
3	21003	Arm Side Cover
4	21004	Arm Side Cover Clamp Screw
5	21005	Pulley Cover
6	0144016	Pulley Cover Set Screw
7	21006	Arm Rear Cover
8	0144008	Arm Rear Cover Set Screw
9	21007	End Cover
10	0174008	End Cover Set Screw
11	S-21008-G	Machine Base with Rubber Cushion (Moss Green)
11	S-21008-R	Machine Base with Rubber Cushion (Wine-Red)
12	21009	Rubber Cushion (A)
13	21010	Rubber Cushion(B)
14	0186016	Machine Base Clamp Screw
15	10109-A	Motor
16	B-005	Motor Bracket Set Screw
17	B-006	Motor Bracket Spring Washer
18	B-007	Motor Bracket Spring washer
19	21001	Motor Belt
20	10131	Needle System Label (1.W x 6T)
21	4135	Thread Guide(Pig Tail)
22	0144008	Thread Guide Set Screw
23	S-21095	Thread Tension Assembly (Ref. Nos. 24-29)
24	21095	Thread Tension Bracket
25	21096	Thread Tension Post
26	4070	Thread Tension Post Nut
27	5190-A	Thread Tension Disc
28	79-B	Thread Tension Spring
29	83	Thread Tension Nut
30	0144008	Thread Tension Bracket Set Screw
31	0046006	Thread Guide Stud Set Screw
32	21093	Thread Stand
33	21094	Thread Stand Base
34	AC-101	Plastic Cap
35	11145	Thread Stand Nut
36	{054}	Thread Stand Washer
37	S-10513-G	Disc Regulator (Moss-Green)
37	S-10513-R	Disc Regulator (Wine-Red)
38	6074	Disc Regulator Set Screw
39	10514	Disc Regulating Dial Screw
40	10516	Disc Regulating Dial Screw Prop
41	10515-A	Disc Regulating Plate Spring
42	8339	Disc Regulating Plate Spring Set Screw
43	21068	Disc Regulator Indicating Label
44	21037	Skip Stitch Label
45	10076-A	Cylinder Bed Connecting Hook
46	21085	Cylinder Bed Connecting Hook Screw
47	21083	Knee Lifter Crank
48	0216016	Knee Lifter Crank Set Screw
49	21084	Knee Lifter Shaft
50	10074	Knee Lifter Shaft Spring Pin
51	21082	Work Plate Bracket
52	0216016	Work Plate Bracket Set Screw
53	21081	Work Plate
54	10085	Work Plate Wing Screw
55	10082	Work Plate Shaft
56	0216012	Work Plate Shaft Set Screw
57	21023	Work Plate Shaft Collar
58	0096006	Work Plate Shaft Collar Set Screw
59	10083	Work Plate Screwed Cap

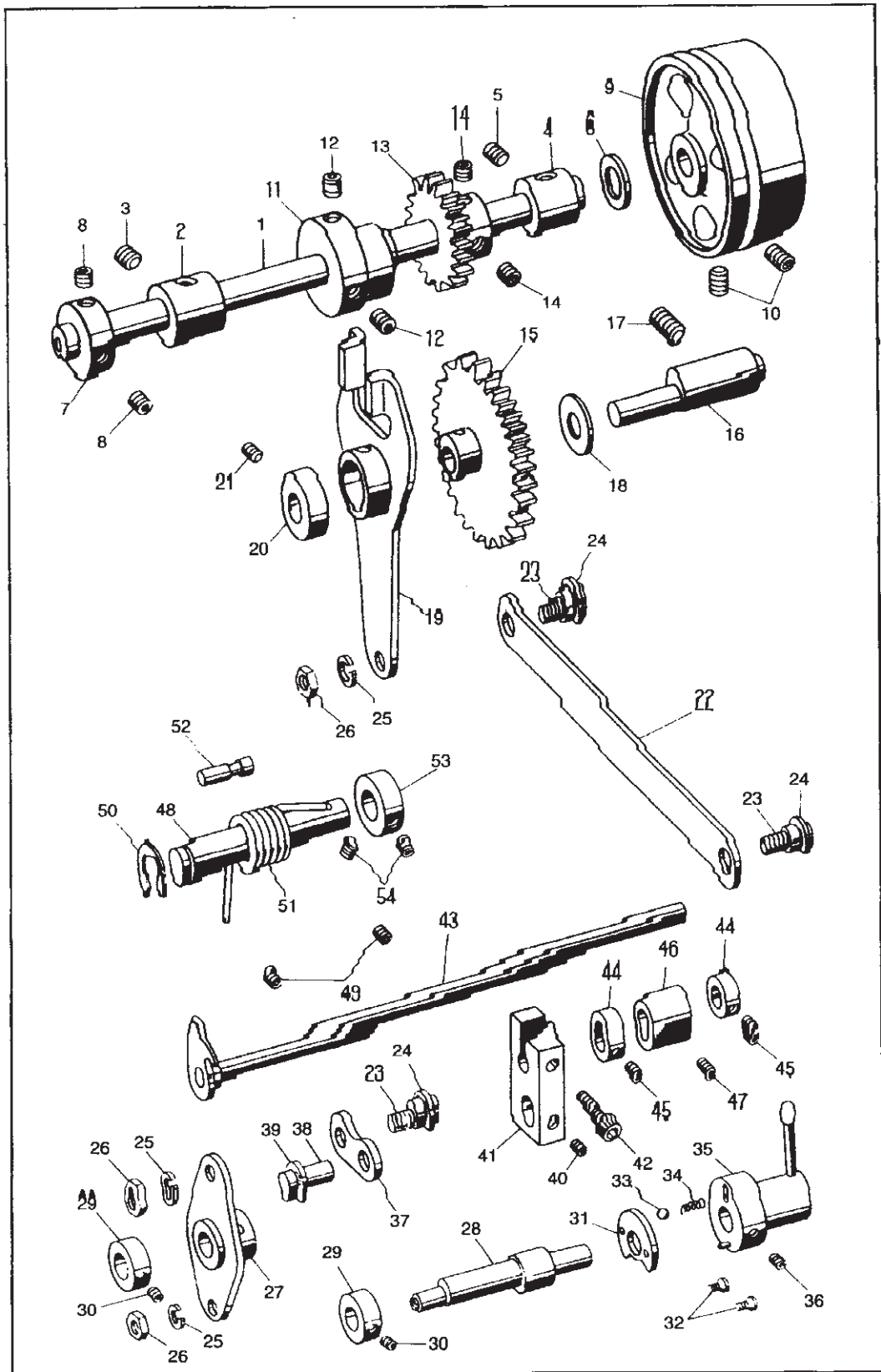

Ref. Nos.	Parts No.	Description
1	21012	Main Shaft
2	21013	Main Shaft Bushing (Front)
3	0096010	Main Shaft Bushing Set Screw
4	21014	Main Shaft Bushing (Rear)
5	0096010	Main Shaft Bushing Set Screw
6	21015	Main Shaft Thrust Washer
7	21016	Main Shaft Collar
8	0096006	Main Shaft Collar Set Screw
9	21017 -G	Pulley (Moss-Green)
9	21017-R	Pulley (Wine-Red)
10	0096014	Pulley Set Screw
11	21018	Eccentric Bushing
12	0096008	Eccentric Bushing Set Screw
13	21019	Main Shaft Gear (Small)
14	0096006	Main Shaft Gear Set Screw
15	21020	Skip Stitch Gear (Large)
16	21021	Skip Stitch Gear Eccentric Shaft
17	0096010	Skip Stitch Gear Eccentric Shaft Set Screw
18	21015	Skip Stitch Gear Eccentric Shaft Thrust Washer
19	21022	Skip Stitch Gear Eccentric Shaft Fork
20	21023	Skip Stitch Gear Eccentric Shaft Collar
21	0096006	Skip Stitch Gear Eccentric Shaft Collar Set Screw
22	21024	Connecting Link (Long)
23	21025	Connecting Link /Rod Holding Screw
24	10060	Connecting Link /Rod Holding Screw Snap Ring
25	10627	Connecting Link/Rod Holding Screw Spring Washer
26	17202	Connecting Link/Rod Holding Screw Nut
27	21026	Connecting Rod
28	21027	Skip Stitch Eccentric Shaft
29	21023	Skip Stitch Eccentric Shaft Collar
30	0096006	Skip Stitch Eccentric Shaft Collar Set Screw
31	21028	Skip Stitch Lever Plate
32	0124008	Skip Stitch Lever Plate Set Screw
33	4010	Skip Stitch Lever Plate Ball
34	10052	Skip Stitch Lever Plate Spring
35	S-21029	Skip Stitch Lever
36	0096010	Skip Stitch Lever Set Screw
37	21031	Connecting Link (Short)
38	21032	Connecting Link Holding Pin
39	10060	Connecting Link Holding Pin Snap Ring
40	0094004	Connecting Link Holding Pin Set Screw
41	21033	Connecting Block
42	0214012	Connecting Block Set Screw
43	S-21034	Ridge Forming Disc Shaft Assembly
44	21036	Ridge Forming Disc Shaft Collar
45	0094004	Ridge Forming Disc Shaft Collar Set Screw
46	10517	Ridge Forming Disc Shaft Bushing
47	0094006	Ridge Forming Disc Shaft Bushing Set Screw
48	21069	Cylinder Bed Shaft
49	0096006	Cylinder Bed Shaft Set Screw
50	19117	Cylinder Bed Shaft Snap Ring
51	21070	Cylinder Bed Shaft Spring
52	21071-A	Cylinder Bed Shaft Spring Pin
53	21016	Cylinder Bed Shaft Collar
54	0096006	Cylinder Bed Shaft Collar Set Screw

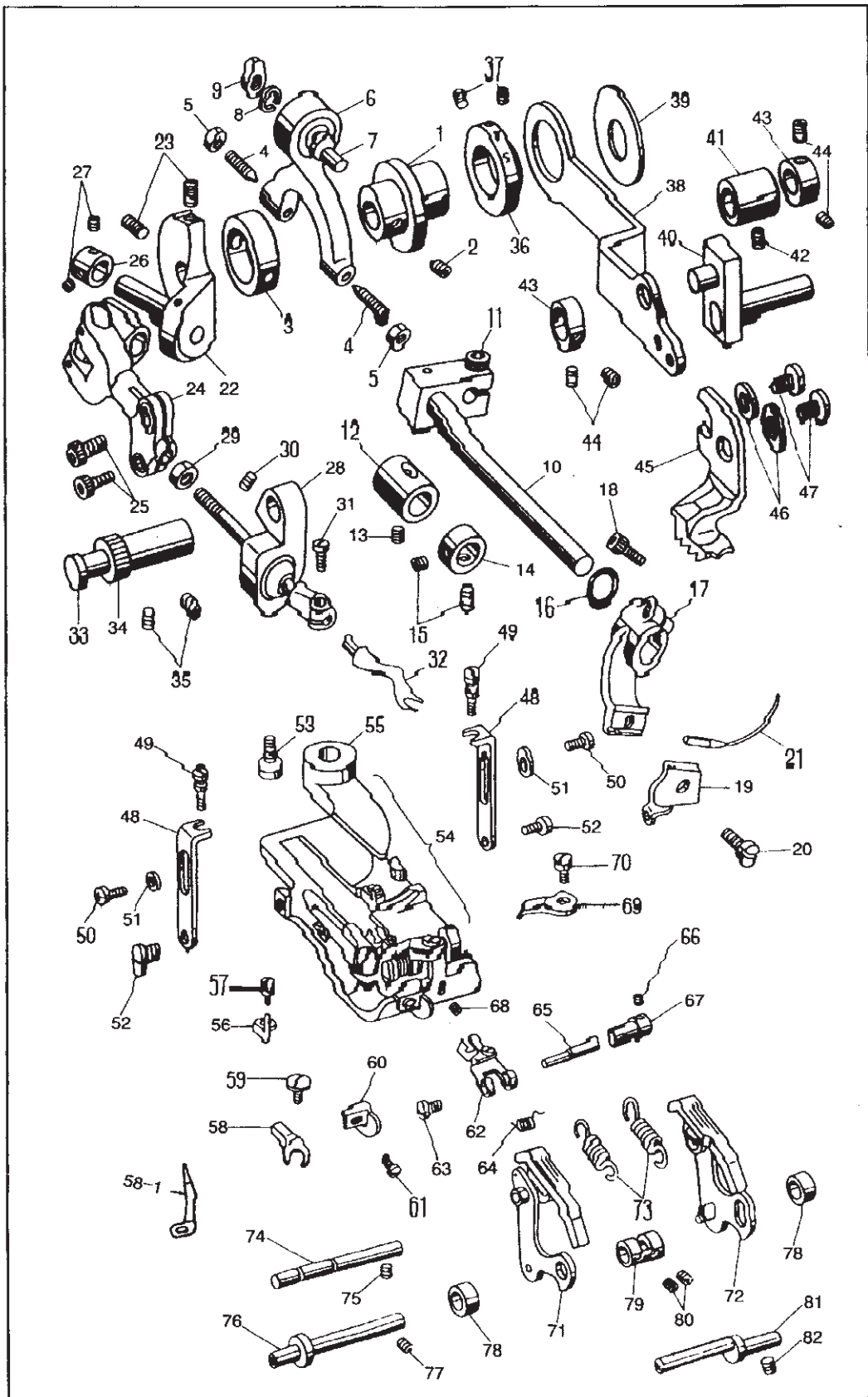

Ref. Nos.	Parts No.	Description	
1	21038	Eccentric Bushing	
2	0085010	Eccentric Bushing Set Screw	
3	21046	Needle Yoke Ring	
4	21047	Needle Yoke Center Screw	
5	21048	Needle Yoke Center Screw Nut	
6	S-21049-A	Needle Yoke & Ball Joint	
7	21052-B	Needle Yoke & Eccentric Pin	
8	8179	Needle Yoke Eccentric Pin Spring Washer	
9	C-10027	Needle Yoke Eccentric Pin Nut	
10	S-21053	Needle Carrier Shaft Crank	
11	0214016	Needle Carrier Shaft Crank Set Screw	
12	21005	Needle Carrier Shaft Bushing	
13	0094006	Needle Carrier Shaft Bushing Set Screw	
14	21016	Needle Carrier Shaft Collar	
15	0096006	Needle Carrier Shaft Collar Set Screw	
16	19034	Needle Carrier Shaft "O" Ring	
17	21056	Needle Carrier	
18	0215016	Needle Carrier Clamp Screw	} For Needle System LW x 6T (Re: LW x 5T, refer to page 4.)
19	4025-A	Needle Clamp	
20	121	Needle Clamp Set Screw	
21	4181	Needle (LW x 6T)	
22	S-21057	Looper Drive Crank & Pin	
23	0096014	Looper Drive Crank Set Screw	
24	S-21059	Looper Yoke with Joint & Pin	
25	0214012	Looper Yoke Set Screw	
26	17037	Looper Yoke Pin Collar	
27	17146	Looper Yoke Pin Collar Set Screw	
28	S-21062-A	Looper Carrier Assembly	
29	21048	Looper Carrier Nut	
30	0096006	Looper Ball Joint Clamp Screw	
31	4640	Looper Clamp Screw	
32	4039	LOOPER	
33	21064	Looper Ball Joint Pin	
34	21065	Looper Ball Joint Eccentric Sleeve	
35	0046008	Looper Ball Joint Eccentric Sleeve Set Screw	
36	21039-A	Stitch Regulating Eccentric	
37	0094006	Stitch Regulating Eccentric Set Screw	
38	21040	Feed Lever	
39	21041	Feed Lever Thrust Washer	
40	S-21042-A	Feed Lever Crank	
41	10517	Feed Lever Crank Bushing	
42	0094006	Feed Lever Crank Bushing Set Screw	
43	21045	Feed Lever Crank Collar	
44	0094004	Feed Lever Crank Collar Set Screw	
45	4047-C	Feed Dog	
46	2528	Feed Dog washer	
47	4048-A	Feed Dog Set Screw	
48	4061-A	Presser Foot Bracket	
49	21066	Presser Foot Bracket Adjusting Screw	
50	0144008	Presser Foot Bracket Holding Screw	
51	11158	Presser Foot Bracket Holding Screw Washer	
52	4186	Presser Foot Holding Screw	
53	21067	Presser Foot Clamp Screw	
54	PF100	Presser Foot Assembly (Ref.Nos.54-69)	

Ref. Nos.	Part No.	Description
55	4049 -B	Plain Presser Foot
56	4048-A	Chaining Finger
57	4185	Chaining Finger Set Screw
58	11563	Needle Guide 58-1-11563-A Stitch Stabilizing Guide
59	4052-A	Needle Guide Set Screw
60	4059	Edge Guide
61	4185	Edge Guide Set Screw
62	4055-ÇAS	Cloth Retainer
63	4185	Cloth Retainer Screw
64	4056	Cloth Retainer Spring
65	4054	Cloth Retainer Eccentric Stud
66	4183	Cloth Retainer Eccentric Set Screw
67	4053	Cloth Retainer Eccentric Stud Bushing
68	130-B	Cloth Retainer Eccentric Stud Bushing Set Screw
69	4057-B	Cloth Retainer Stopper
70	4182	Cloth Retainer Stopper Set Screw
71	S-21072	Feed Plate Assembly(Left)
72	S-21073	Feed Plate Assembly(Right)
73	21078	Feed Plate Bracket Spring
74	21079	Feed Plate Bracket Spring Pin
75	0094006	Feed Plate Bracket Spring Pin Set Screw
76	21075	Feed Plate Bracket Shaft
77	0094006	Feed Plate Bracket Shaft Set Screw
78	21076	Feed Plate Bracket Shaft Spacer
79	21077	Feed Plate Bracket Shaft Thrust Collar
80	0094004	Feed Plate Bracket Shaft Thrust Collar Set Screw
81	21080	Feed Plate Bracket Eccentric Shaft
82	0094006	Feed Plate Bracket Eccentric Shaft Set Screw